

**ORDINANCE NO. 580**

**AN ORDINANCE OF THE CITY COUNCIL OF THE CITY OF SANTEE, CALIFORNIA  
ADDING CHAPTER 13.20 "SPECIFIC PLAN DISTRICT" TO TITLE 13 AND  
AMENDING CHAPTER 13.04 "ADMINISTRATION" OF THE SANTEE MUNICIPAL  
CODE, AND APPROVING THE FANITA RANCH SPECIFIC PLAN  
(CASE FILES R2017-1 AND SP2017-1)**

**APN'S: 374-030-02; 374-050-02; 374-060-01; 376-010-06; 376-020-03; 376-030-01; 378-020-46, 50, 54; 378-030-08; 378-210-01; 378-210-03, 04; 378-210-10, 11; 378-220-01; 378-381-49; 378-382-58; 378-391-59; 378-392-61, 62; 380-031-18; 380-040-43, 44**

**(RELATED TO PROJECT NUMBERS: GPA2017-2,  
TM2017-3, P2017-5, P2020-2, DR2017-4, AEIS2017-11)**

**APPLICANT: HOMEFED FANITA RANCHO LLC**

**WHEREAS**, California Government Code Section 65450 authorizes cities to prepare and adopt specific plans for the systematic implementation of the general plan for all or part of the area covered by the general plan; and

**WHEREAS**, on September 23, 2020, the City Council adopted Resolution No. 094-2020 approving a General Plan Amendment (GPA) to change the land use designations for the Fanita Ranch property from PD – Planned Development, R –1 – Low Density Residential, and HL – Hillside/Limited Residential to SP – Specific Plan; and

**WHEREAS**, the Santee Municipal Code currently does not include "Specific Plan (SP)" as a zoning district; and

**WHEREAS**, the amendment to Chapter 13.04 will add a Specific Plan (SP) base zone to the list of zoning districts in the City; and

**WHEREAS**, the addition of Chapter 13.20, "Specific Plan District," is necessary to reflect the Specific Plan (SP) zone district in the zoning regulations; and

**WHEREAS**, the Specific Plan District is included in the zoning regulations to establish the process for the preparation, adoption and amendment of a specific plan; and

**WHEREAS**, the Fanita Ranch Specific Plan implements the goals, policies and objectives of the Santee General Plan; and

**WHEREAS**, pursuant to California Public Utilities Code section 21670, notice of HomeFed Fanita Rancho LLC's Fanita Ranch project ("Project") application was provided to the San Diego County Regional Airport Authority ("Authority"); Authority correspondence dated November 14, 2018, confirmed that the Project site lies outside of the Airport Influence Area of the adopted Airport Land Use Compatibility Plan (ALUCP) for Gillespie Field and poses no conflict with the ALUCP; and

## ORDINANCE NO. 580

**WHEREAS**, the City Council has certified the Final Revised Environmental Impact Report (EIR) pursuant to the California Environmental Quality Act and adopted Findings of Fact, a Statement of Overriding Considerations and a Mitigation Monitoring and Reporting Program for the Fanita Ranch project. The City Council hereby incorporates by reference, as if fully set forth herein, Resolution 093-2020 certifying the Final Revised EIR and adopting the Findings of Fact, and Statement of Overriding Considerations and Mitigation Monitoring and Reporting Program for the Fanita Ranch project.

**NOW THEREFORE**, the City Council of the City of Santee hereby ordains as follows:

**Section 1.** The City Council finds in its independent judgment that the proposed amendment to the Santee Municipal Code has been fully analyzed in the Final Revised EIR.

**Section 2.** The City Council finds, in accordance with Santee Municipal Code Section 13.04.050, that the addition of a new zone district is consistent with the Santee General Plan and Title 13 "Zoning" because it:

- A. Provides a tool for the development of more defined land use, development standards, infrastructure, and design guidelines within specific plan areas, and
- B. Furthers the implementation of the goals, objectives and policies of the Santee General Plan.

**Section 3.** Chapter 13.04 "Administration" is hereby amended and Chapter 13.20 "Specific Plan District" is hereby added to Title 13 of the Santee Municipal Code, to read as set forth in **Exhibit A**.

**Section 4.** The Santee Zone District Base Map, that is the City's official zoning map, is hereby amended to remove the Planned Development (PD), Low Density Residential (R-1), and Hillside/Limited Residential (HL) districts as depicted on **Exhibit B** and add the "SP - Specific Plan" District as depicted on **Exhibit C**.

**Section 5.** The City Council finds that the Fanita Ranch Specific Plan is in conformance with the goals, policies, and objectives of the General Plan and other adopted goals and policies of the City. The Fanita Ranch Specific Plan is hereby approved and adopted as depicted in **Exhibit D**.

**Section 6.** If any section, subsection, phrase, or clause of this ordinance is for any reason held to be invalid or unconstitutional by any court of competent jurisdiction, such decision shall not affect the validity of the remaining portions of this ordinance. The City Council hereby declares that it would have passed this ordinance and each section, subsection, phrase or clause thereof irrespective of the fact that any one or more sections, subsections, phrases, or clauses be declared unconstitutional.



**ORDINANCE NO. 580**

**Section 7.** This Ordinance shall become effective thirty (30) days after its adoption.

**Section 8.** The City Clerk is directed to publish notice of this Ordinance as required by law.

**INTRODUCED AND FIRST READ** at a Regular Meeting of the City Council of the City of Santee, California, on the 23<sup>rd</sup> day of September, 2020, and thereafter **ADOPTED** at Regular Meeting of said City Council held on the 14<sup>th</sup> day of October, 2020, by the following vote to wit:

**AYES: HALL, KOVAL, MCNELIS, MINTO**

**NOES: HOULAHAN**

**ABSENT: NONE**

**APPROVED:**

  
\_\_\_\_\_  
**JOHN W. MINTO, MAYOR**

**ATTEST:**

  
\_\_\_\_\_  
**ANNETTE ORTIZ, CMC, CITY CLERK**

- Exhibits      A:      Amendments to Title 13 – Zoning  
                  B:      Existing Zone District Map  
                  C:      Proposed Zone District Map  
                  D:      Fanita Ranch Specific Plan

**Exhibit A**  
**Amendments to Title 13 – “Zoning”**

Title 13 (“Zoning”) of the Santee Municipal Code is hereby amended to add a “Specific Plan District” to Section 13.04 (“Administration”) and Chapter 13.20 (“Specific Plan District”) as shown below:

**Chapter 13.04 (“Administration”)**

Section 13.04.020.A, titled “Zoning Districts”, is hereby amended to add the Specific Plan District, shown as underlined text below:

<b>Table Excerpt</b>	
<b>District Title</b>	
<b>Other Districts</b>	
Park/Open Space	P/OS
Town Center	TC
Residential Business	RB
Planned Development	PD
<u>Specific Plan</u>	<u>SP</u>

**Chapter 13.20 Specific Plan District**

Chapter 13.20 is hereby added to Title 13 to establish a “Specific Plan District”, as follows:

**Section 13.20.010 Purpose and Intent**

Purpose. This chapter establishes the process for the preparation, adoption, and amendment of a specific plan. The specific plan provides a tool for the development of more specific land use, infrastructure, and/or design or development standards for properties requiring special treatment or consideration. The specific plan is a policy and regulatory tool for implementation of the goals and policies of the Santee General Plan.

**Section 13.20.020 SP - Specific Plan District Applicability**

The provisions of this chapter shall apply to the preparation, review, and adoption of all specific plans prepared for all real property within the City. The standards of this chapter, and eligibility for a specific plan, shall only apply to projects composed of a minimum of five acres of contiguous property. Any project of less than five acres shall not be eligible for a specific plan.



**Section 13.20.030**                      **SP - Specific Plan District Designation**

The SP – Specific Plan District requires the preparation of a specific plan for future development of an area within the City. State law authorizes cities to prepare and adopt specific plans for the systematic implementation of the general plan for all or part of the area covered by the general plan (California Government Code Section 65450). This district is intended for select properties within the City where a variety of development opportunities may be viable and where the City wishes to encourage innovative and very high-quality development. Specific plans shall contain planning policies and regulations, and may combine zoning regulations, capital improvement programs, detailed development regulations, and other regulatory requirements into one document, which are designed to meet the unique needs of a specific area. Specific plans shall provide a fiscal assessment, identification of required public improvements, public improvement and development phasing, financing plans and a development agreement.

**Section 13.20.040**                      **General Provisions.**

- A. Applicant-Generated. The preparation of a specific plan, and concurrent zoning and / or general plan amendment(s), may be started by an applicant or property owner. The use of a specific plan is appropriate where site-specific regulation beyond the scope of this title would be beneficial based upon features or unique characteristics of the property, such as innovative development in the form of buildings, construction, design, or use combinations.
  
- B. General Plan Consistency. All uses shall be consistent with the intent of the Santee General Plan and this title. Any specific plan proposal shall include a statement of the relationship of the specific plan to the general plan.
  
- C. Regulating Document. A specific plan may either supplement or supersede land use regulations of this title, including all previously adopted ordinances, standards, and guidelines. Upon adoption of a specific plan and requisite zoning / general plan amendments, the specific plan shall replace and take precedence over the zoning regulations of this title for the subject property. Where the regulations of a specific plan are silent, the zoning code regulations and all adopted ordinances, regulations, standards, and guidelines of the City shall apply, as deemed appropriate by the Director of the Department of Development Services.
  
- D. Specific plans shall contain planning policies and regulations, and may combine zoning regulations and other regulatory requirements into one document. Specific plans shall provide a fiscal assessment, identification of required public improvements, public improvement and development phasing, financing plans and a development agreement.

**Section 13.20.050 Required Content.**

A specific plan shall provide regulations and design standards governing the minimum and maximum development parameters of all real property within the identified specific plan area. A specific plan shall include a statement of its relationship and consistency with the general plan, and compliance with Article 8 of Chapter 3 of the California Government Code, commencing with Section 65450, and as may be amended by the State. The city maintains full authority and discretion to determine how a specific plan will be prepared. At minimum, a specific plan shall address the following:

- A. Purpose. State the relationship to the goals and policies of the general plan.
- B. Setting. State the existing and regional setting to establish the conditions and reasons for the project.
- C. Proposed Land Uses. Establish the distribution, type, definitions of, and regulations for all proposed land uses.
- D. Development Standards. Establish all regulating policies, including all the following standards for all building types:
  - 1. Building height, setbacks, massing, and design standards;
  - 2. Lot area, width, and depth;
  - 3. Maximum number of dwelling units and the maximum residential density of the specific plan area and designated land uses consistent with the general plan;
  - 4. Usable open space provisions and requirements within the development;
  - 5. Off-street parking and loading facilities;
  - 6. Architectural and site planning design and development standards, which may include design themes or similar architectural treatments to control future construction of buildings on parcels covered by the adopted plan; and
  - 7. Signage requirements, if different from the standards of this title, to be addressed by a unique sign program codified in the specific plan.
- E. Site Planning. Establish a comprehensive map of all streets, open spaces, private and public property, and land uses for all affected properties, consistent with the intent of the general plan and this title.
  - 1. Provide site planning at the perimeter of the area boundaries for the mutual protection of the specific plan and the surrounding properties.
  - 2. Site orientation to use available solar, wind, and natural setting benefits of the site, and to retain natural features and amenities found on site.



3. Provide landscape architectural concept plans and standards, including project entries, streetscapes, fencing details, lighting, signage, and street furniture.
- F. Infrastructure. Identify the proposed distribution, extent, intensity, and location of major components of public and private circulation/transportation, drainage, energy, sewers, solid waste disposal, water, and other essential facilities proposed.
1. Include physical and fiscal plans for the construction, improvement, or extension of transportation facilities, public utilities, and all other public facilities/services required to serve the specific plan area.
  2. All public rights-of-way within or abutting the development shall remain within applicable City specifications unless authorized by the Director of Development Services.
  3. Include layout and design of private streets and alleys; such private facilities shall be privately owned and maintained without public cost and maintenance responsibility for their intended purpose.
  4. Consideration of other forms of access, such as pedestrian ways, paseos, courts, plazas, driveways, trails, or open public parking areas may be made at the time of specific plan consideration by the City.
- G. Maintenance. Provisions ensuring the continued maintenance of private property, grounds, and all common areas.
- H. Phasing. Development phasing for the full life of the project and anticipated schedule, including start date and completion of each construction phase.
- I. Text and Graphics. A textual document incorporating graphics, including an executive summary and any additional information identified by the Director as pertinent to conveying the development intent, standards, and outcomes of the specific plan.

**Section 13.20.060 Specific Plan Review Process.**

- A. A Specific Plan District shall be established upon application of a property owner, and subject to the following provisions:
1. Submission of a Specific Plan for approval by the City Council pursuant to this chapter.
  2. Determination by the City Council that the establishment of the District and approval of the Specific Plan shall:

- (i) Provide for the development of a comprehensively planned community within the District that is superior to development otherwise allowable under alternate regulations.
- (ii) Provide for development within the District in a manner consistent with the General Plan.
- (iii) Provide for the construction, improvement, or extension of transportation facilities, public utilities, and public services required by development with the District.
- (iv) Address any other subjects which in the judgment of the City are necessary or desirable for implementation of the General Plan.

### **Section 13.20.070 Environmental Review**

A specific plan, which qualifies as a project under the California Environmental Quality Act (CEQA), shall be subject to environmental review in accordance with CEQA and City of Santee environmental review application requirements.

### **Section 13.20.080 Public Hearings and Approval**

- A. Public Hearings. The specific plan process is considered a discretionary action. Public hearings shall be held consistent with the public hearing procedures and requirements of Santee Municipal Code Section 13.04.100.
- B. Approval. The specific plan shall be adopted by ordinance or resolution of the City Council, in compliance with state law (California Government Code Section 65453). The City Council's action to adopt a specific plan shall be accompanied by findings that the specific plan is in conformance with the goals, policies, and objectives of the general plan and other adopted goals and policies of the City.
- C. Incorporation Upon Approval. An application for a specific plan and official Zoning District Base Map amendment shall be subject to review and approval in the same manner as prescribed in Section 13.04.050, "Amendments". Upon specific plan approval, the Zoning District Base Map shall be updated by the letters "SP" followed by reference letters identifying each separate District. The specific plan as approved by the City Council shall be incorporated into this title upon approval.

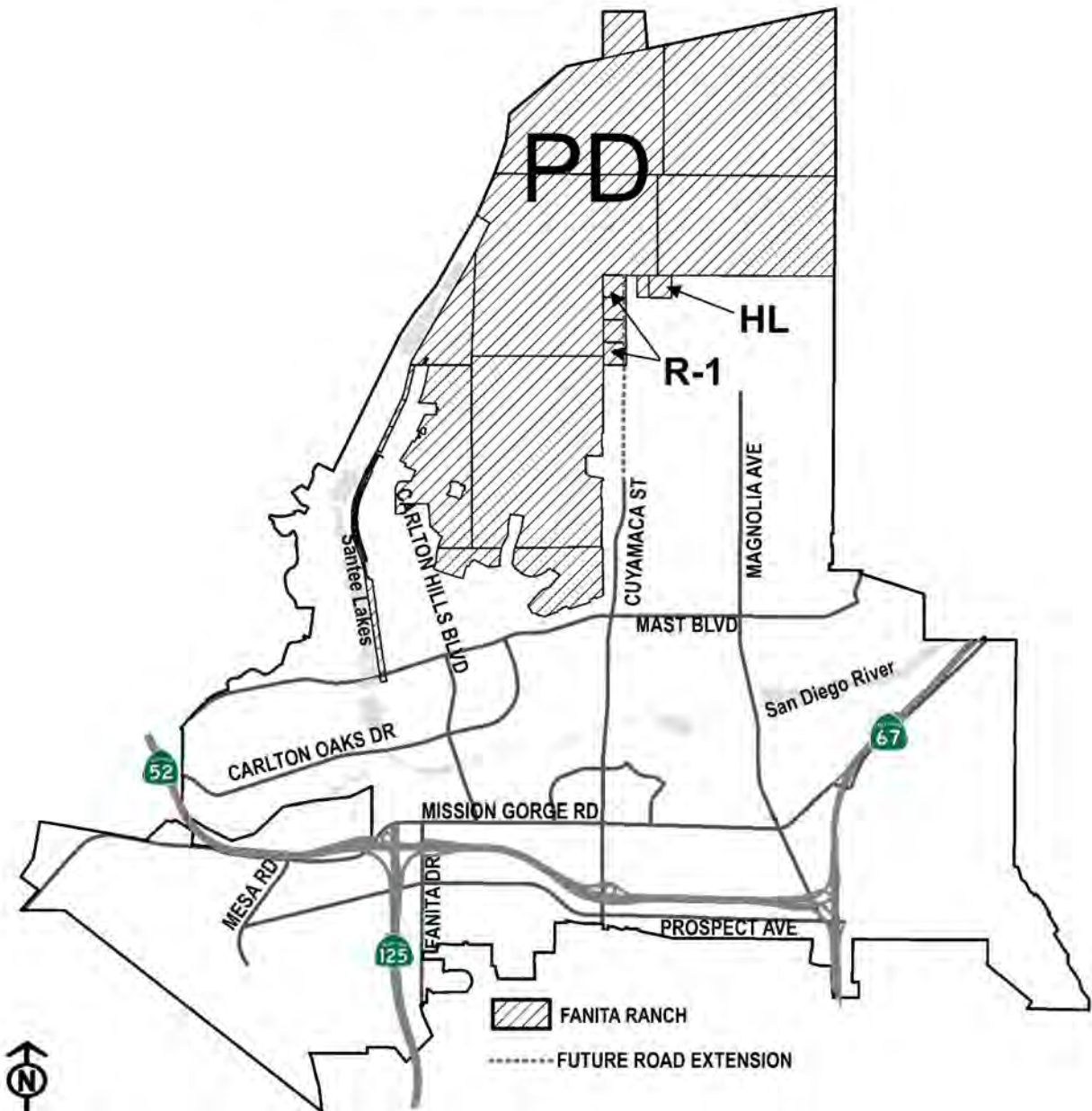


D. Specific Plan Fee. The City Council may impose a specific plan fee surcharge on development permits within the specific plan area, in compliance with state law (California Government Code Section 65456).

**Section 13.20.090**                      **Specific Plan Amendments**

A specific plan may be amended in the same manner as a zoning amendment, as provided by Section 13.04.050 for a change of district boundaries or for a change in the regulations applicable within a district.

## Exhibit B: Existing Zone District Map



**SMC Section 13.19.020 PD -- Planned Development**

The PD (Planned Development) district is included in the zoning regulations in order to implement the goals, objectives and land uses specified in the general plan for properties within the City where a variety of development opportunities may be viable and where the City wishes to encourage innovative and very high-quality development in a manner which may not be possible under standard land use designations and their corresponding zones.

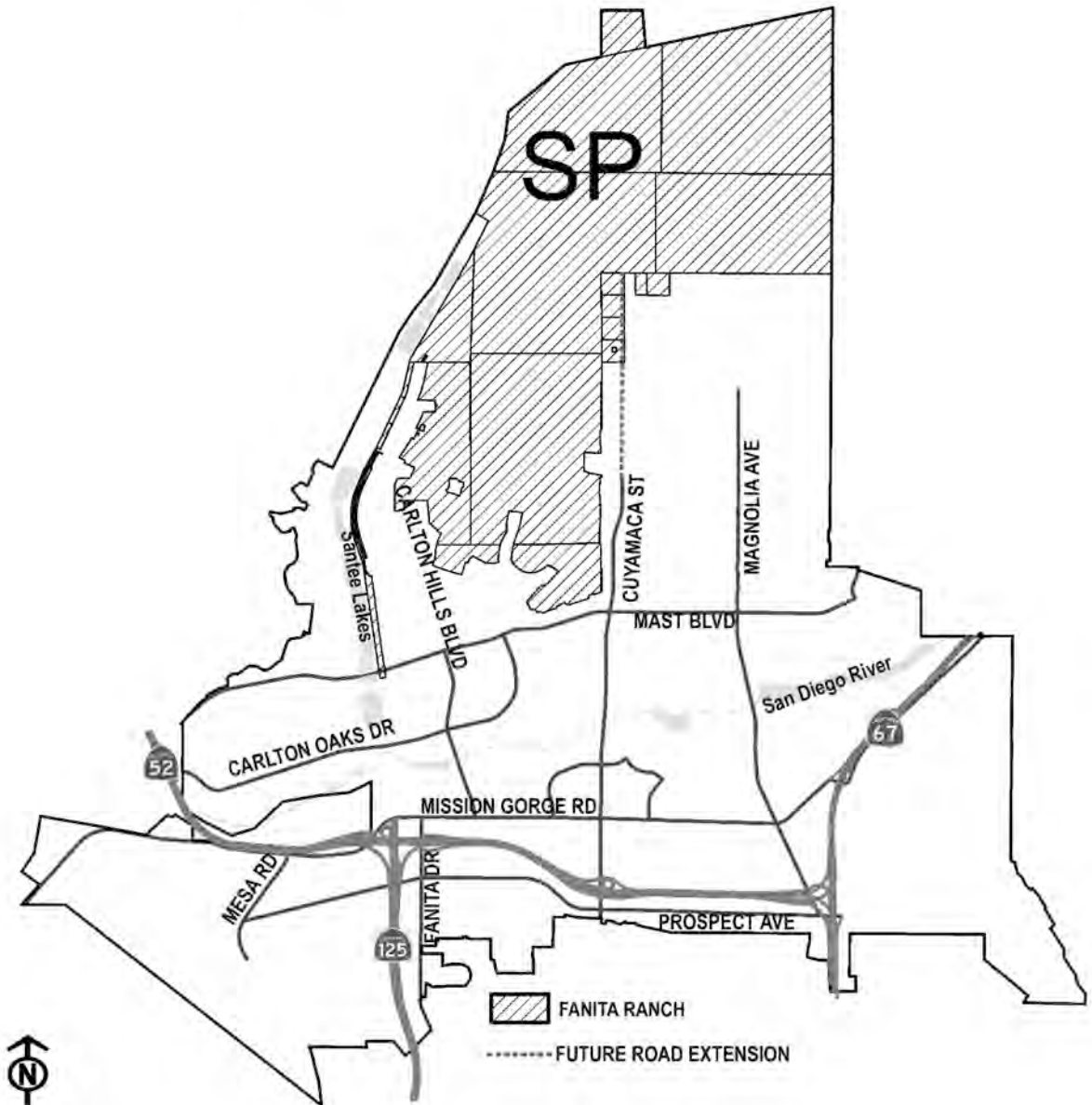
**SMC Section 13.10.020 HL -- Hillside/Limited Residential**

The HL (Hillside/Limited Residential) district is intended for residential development in areas that exhibit steep slopes, rugged topography and limited access. Residential uses are characterized by rural large estate lots with significant permanent open space area, consistent with the constraints of slope gradient, soil and geotechnical hazards, access, availability of public services and other environmental concerns.

**SMC Section 13.10.020 R-1 -- Low Density Residential**

The R-1 (Low Density Residential) district is intended for residential development characterized by single-family homes on one-half acre lots or larger which are responsive to the natural terrain and minimize grading requirements. The intent of this designation is to provide development of a semi-rural character through the use of varying setbacks and dwelling unit placement on individual parcels.

# Exhibit C: Proposed Zone District Map



SMC Section 13.20.030

SP -- Specific Plan

The SP – Specific Plan District requires the preparation of a specific plan for future development of an area within the City. State law authorizes cities to prepare and adopt specific plans for the systematic implementation of the general plan for all or part of the area covered by the general plan (California Government Code Section 65450). This district is intended for select properties within the City where a variety of development opportunities may be viable and where the City wishes to encourage innovative and very high-quality development. Specific plans shall contain planning policies and regulations, and may combine zoning regulations, capital improvement programs, detailed development regulations, and other regulatory requirements into one document, which are designed to meet the unique needs of a specific area. Specific plans shall provide a fiscal assessment, identification of required public improvements, public improvement and development phasing and financing plans and a development agreement.

# EXHIBIT D

# FANITA RANCH

## SPECIFIC PLAN



**CITY OF SANTEE**

MAY 2020



# **FANITA RANCH**

## **SPECIFIC PLAN**

*Prepared for:*

### **City of Santee**

10601 Magnolia Avenue

Santee, CA 92071

(619) 258-4100

Contact: Melanie Kush/Marni Borg

*Applicant:*

### **HomeFed Fanita Rancho LLC**

1903 Wright Place, Suite 220

Carlsbad, CA 92008

(760) 918-8200

Contact: Jeff O'Connor/Tom Blessent





# Table of Contents

## Table of Contents

### Chapter I: Introduction

- 1.1 Project Location and Regional Context.....1-1
- 1.2 Regulatory Context .....1-3
  - 1.2.1 Specific Plan Authority .....1-3
  - 1.2.2 Specific Plan Purpose .....1-3
  - 1.2.3 Relationship to the Santee General Plan.....1-4
  - 1.2.4 Relationship to the Santee Zoning Ordinance.....1-8
  - 1.2.5 Airport Compatibility .....1-8
  - 1.2.6 Relationship to Other City Documents .....1-9
  - 1.2.7 Legal Significance and CEQA .....1-9
- 1.3 Document Organization.....1-9
  - 1.3.1 Specific Plan Organization .....1-9
  - 1.3.2 Technical Studies and Supporting Documents..... 1-10
- 1.4 Development Approvals ..... 1-12

### Chapter 2: Community Vision

- 2.1 Fanita Ranch History .....2-1
- 2.2 Specific Plan Objectives.....2-2
  - 2.2.1 Land Use Planning and Community Design Objectives.....2-2
  - 2.2.2 Mobility Objectives.....2-3
  - 2.2.3 Recreation and Open Space Objectives .....2-3
  - 2.2.4 Resource Conservation Objectives.....2-3
  - 2.2.5 Economic Objectives.....2-4
- 2.3 Community Vision.....2-5

### Chapter 3: Land Use & Development Regulations

3.1	Land Use Plan .....	3-1
3.1.1	Land Use Plan Description .....	3-1
3.1.2	Site Utilization Plan .....	3-4
3.2	Land Use Designations and Development Regulations .....	3-11
3.2.1	Village Center (VC) .....	3-12
3.2.2	Medium Density Residential (MDR) .....	3-16
3.2.3	Low Density Residential (LDR) .....	3-20
3.2.4	Active Adult (AA) .....	3-24
3.2.5	School (S) Overlay .....	3-28
3.2.6	Parks (CP, NP and MP) .....	3-29
3.2.7	Open Space (OS) .....	3-31
3.2.8	Agriculture (A) Overlay .....	3-32
3.2.9	Special Use (SU) .....	3-36
3.2.10	Habitat Preserve (HP) .....	3-40
3.2.11	Regulations Applying to Multiple Land Use Designations .....	3-41
3.2.11.1	Projections, Encroachments and Height Exceptions .....	3-41
3.2.11.2	Accessory Dwelling Units .....	3-42
3.2.11.3	Accessory Uses and Structures .....	3-42
3.2.11.4	California Rooms .....	3-43
3.2.11.5	Reciprocal Use Easements .....	3-44
3.2.11.6	Equipment Screening .....	3-44
3.2.11.7	Trash Enclosures .....	3-45
3.2.11.8	Fencing, Walls and Landscaping .....	3-45
3.2.11.9	Parking .....	3-47
3.2.11.10	Performance Standards .....	3-51
3.2.11.11	Signage .....	3-52
3.2.11.12	Stormwater Low Impact Development Standards .....	3-53

## Chapter 4: Mobility

4.1	Mobility Plan.....	4-1
4.1.1	Regional Access.....	4-1
4.1.2	Complete Streets .....	4-1
4.1.3	Traffic Calming Plan.....	4-5
4.1.4	Bicycle Circulation.....	4-15
4.1.5	Pedestrian Circulation .....	4-17
4.1.6	Alternative Vehicles & Ride-sharing .....	4-24
4.1.7	Transit.....	4-26
4.2	Street Corridor & Landscape Standards.....	4-28
4.2.1	Fanita Parkway - 4-Lane Parkway/Major Arterial (Mast Boulevard to Lake Canyon Road) .....	4-30
4.2.2	Fanita Parkway - 3-Lane Parkway (Lake Canyon Road to Ganley Road).....	4-32
4.2.3	Fanita Parkway - 2-Lane Parkway Type II (Ganley Road to Street “E”).....	4-34
4.2.4	Fanita Parkway - 2-Lane Parkway Type III (Street “E” to Street “N”).....	4-36
4.2.5	Cuyamaca Street, Off-Site - 4-Lane Major Arterial (Mast Boulevard to Chaparral Drive).....	4-38
4.2.6	Cuyamaca Street, On & Off-Site - 2-Lane Parkway Type I (Chaparral Drive to Street “A”/Street “W”) .....	4-40
4.2.7	Cuyamaca Street - Residential Collector Type V (Street “A”/Street “W” to Street “T”) .....	4-42
4.2.8	Cuyamaca Street - Village Collector (Street “T” to Fanita Parkway).....	4-44
4.2.9	Magnolia Avenue, Off-Site - Collector Type IV (Existing Terminus to Cuyamaca Street).....	4-46
4.2.10	Residential Collector Type I (Fanita Parkway to Cuyamaca Street).....	4-48
4.2.11	Residential Collector Type II (Through Habitat Preserve - Streets “V” and “W”).	4-50
4.2.12	Residential Collector Type III .....	4-52
4.2.13	Residential Collector Type VII .....	4-54
4.2.14	Residential Street .....	4-56
4.2.15	Carlton Hills Boulevard (Private Street).....	4-58
4.2.16	Split Residential Street (One-Way).....	4-60
4.2.17	Private Residential Street .....	4-62
4.2.18	Village Streets .....	4-64
4.2.19	Private Residential Driveway .....	4-67
4.3	Trail Corridor & Landscape Standards.....	4-69

## **Chapter 5: Landscape Architecture, Community Design & Outdoor Lighting Design Plan**

5.1	Community Organization and Landscape Theme.....	5-1
5.2	Gateways.....	5-5
5.2.1	Cuyamaca Street Gateway.....	5-5
5.2.2	Fanita Parkway Gateway.....	5-7
5.3	Landmarks.....	5-9
5.4	Villages.....	5-9
5.4.1	Fanita Commons.....	5-11
5.4.2	Orchard Village.....	5-18
5.4.3	Vineyard Village.....	5-25
5.5	Community-Wide Street Landscape Palette.....	5-32
5.6	Brush Management/Fuel Modification.....	5-42
5.7	Habitat Restoration Program.....	5-42
5.8	Walls and Fencing.....	5-43
5.9	Conceptual Lighting Plan.....	5-47

## **Chapter 6: Architectural Design Guidelines**

6.1	Architectural Styles.....	6-1
6.2	Building Typologies.....	6-26
6.2.1	Single Family Detached Homes.....	6-28
6.2.2	Detached Cluster Homes.....	6-30
6.2.3	Attached/Semi-Detached Homes.....	6-34
6.2.4	Attached Buildings.....	6-39
6.2.5	Community Buildings.....	6-42
6.3	Building Design.....	6-43
6.3.1	Building Placement and Orientation.....	6-43
6.3.2	Form and Massing.....	6-45
6.3.3	Garage Placement and Parking Areas.....	6-46
6.3.4	Roof Considerations.....	6-47
6.3.5	Articulation and Details.....	6-49
6.3.6	Materials and Colors.....	6-52
6.3.7	Functional Elements.....	6-52
6.3.8	Loading, Service and Trash Storage Areas.....	6-53

## Chapter 7: Parks, Recreation & Open Space

7.1	Parks, Recreation and Open Space Objectives .....	7-1
7.2	Park Land Dedication .....	7-2
7.3	Park and Recreation Concepts.....	7-7
7.3.1	Community Park .....	7-7
7.3.2	Neighborhood Parks .....	7-12
7.3.3	Village Green .....	7-14
7.3.4	Mini-Parks .....	7-17
7.3.5	AgMeander .....	7-19
7.3.6	Linear Parks.....	7-22
7.3.7	Typical Vista Points and Trailheads.....	7-25
7.4	Other Recreation and Open Space Areas.....	7-27

## Chapter 8: Grading, Utilities & Services

8.1	Grading Plan .....	8-1
8.2	Drainage and Stormwater Management.....	8-5
8.3	Sewer .....	8-7
8.4	Water .....	8-9
8.4.1	Recycled Water/Advanced Treated Water .....	8-11
8.4.2	Water Conservation.....	8-12
8.5	Dry Utilities.....	8-12
8.6	Fire Protection .....	8-13
8.6.1	Fire Station.....	8-13
8.6.2	Fire Protection Plan.....	8-13
8.6.2.1	Fuel Modification Zones .....	8-14
8.6.2.2	Other Vegetation Management .....	8-15
8.6.2.3	Fuel Modification Maintenance and Compliance Inspection.....	8-16
8.6.3	Wildland Evacuation Plan .....	8-16
8.6.4	Construction Fire Protection Plan .....	8-17
8.7	Law Enforcement.....	8-17
8.8	Solid Waste and Recycling .....	8-17
8.8.1	Solid Waste and Recycling.....	8-17
8.8.2	Material Conservation and Waste Reduction .....	8-18
8.9	Education.....	8-19



## **Chapter 9: Open Space, Conservation & Sustainability**

9.1	Conservation Overview.....	9-1
9.2	Habitat Preserve.....	9-3
9.2.1	Habitat within Fanita Ranch .....	9-3
9.2.2	MSCP Subarea Plan.....	9-3
9.2.3	Fanita Ranch Preserve Management Plan.....	9-4
9.2.4	Preserve Management Objectives.....	9-4
9.2.5	Preserve Management Plan Strategies .....	9-5
9.3	Open Space.....	9-5
9.4	Cultural Resource Protection.....	9-6
9.5	Smart Growth and Sustainable Community.....	9-6
9.5.1	Open Space Conservation .....	9-7
9.5.2	Land Use, Transportation and Community Design.....	9-7
9.5.3	Energy, Atmosphere and Building System Performance.....	9-9
9.5.4	Water Conservation and Water Quality .....	9-10
9.5.5	Material Conservation, Recycling and Waste Reduction .....	9-11

## **Chapter 10: Implementation**

10.1	Introduction.....	10-1
10.2	Required Public Improvements.....	10-1
10.3	Phasing.....	10-2
10.4	Public Improvements Financing .....	10-4
10.4.1	Special Assessment Districts .....	10-4
10.4.2	Mello-Roos Community Facilities Act of 1982 .....	10-5
10.4.3	Business Improvement Districts.....	10-5
10.4.4	Community Service Districts.....	10-5
10.5	Operation and Maintenance .....	10-6
10.6	Administration and Implementation.....	10-8
10.6.1	Severability.....	10-8
10.6.2	Conflicts and Clarifications.....	10-8
10.6.3	Substantial Conformance .....	10-9
10.6.4	Subdivisions Standards and Procedures .....	10-10
10.6.5	Development Review .....	10-10
10.6.5.1	Applicability.....	10-10
10.6.5.2	Preliminary Review Procedures.....	10-10
10.6.5.3	Formal Development Review Procedures.....	10-11

10.7 Specific Plan Modifications and Amendments..... 10-13  
    10.7.1 Administrative Amendments (Minor Modifications) ..... 10-13  
    10.7.2 Formal Amendments ..... 10-16  
10.8 Monitoring and Updates ..... 10-16

**Appendix A: Definition of Terms**

**Appendix B: Fanita Ranch Street Design**

## List of Exhibits

Exhibit 1.1: Project Location and Context .....	1-2
Exhibit 2.1: Development Concept .....	2-6
Exhibit 3.1: Land Use Plan .....	3-2
Exhibit 3.2: Site Utilization Plan.....	3-5
Exhibit 3.3: Special Use Area Concept Plan.....	3-37
Exhibit 4.1: Circulation Plan.....	4-2
Exhibit 4.2: Conceptual Traffic Calming Plan .....	4-6
Exhibit 4.3.1: Conceptual Traffic Calming Gateway Design .....	4-9
Exhibit 4.3.2: Conceptual Roundabout Design .....	4-10
Exhibit 4.3.3: Conceptual Chicane Design .....	4-11
Exhibit 4.3.4: Conceptual Raised Crosswalk .....	4-12
Exhibit 4.3.5: Conceptual Intersection Pop-outs & On-Street Parking .....	4-13
Exhibit 4.3.6: Other Conceptual Traffic Calming Devices.....	4-14
Exhibit 4.4: Bicycle Circulation Plan .....	4-16
Exhibit 4.5: Pedestrian Circulation Plan .....	4-18
Exhibit 4.6: Enhanced Pedestrian Crossings .....	4-19
Exhibit 4.7: Southerly Bridge Crossing Detail.....	4-21
Exhibit 4.8: Regional Trail Context.....	4-22
Exhibit 4.9: Alternative Vehicle Circulation Plan .....	4-25
Exhibit 4.10: Conceptual Transit Plan .....	4-27
Exhibit 4.11: Planting Styles.....	4-29
Exhibit 4.12.1: Fanita Parkway - 4-Lane Parkway/Major Arterial.....	4-31
Exhibit 4.12.2: Fanita Parkway - 3-Lane Parkway .....	4-33
Exhibit 4.12.3: Fanita Parkway - 2-Lane Parkway Type II .....	4-35
Exhibit 4.12.4: Fanita Parkway - 2-Lane Parkway Type III.....	4-37
Exhibit 4.12.5: Cuyamaca Street, Off-Site - 4-Lane Major Arterial .....	4-39
Exhibit 4.12.6: Cuyamaca Street, On & Off-Site - 2-Lane Parkway Type I.....	4-41
Exhibit 4.12.7: Cuyamaca Street - Residential Collector Type V .....	4-43
Exhibit 4.12.8: Cuyamaca Street - Village Collector .....	4-45
Exhibit 4.12.9: Magnolia Avenue, Off-Site - Collector Type IV .....	4-47
Exhibit 4.12.10: Residential Collector Type I .....	4-49
Exhibit 4.12.11: Residential Collector Type II.....	4-51
Exhibit 4.12.12: Residential Collector Type III .....	4-53
Exhibit 4.12.13: Residential Collector Type VII.....	4-55

---

Exhibit 4.12.14: Residential Street.....	4-57
Exhibit 4.12.15: Carlton Hills Boulevard - Private Street.....	4-59
Exhibit 4.12.16: Split Residential Street (One-Way) .....	4-61
Exhibit 4.12.17: Private Residential Street.....	4-63
Exhibit 4.12.18: Village Street Type I.....	4-65
Exhibit 4.12.19: Village Street Type II.....	4-65
Exhibit 4.12.20: Village Street Type III .....	4-66
Exhibit 4.12.21: Private Residential Driveway .....	4-68
Exhibit 4.13: Trails Map.....	4-70
Exhibit 4.14.1: Multi-Purpose Trail .....	4-71
Exhibit 4.14.2: Village Access Trail .....	4-71
Exhibit 4.14.3: Perimeter Trail.....	4-72
Exhibit 4.14.4: Village Nature Trail .....	4-72
Exhibit 4.14.5: Nature Trail .....	4-73
Exhibit 4.14.6: Primitive Trail.....	4-73
Exhibit 4.14.7: SDG&E Service Road .....	4-74
Exhibit 5.1: Community Organization.....	5-2
Exhibit 5.2a: Fanita Ranch Illustrative Plan (North) .....	5-3
Exhibit 5.2b: Fanita Ranch Illustrative Plan (South) .....	5-4
Exhibit 5.3: Cuyamaca Street Gateway Concept .....	5-6
Exhibit 5.4: Fanita Parkway Gateway Concept.....	5-8
Exhibit 5.5: Conceptual Landmark Imagery.....	5-10
Exhibit 5.6: Fanita Commons Illustrative Plan .....	5-12
Exhibit 5.7: Fanita Commons Imagery .....	5-13
Exhibit 5.8: Fanita Commons Plant Palette .....	5-14
Exhibit 5.9: Orchard Village Illustrative Plan .....	5-19
Exhibit 5.10: Orchard Village Imagery .....	5-20
Exhibit 5.11: Orchard Village Plant Palette.....	5-21
Exhibit 5.12: Vineyard Village Illustrative Plan.....	5-26
Exhibit 5.13: Vineyard Village Imagery.....	5-27
Exhibit 5.14: Vineyard Village Plant Palette .....	5-28
Exhibit 5.15: Community Streets Plant Palette.....	5-33
Exhibit 5.16: Exterior Slopes Plant Palette .....	5-37
Exhibit 5.17: Edible / Medicinal Plant Palette .....	5-39

Exhibit 5.18a: Conceptual Wall and Fencing Plan (North) ..... 5-45

Exhibit 5.18b: Conceptual Wall and Fencing Plan (South) ..... 5-46

Exhibit 5.19: Conceptual Lighting Plan ..... 5-49

Exhibit 7.1a: Conceptual Park, Recreation & Open Space Plan (North) .....7-3

Exhibit 7.1b: Conceptual Park, Recreation & Open Space Plan (South).....7-4

Exhibit 7.2: Community Park Conceptual Plan .....7-8

Exhibit 7.3: Typical Neighborhood Park Concept Plans..... 7-13

Exhibit 7.4: Village Green Concept Plan ..... 7-16

Exhibit 7.5: Typical Mini-Park Concept Plan (MP-20) ..... 7-18

Exhibit 7.6: Conceptual AgMeander Plan..... 7-21

Exhibit 7.7: Typical Linear Park Plan..... 7-24

Exhibit 7.8: Typical Vista Point and Trailhead Concept Plan..... 7-26

Exhibit 8.1: Conceptual Grading Plan .....8-2

Exhibit 8.2: Conceptual Cut & Fill .....8-3

Exhibit 8.3: Conceptual Storm Drainage Plan.....8-6

Exhibit 8.4: Conceptual Sanitary Sewer Plan.....8-8

Exhibit 8.5: Conceptual Water Plan ..... 8-10

Exhibit 9.1: Habitat Preserve Plan.....9-2

Exhibit 10.1: Conceptual Phasing Plan..... 10-3

Exhibit 10.2: Operation & Maintenance Responsibility Areas..... 10-7

---

## List of Tables

Table 3.1: Land Use Plan Statistical Summary.....	3-3
Table 3.2: Site Utilization Plan Statistical Summary .....	3-6
Table 3.3: Special Use Area Permitted Uses and Statistical Summary.....	3-39
Table 4.1: Street Design Criteria .....	4-4
Table 4.2: Traffic Calming Measures .....	4-7
Table 4.3: Trail Design .....	4-69
Table 6.1: Appropriate Building Typologies by Land Use Designation.....	6-27
Table 7.1: Summary of Park and Recreation Land Dedication .....	7-5
Table 7.2: Other Recreation and Open Space Areas .....	7-28
Table B.1: Fanita Ranch Specific Plan Streets .....	B-3



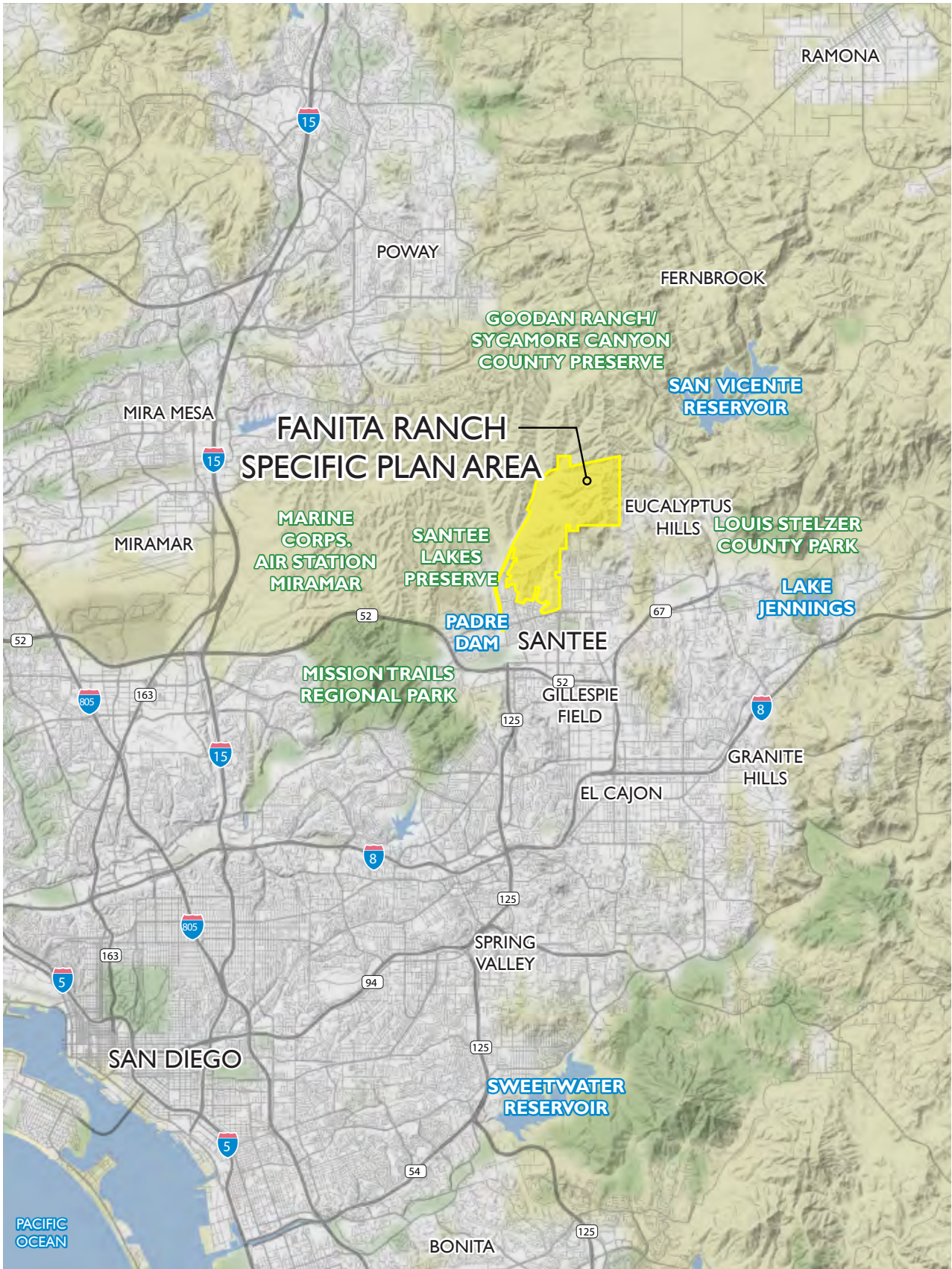
*Intentionally Blank*

# Chapter I: Introduction


## I.1 Project Location and Regional Context

The Fanita Ranch Specific Plan Area consists of approximately 2,638 acres of land located in the northwest quadrant of the City of Santee in eastern San Diego County. Santee is located approximately 18 miles east of downtown San Diego and the Pacific Ocean. Santee is accessible via State Route 52 (SR-52), which connects to Interstate 5 (I-5) and Interstate 805 (I-805) to the west and State Route 67 (SR-67) to the east. SR-67 and State Route 125 (SR-125) both provide connections to Interstate 8 (I-8) south of Santee. From SR-52, Fanita Ranch can be accessed from Fanita Parkway or Cuyamaca Street via Mast Boulevard or the future extension of Magnolia Avenue.

The Specific Plan Area is bordered by existing City of Santee residential neighborhoods to the south and the unincorporated residential communities of Lakeside and Eucalyptus Hills to the east, as illustrated in *Exhibit 1.1: Project Location and Context*. Sycamore Canyon County Preserve and Goodan Ranch Regional Park are to the north. Goodan Ranch Regional Park is jointly owned by the Cities of Santee and Poway, the County of San Diego and the State of California. These open space areas include existing and potential trail connections into Fanita Ranch including Stowe County Trail, which currently extends through Fanita Ranch along Sycamore Creek. Stowe County Trail also provides access to Mission Trails Regional Park, a 5,800-acre open space preserve in the City of San Diego, located adjacent to the City of Santee's western corporate limit. Marine Corps Air Station Miramar and Padre Dam Municipal Water District facilities, including Santee Lakes Recreation Preserve, lie west of the Specific Plan Area. Santee Lakes Recreation Preserve consists of recycled water ponds surrounded by campgrounds with tent and recreational vehicle (RV) sites and rental cabins. The facility offers fishing, boating, camping, picnicking and other recreational activities, as well as RV storage.



**Exhibit I.1: Project Location and Context**

 not to scale

## **I.2 Regulatory Context**

### **I.2.1 Specific Plan Authority**

California State law authorizes cities to prepare and adopt specific plans for the systematic implementation of the general plan for all or part of the area covered by the general plan (Government Code Section 65450). Specific plans contain both planning policies and regulations, and may combine zoning regulations, capital improvement programs, detailed development regulations, and other regulatory requirements into one document, which are designed to meet the needs of a specific area. Specific plans may be adopted by resolution or by ordinance. The Fanita Ranch Specific Plan is regulatory in nature and will be adopted by ordinance by the City of Santee.

The Santee General Plan identifies Fanita Ranch as an area for special study requiring the preparation of a Specific Plan for a variety of reasons, as summarized below:

- The site has varied topography, scenic resources, and significant vegetation and habitats found nowhere else in the City limits.
- It is the largest single ownership area in the City and represents an area of tremendous development potential.
- Potential natural hazards related to slope stability and geologic resources exist within this area.
- The development of Fanita Ranch will have a significant, positive economic impact on the rest of the City, through increased property taxes and sales taxes generated by increased sales at local businesses.
- Fanita Ranch is the only remaining area in the City where a significant number of new housing units can be built. The project will increase the much needed housing stock in Santee and will offer a variety of home sizes with a range of market rate prices. The additional housing supply and residents could attract new businesses and office users to the City's planned office and technology parks.

### **I.2.2 Specific Plan Purpose**

The Fanita Ranch Specific Plan provides an opportunity to balance the City's need for diverse housing types and high-quality amenities, while restoring and preserving sensitive habitat areas. The Specific Plan provides guidance to ensure development occurs thoughtfully and responsibly. The purpose of the Specific Plan is to implement the Santee General Plan, and create a unique community where nature is the defining and unifying theme for the community. Access to fresh and healthy food, life-long learning, opportunities for active and healthy lifestyles, and a wide range of housing types and



sizes to accommodate a variety of incomes, ages and abilities, and an array of life stages and interests further define the community. The Specific Plan is designed to ensure fiscally sound development by balancing appropriate land uses and providing flexibility in the plan to respond to changing market conditions through the provision of diverse housing types and sizes supported by adequate services and infrastructure. The Specific Plan also provides permitting procedures and development standards, design guidelines, financing mechanisms, maintenance entities and phasing to ensure proper implementation, operation and maintenance of the community over time.

### **1.2.3 Relationship to the Santee General Plan**

The Santee General Plan Map designates Fanita Ranch as “Specific Plan (SP)” and identifies Guiding Principles for the Fanita Ranch Specific Plan Area. These Guiding Principles serve as a basis for the planning decisions that led to the development of the Fanita Ranch Specific Plan. In addition to the Guiding Principles, the Specific Plan is consistent with the applicable goals and policies of the General Plan. A detailed analysis of the goals and policies applicable to Fanita Ranch is provided in the Fanita Ranch Environmental Impact Report (EIR).

The Santee General Plan Guiding Principles for Fanita Ranch, and a brief explanation of how the Specific Plan implements and is consistent with each, follow:

1. The Specific Plan should include a comprehensively planned, high architectural quality, mixed-use Village Center that allows for housing, retail, office and service uses.

***Response:***

*Chapter 3: Land Use & Development Regulations of the Specific Plan establish a Village Center in each Fanita Ranch Village that permits a mix of housing, retail and office uses. Chapter 5: Landscape Architecture, Community Design & Outdoor Lighting Design Plan establishes a unique design theme which supports the overall Fanita Ranch community’s agrarian design theme, and Chapter 6: Architectural Design Guidelines provides design guidance for buildings within Village Centers.*

2. The Specific Plan shall provide a community-focused Village Center that includes provisions for public parks, residential, office, commercial development and institutional uses such as schools, fire station, branch post office, and other civic and community uses.

***Response:***

*The Fanita Commons Village Center will provide a centralized community hub that will provide housing and everyday retail, services and civic uses. The Village Center is located near the proposed school site, fire station, parks and the Farm.*

3. The plan shall allow for a diversified mix of housing types and sizes.

**Response:**

*Chapter 3: Land Uses & Development Regulations* establishes Village Center, Medium Density Residential, Low Density Residential and Active Adult land use designations that allow for a diversified mix of housing types ranging from stacked flats to single family homes in a variety of configurations and sizes to accommodate a variety of incomes, ages and abilities and an array of life stages and interests.

4. The Land Use Plan, Mobility Plan, Trails and Open Space Plan, and Illustrative Site Plan shall be sensitive to the preservation of natural land forms and sensitive habitat areas by clustering development to minimize the development footprint and by establishing site specific design standards which provide for development in harmony with the environment.

**Response:**

Development is clustered into three Villages to avoid the most sensitive habitat areas on the site, preserve known wildlife corridors and maintain a contiguous and connected open space system. The prominent hilltop in Fanita Commons has been preserved within the planned Community Park. Where development is proposed on hillsides, grading will be efficient to minimize the grading footprint. Special contour grading techniques will be utilized at edges and transitions and land form grading techniques will be used on steep slopes that are visible from the public rights-of-way, as identified in *Chapter 8: Grading, Utilities & Services*. Within the Habitat Preserve, existing trail alignments will be used to the greatest extent possible, with new trails to be added at select locations to provide connections for recreation, fuel modification and habitat enhancement and restoration purposes. Some existing trails will be closed and habitat restored. Trail locations will be carefully coordinated to minimize potential conflicts with sensitive habitat areas.

5. The Specific Plan shall permit grading of steep slopes to minimize the development footprint. The plan should include site specific design standards that are sensitive to transitional edges between steep slopes and natural topography where feasible, particularly at the edges of the development area and along steep slopes visible from the public rights-of-way.

**Response:**

Within the hillside areas where development is proposed, grading will be efficient to minimize the grading footprint. Special contour grading techniques will be utilized at edges and transitions to closely mimic the natural contour intervals, and land form grading techniques will be used on steep slopes, as identified in *Chapter 8: Grading, Utilities & Services*, that are visible from the public rights-of-way to recreate and mimic the flow of natural contours and drainages within the natural surroundings.



6. The Specific Plan shall incorporate smart growth, clustering, and sustainability principles, as practicable, to preserve open space, minimize the consumption of natural resources, conserve water and energy, and promote walkable development.

**Response:**

*Development is clustered into three efficient Villages to preserve approximately 63% of the site as Habitat Preserve open space. Within the development footprint, low-impact development techniques are proposed to manage storm water runoff. Advanced Treated Water will provide a local, reliable and sustainable water supply to the Specific Plan Area. Water-efficient landscaping, weather-based irrigation controllers, and water efficient appliances, fixtures and water closets in all buildings will further conserve water and energy. Energy efficiency will be achieved by planting shade trees, installing energy efficient appliances and utilizing passive building design techniques to minimize heat islands and conserve energy. Solar panels on buildings, the Special Use Area community-level solar farm, carports and in other potential locations throughout the community will generate electricity. A comprehensive network of trails and sidewalks is provided to promote walkability, which will be enhanced by tree-lined walkways, pedestrian oriented architecture and other pedestrian-focused amenities.*

7. The Specific Plan should contain mini-parks, neighborhood parks, and a community park as required by the recommendations of the Recreation Element of the General Plan.

**Response:**

*Chapter 7: Parks, Recreation & Open Space describes the proposed system of parks and recreation facilities, which consists of mini-parks, neighborhood parks and a community park consistent with the General Plan.*

8. The plan shall contain a small working farm that demonstrates the use of permaculture techniques.

**Response:**

*The Specific Plan designates 38.2 acres of land for Agricultural uses, including 27.3 acres of consolidated area for the development of a centralized farm in Fanita Commons. In addition, many of the parks and recreation areas are envisioned to incorporate edible landscape materials and community gardens. Education programs for homeowners to encourage the use of sustainable and edible vegetation on individual lots will be provided at the Farm. The nearby K-8 school site will provide the school district with the opportunity to incorporate agricultural activities into the education curriculum and explore “farm lab” opportunities, which will give students access to healthy, locally grown food, school gardens and educational opportunities.*

9. The Specific Plan shall include the extension of Fanita Parkway along the western boundary of the property.

**Response:**

*The Specific Plan provides street improvement standards in **Chapter 4: Mobility** that include the extension of Fanita Parkway along the western boundary of the Specific Plan Area.*

10. The Specific Plan shall include the extension of Cuyamaca Street into the site, ultimately connecting with Fanita Parkway consistent with the General Plan.

**Response:**

*The Specific Plan provides street improvement standards in **Chapter 4: Mobility** that include the extension of Cuyamaca Street into the Specific Plan Area, connecting to Fanita Parkway via a new collector street.*

11. The Specific Plan shall include a comprehensive system of trails as part of the overall Mobility Plan. Trails shall link with the proposed trails outside Fanita Ranch, which is consistent with the objectives and standards set forth within the City's adopted Trails Element to the General Plan. Access to Sycamore Canyon County Preserve shall be provided to Santee residents. Trail access shall be subject to the Natural Community Conservation Planning (NCCP) design guidelines and standards.

**Response:**

***Chapter 4: Mobility** establishes an extensive trail system that includes multi-purpose trails and sidewalks along the streets and trails in the open space areas and Habitat Preserve. This pedestrian circulation system provides a variety of connections throughout the Specific Plan Area, including access to the Habitat Preserve within Fanita Ranch and the adjacent open space areas such as Goodan Ranch Regional Park and the Sycamore Canyon County Preserve. Trail access will be subject the requirements and provisions of the NCCP design guidelines and standards.*

12. The Fanita Ranch area shall not be subdivided until a Specific Plan is adopted by the City of Santee.

**Response:**

*The Specific Plan includes provisions for subsequent entitlement applications, including all subdivisions within the Specific Plan Area, which cannot occur until after the adoption of the Specific Plan.*

13. To ensure that proposed development is appropriate, the Specific Plan shall contain schematic or illustrative development plans which show prototypical circulation systems, all proposed land uses, and potential residential product types.

***Response:***

*Prototypical circulation systems are provided in Chapter 4: Mobility. Proposed land uses are described in Chapter 3: Land Uses & Development Regulations. Potential residential product types for applicable land use districts are identified in Chapter 3: Land Use & Development Regulations and further described in Chapter 6, Architectural Design Guidelines.*

### **1.2.4 Relationship to the Santee Zoning Ordinance**

The City of Santee Zoning District Map designates the Fanita Ranch property as “Specific Plan (SP).” The “Specific Plan (SP)” designation allows zoning to be administered through the Fanita Ranch Specific Plan. The Fanita Ranch Specific Plan provides a unique set of development standards that allow for creative housing types and use configurations not currently addressed in the City’s existing Zoning Ordinance. Providing a variety of housing and lifestyle choices fulfills a key objective of the Santee General Plan. New and innovative housing types and configurations included in the Specific Plan promote shared amenities, walkability and housing attainability by creating greater energy efficiency and addressing the diverse range of incomes, lifestyles, special needs and household types in Santee and the greater San Diego County region.

### **1.2.5 Airport Compatibility**

Fanita Ranch is located in the vicinity of two airports: Marine Corps Air Station (MCAS) Miramar and Gillespie Field. The Airport Land Use Commission for San Diego County adopted Airport Land Use Compatibility Plans (ALUCPs) for each airport that establish land use compatibility policies and development criteria for new development within Airport Influence Areas to protect these airports from incompatible land uses and provide the City with development criteria that will allow for the orderly growth of the areas surrounding the airports. Compatibility concerns addressed by the ALUCPs include noise, safety, airspace protection, and overflight.

Fanita Ranch abuts the easterly property line of the MCAS Miramar. The Specific Plan Area is within the Federal Aviation Regulations (FAR) Part 77 Outer Boundary, and the easterly portions of the site are within a High Terrain zone; however, only a small northerly portion of the site falls within Review Area 2 of the Airport Influence Area. Since the portion of the site within Review Area 2 will be dedicated as Habitat Preserve and will not be developed, and the remainder of the property is located outside of any Airport Influence Area, the proposed Specific Plan is not subject to any land use restrictions because of MCAS Miramar. In addition, the areas proposed for development fall outside of any Overflight Zones and are not subject to overflight-related disclosure or notification requirements.

Fanita Ranch is located north of Gillespie Field. Southerly portions of the site are located within the Federal Aviation Administration (FAA) Height Notification Boundary and are proposed as Habitat Preserve and Special Use Area. Within this boundary, the FAA shall be notified of any proposed construction or alteration having a height greater than an imaginary surface extending 100 feet outward and 1 foot upward (slope of 100 to 1) from the runway elevation. The Special Use Area also falls within Review Area 2, which requires limitations on the height of structures. Review Area 2 also requires overflight notification documents for residential uses; however, residential uses are not permitted within the Special Use Area, except for a caretaker unit as described in *Section 3.2.9: Special Use*. If a caretaker unit is proposed, notification in accordance with Review Area 2 requirements will be made.

### **1.2.6 Relationship to Other City Documents**

Wherever this Specific Plan contains provisions which differ from those provisions contained in other adopted City codes and regulations, the Specific Plan shall prevail and supersede the applicable provisions of that Code. Where the Specific Plan is silent on a particular issue, the City of Santee Zoning District Map and Zoning Ordinance shall prevail.

### **1.2.7 Legal Significance and CEQA**

The Fanita Ranch Specific Plan is subject to the California Environmental Quality Act (CEQA). All mitigation measures and monitoring activities identified by the Environmental Impact Report (EIR) prepared for the Specific Plan and incorporated into the Fanita Ranch project shall be implemented through the Specific Plan. All future discretionary permits shall be consistent with the Specific Plan.

## **1.3 Document Organization**

### **1.3.1 Specific Plan Organization**

The Fanita Ranch Specific Plan contains 10 chapters and 2 appendices. Below is a summary of each chapter contained in the Specific Plan:

- *Chapter 1: Introduction* explains the physical and regulatory setting of the Specific Plan Area, as well as the organization of the Specific Plan.
- *Chapter 2: Overview* discusses the history of the Specific Plan Area and summarizes the overall vision and inspiration for Fanita Ranch.
- *Chapter 3: Land Use & Development Regulations* establishes land use designations, permitted uses for each land use designation, and development standards such as setbacks, building height, parking, open space and more.

- *Chapter 4: Mobility* summarizes the Specific Plan Complete Streets roadway system, establishes Specific Plan street sections unique to Fanita Ranch and addresses alternative modes including walking, biking and transit.
- *Chapter 5: Landscape Architecture, Community Design & Outdoor Lighting Design Plan* discusses the community organization, landscape themes and concepts for the three Villages, plant palettes, brush management/fuel modification, walls/fencing and outdoor lighting.
- *Chapter 6: Architectural Design Guidelines* provides guidelines for building typologies, appropriate architectural styles and building design.
- *Chapter 7: Parks, Recreation & Open Space* describes the various parks and recreational amenities provided in Fanita Ranch, consistent with the applicable goals and objectives of the Santee General Plan Recreation Element and Santee Municipal Code park land dedication requirements.
- *Chapter 8: Grading, Utilities & Services* presents the overall grading concept and identifies major backbone utilities necessary to serve future development within the Specific Plan Area. A description of how public services, including fire protection, law enforcement, education and other public services, will be provided for future residents and businesses is also included.
- *Chapter 9: Open Space, Conservation & Sustainability* explains the wide range of conservation strategies, including habitat and cultural resource protection and water and energy conservation, and sustainability objectives and potential features that may be implemented in Fanita Ranch.
- *Chapter 10: Implementation* discusses the required public improvements, phasing, financing mechanisms and operation and maintenance responsibilities, and explains how the Specific Plan will be administered.
- The Specific Plan appendices include the following:
  - » *Appendix A: Definition of Terms*
  - » *Appendix B: Fanita Ranch Street Design*

### **1.3.2 Technical Studies and Supporting Documents**

A number of technical studies and supporting documents have been prepared to address the design, environmental, engineering, financial and operational aspects of Fanita Ranch. Together, these studies and documents contribute to the formulation of the planning concepts presented in the Fanita Ranch Specific Plan, support the analysis and conclusions contained in the Fanita Ranch EIR, and identify the public services/improvements funding sources and ongoing operation and maintenance responsibilities/

costs associated with implementation of the Specific Plan. In most instances, the Specific Plan provides a summary of the technical studies and supporting documents. Most of the technical studies are under separate cover and provided as appendices to the EIR. Below is a list of the technical studies and supporting documents prepared for Fanita Ranch:

- Vesting Tentative Subdivision Map (herein referred to as Tentative Map)
- Visual Simulations (EIR Appendix B)
- Air Quality Analysis (EIR Appendix C1)
- Health Risk Assessment (EIR Appendix C2)
- Biological Resources Technical Report (EIR Appendix D)
- Cultural Resources Phase I Survey Report (Confidential) (EIR Appendix E1)
- Phase II Cultural Resources Testing and Evaluations Report (Confidential) (EIR Appendix E2)
- Tribal Cultural Resources Memorandum (Confidential) (EIR Appendix E3)
- Phase I In-Fill Pedestrian Surveys (Confidential) (EIR Appendix E4)
- Energy Analysis Report (EIR Appendix F)
- Geotechnical Investigation for Fanita Ranch and Off-Street Improvements (EIR Appendices G1-G3)
- Geologic Reconnaissance for Fanita Ranch and Off-Street Improvements (EIR Appendix G4)
- Paleontological Resource Assessment (EIR Appendix G5)
- Greenhouse Gas Analysis (EIR Appendix H)
- Phase I Environmental Site Assessment (EIR Appendix I)
- Master Drainage Study (EIR Appendix J1)
- Priority Development Project Stormwater Quality Management Plan (EIR Appendices J2-J3)
- Green Streets Priority Development Project Exempt Stormwater Quality Management Plan (EIR Appendix J4)
- Stormwater Infiltration Feasibility Study (EIR Appendix J5)
- Potential Critical Course Sediment Yield Area Analysis (On-Site) (EIR Appendix J6)
- Potential Critical Course Sediment Yield Area Analysis (Off-Site) (EIR Appendix J7)
- Aggregate Report (EIR Appendix K)
- Noise Technical Report (EIR Appendix L)
- Public Services Will Serve Letters (School, Police, Fire, and Waste Management) (EIR Appendix M)
- Traffic Impact Analysis, Vehicle Miles Traveled Analysis and Transportation Demand Management Plan (EIR Appendix N)
- Water Service Study (EIR Appendix O1)
- Sewer Service Study (EIR Appendix O2)
- Water Supply Assessment (EIR Appendix O3)
- Dexter Wilson Report (EIR Appendix O4)
- Fire Protection Plan and Construction Fire Protection Plan (EIR Appendix P1)
- Wildland Fire Evacuation Plan (EIR Appendix P2)

## I.4 Development Approvals

The following discretionary approvals and permits are associated with the Fanita Ranch project:

- Environmental Impact Report;
- Santee General Plan Amendment;
- Specific Plan;
- Zoning Amendment or Reclassification;
- Vesting Tentative Map;
- Development Review Permit(s);
- Development Agreement; and
- Conditional Use Permits (Public Parks).

The following future discretionary approvals and permits from the City of Santee and other agencies including, but not limited to the following, may be required:

- Section 404 Permit - Clean Water Act
- Endangered Species Act - Section 7 Consultation or Section 10 (a) Incidental Take Permit, if needed
- California Fish & Game Code Section 1600 et. seq - Streambed Alteration Agreement/  
Memorandum of Understanding
- Clean Water Act Section 401 Permit - Water Quality Certification
- National Pollutant Discharge Elimination System Permit; General Construction Activity Storm  
Water Permit, including Storm Water Pollution Prevention Plan (SWPPP)
- General Construction Storm Water Permit
- Air Quality Permit to construct/permit to operate



# Chapter 2:

## Community Vision

### 2.1 Fanita Ranch History

Fanita Ranch has a long and rich agricultural legacy. The indigenous Kumeyaay people gathered edible plants, collected acorns, hunted on this site, built temporary communities, and expressed their spirituality here. Arriving in 1769, the Spanish mission fathers used the area for grazing. A Spanish land grant to Dona Maria de Pedorena in 1845 continued this practice. George and Jennie Cowles arrived in 1877 looking for a healthier environment, having suffered poor health on the east coast. George, experienced in farming, machinery, business and finance from previous ventures, purchased a large tract of land that included Fanita Ranch, and planted fruit trees, grapevines to produce raisins, olives, grains and potatoes. After George's death in 1887, Jennie remarried surveyor and land investor Milton Santee in 1890, who had a penchant for naming new towns, and the community soon adopted "Santee" as its name.

A regional train line arrived in the El Cajon valley in 1899 to service the rapidly growing towns of El Cajon and Lakeside. Santee remained a sparsely populated rural agricultural and ranching center. In 1912, Santee consisted of a train depot platform, general store, schoolhouse, church, hotel, blacksmith shop, hardware store, feed store, and small family farms and ranches. The tract of land that would become Fanita Ranch remained largely untouched during this period. Hosmer and Fannie McKoon purchased 10,000 acres in Santee in 1885 and named the property Fanita Ranch. The famous San Diego Scripps family bought the ranch in 1898, and used the land for a vacation home, and cattle and horse ranching. Josephine Scripps inherited the ranch and began operating a full working ranch on the property by 1941.

Following World War II, newcomers flooded into Southern California for jobs and the climate. Santee quickly became a suburb of San Diego. William Mast completed the largest County land transaction at the time when he paid \$1 million for 4,300 acres of the Fanita Ranch property for the newly formed Carlton-Santee Corporation. Residential subdivisions soon followed, and Santee grew from less than 2,000 residents in 1950, to more than 11,000 by 1960, and 26,000 by 1970. Mast's new "planned



community” included a golf course, parks, schools, and retail centers. Santee was incorporated as a city in 1980.

## 2.2 Specific Plan Objectives

The Santee General Plan designates Fanita Ranch as “Specific Plan” and establishes Guiding Principles as discussed in *Section 1.2.3: Relationship to the Santee General Plan*. The Specific Plan addresses land uses, mobility, public facilities, parks, recreation and open space, development regulations and design guidelines, and implementation. The objectives of the Specific Plan are provided below.

### 2.2.1 Land Use Planning and Community Design Objectives

- A. Create a new community that includes residential, commercial and agricultural land uses integrated with parks, recreational and public facilities, while establishing large, continuous natural open space as a Habitat Preserve.
- B. Cluster development into three connected Villages to preserve regionally significant natural resource areas, sensitive habitat and substantial landforms.
- C. Create development and land use patterns that are compatible with existing surrounding communities and land uses.
- D. Establish an agrarian-focused community centered on a working farm along with orchards and vineyards, where residents can connect with each other and with the land.
- E. Provide mixed-use Village Centers that serve as the social and commercial hub of each Village, with a complementary mix of land uses, services and facilities located within walking distances.
- F. Organize the community into Villages with individually unique identities and sense of place, while linking the Villages through physical and visual connections with key destinations and amenities.
- G. Encourage emerging housing concepts and provide a wide variety of housing types and sizes that respond to the City’s housing demands and appeal to a diverse range of incomes, ages, households and lifestyles.
- H. Design intimate, connected neighborhoods with authentic architecture and a human-scaled physical and social environment.

- I. Utilize smart growth principles that advocate thoughtful and sustainable development patterns to conserve resources, reduce impacts on the environment, promote active lifestyles, support livability, offer social engagement opportunities and achieve fiscal sustainability.
- J. Implement a comprehensive Fire Protection Plan that results in a fire-safe and fire-aware community through a multi-layered fire protection approach.

### **2.2.2 Mobility Objectives**

- A. Provide a highly connected Complete Streets system that supports various modes of transportation and offers alternatives to single occupancy vehicle travel.
- B. Create a safe and efficient circulation system that optimizes connectivity among land uses, minimizes impacts on environmentally sensitive areas and addresses functionality, aesthetics and traffic calming.
- C. Design a comprehensive trail system that accommodates a variety of users, connects Villages and community amenities, maximizes views, protects sensitive habitat areas and provides linkages to local and regional parks and trails.

### **2.2.3 Recreation and Open Space Objectives**

- A. Create an interconnected recreation and open space network that includes active and passive parks, trails and bikeways, recreational facilities and natural open space that meet the recreational needs of Fanita Ranch residents and visitors.
- B. Provide a community park, neighborhood parks and mini-parks and well-connected trails that meet the General Plan objectives, satisfy the parkland dedication requirements and meet the recreational needs of the residents.
- C. Provide an extensive system of pedestrian, bicycle and hiking trails for use by the public that connects neighborhoods within the community and links to regional trail and recreational facilities and open space areas.
- D. Protect open space and natural habitat areas that are a vital component of the health and well-being of the community and the environment.

### **2.2.4 Resource Conservation Objectives**

- A. Establish a Habitat Preserve to protect important natural, biological and cultural resources and assure continued support for sensitive species and their habitats through the implementation of

long-term preserve management consistent with the Natural Community Conservation Planning (NCCP) design guidelines and standards.

- B. Preserve open space connectivity and allow for continued wildlife movement through the site.
- C. Implement sustainable development practices to ensure water and energy conservation, reduce greenhouse gas emissions and air quality impacts, facilitate alternative modes of transportation, encourage material conservation and reuse, and promote active and healthy lifestyles.
- D. Protect water quality through a comprehensive Low Impact Development (LID) approach that maintains a landscape functionally equivalent to pre-development hydraulic conditions and minimizes the generation of pollutants of concern.

### **2.2.5 Economic Objectives**

- A. Provide an adequate level of private development to ensure the economically feasible provision of public facilities and services required to serve the community.
- B. Create housing, commercial and employment opportunities that contribute to the economic viability of the City of Santee and Fanita Ranch.
- C. Adopt development regulations and design guidelines that encourage design innovation and provide flexibility to respond to changing economic and market conditions through build-out of the community, while establishing guidance for implementing the vision for Fanita Ranch.
- D. Adopt development regulations and design guidelines that allow for clustering of development, parking and facility sharing and other innovations which reduce the costs of providing public services.

## 2.3 Community Vision

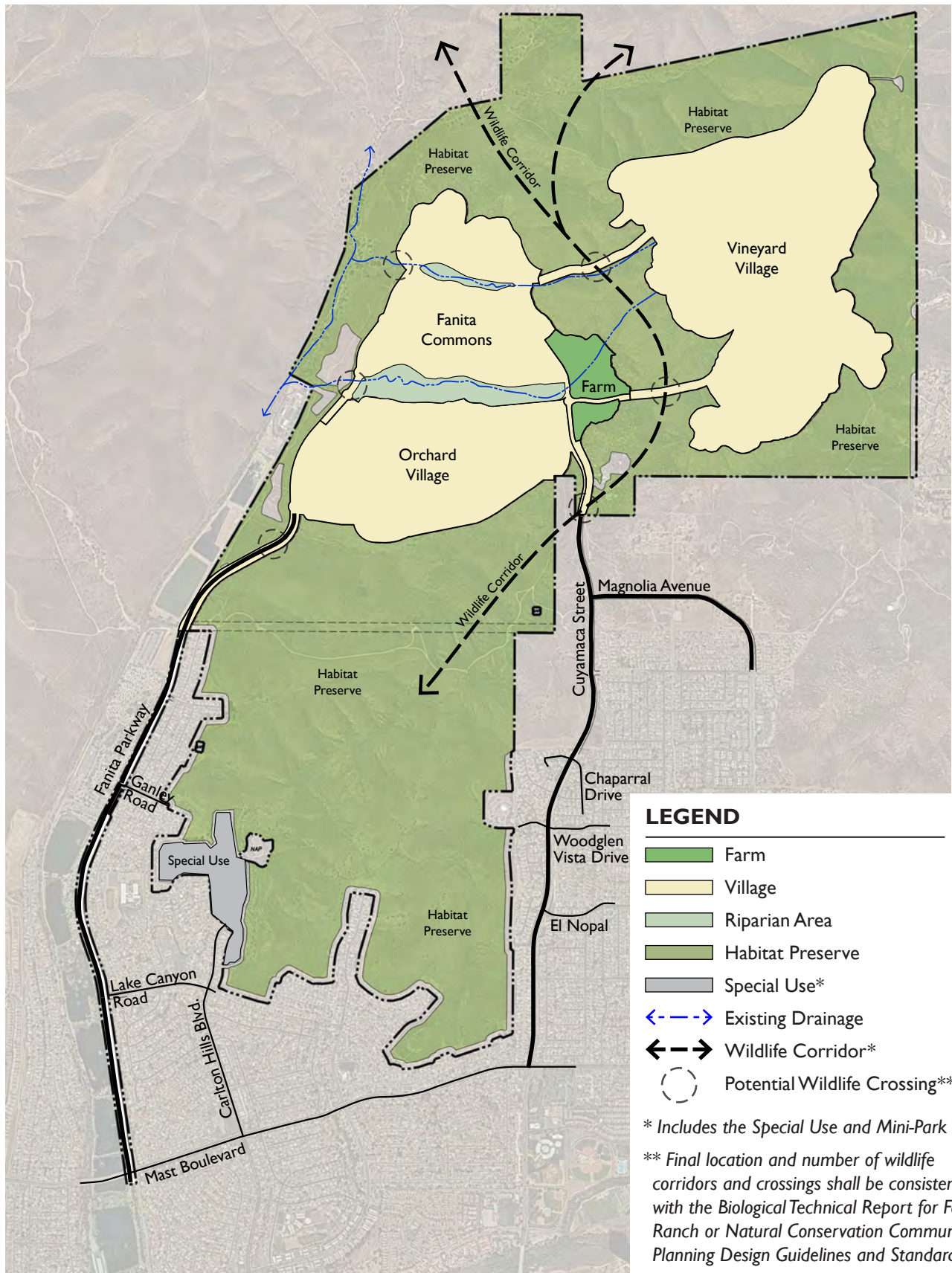
Fanita Ranch proposes to make wellness a central theme of its development by focusing on the character of rural living: sensitive, sustained use of the land; an appreciation for nature; financially feasible food production; friendly hospitality; and healthy and active lifestyles. The design of Fanita Ranch focuses on a wide range of wellness and sustainability development features, including an extensive trails system, a community farm, orchards, vineyards and gardens throughout the community that promote healthy living and a thriving and protected natural environment.

Habitat on the Fanita Ranch property has been severely degraded over the past few decades by illegal activities including trespassing, dumping, and off-road vehicle use. By clustering compact, walkable, sustainable, low impact development in strategic locations that minimize ecological impacts, development of the Fanita Ranch Specific Plan will allow for the restoration of sensitive habitat areas and management of the Habitat Preserve. Implementation of the Specific Plan includes establishment of a formal management entity and management plan to monitor and protect biodiversity. Furthermore, creating neighborhoods adjacent to a public trail system and providing community education programs about the area's natural resources will encourage community appreciation for nature, foster a sense of ownership and stewardship for the land, and encourage voluntary participation in preserving and maintaining these open spaces from further degradation. Fanita Ranch will preserve approximately 63% of the site in a Habitat Preserve, including many of the rock formations and vistas that characterize the property.

Development has been clustered into three unique Villages to protect the most ecologically and culturally sensitive areas on the property. These Villages include Fanita Commons, Orchard Village and Vineyard Village, as shown in *Exhibit 2.1: Development Concept*. Wide open space corridors between the Villages preserve connectivity and allow for continued wildlife movement through the site. Wildlife crossings at roadways are carefully and thoughtfully designed to support the safe and efficient movement of animals. In addition, existing drainages between the Villages allow for revegetation and restoration of these important features, which provide habitat and connectivity for wildlife.

As a community with a focus on health, wellness and life enrichment, Fanita Ranch incorporates agrarian lifestyle amenities which demonstrate the heart and identity of the community. The agrarian lifestyle at Fanita Ranch will be focused on enhancing the quality of life for residents through improving access to fresh local foods, creating wellness opportunities and offering community connections tied to the land. The Farm will offer educational programming, community events and retail opportunities aimed at providing residents and guests of all ages with unique, authentic experiences that foster community engagement and well-being.

The Farm is the centerpiece of Fanita Ranch and honors Santee's long tradition of agriculture. The Farm is intended to help "sow the seed" for community engagement and encourage everyone to connect with



**Exhibit 2.1: Development Concept**

⊕ not to scale



their food and the land. Community agriculture fosters the values of relationship-building, enrichment and creates a sense of place by bringing people together around an essential part of life – food. The Farm will be designed to create a symbiotic relationship with the community: the Farm can nurture the community and the community can nurture and support the Farm.

Located at a prominent location in Fanita Ranch, the Farm is planned to include a large barn that will set the architectural theme of the community and provide a venue for special events and farm operations. The working farm will also include terraced vegetable fields, pasture lands, limited housing for employees, raised gardens and small-scale animal husbandry. A Community Supported Agriculture (CSA) program, sometimes called a “subscription farm” because the consumer receives produce on a regular basis, will be offered. Food grown on the Farm may also be distributed to local schools, restaurants and other institutional facilities such as congregate care and assisted living facilities.

The Farm will allow for a range of community activities including farm-to-table events, community harvests, weddings and other celebrations and festivals. Farm-based education will be provided in the form of tours, volunteer opportunities, camps, workshops related to gardening and farmer training, nutrition, cooking, herbal medicines, home preservation of food and more. Within the adjoining Village Center, a Village Green will allow farm activities such as farmers markets and festivals to expand into the Village Center. Potential uses within the Village Center includes a retail nursery, gourmet farm-to-table restaurants, artisan bakeries or cheese-makers, craft breweries or other gourmet food shops.



*The Farm allows for a range of educational opportunities and social events such as farmer training workshop, education gardens and weddings.*

In addition to the Farm, Fanita Ranch will extend the agricultural theme throughout the community by incorporating additional agrarian components:

- *Orchards and Vineyards:* Fruit and nut tree orchards will add both aesthetic and health benefits to the Fanita Ranch landscape. They will add to economic opportunities for the Farm, provide food for the community, support wildlife habitat and enhance the rural character of the land.
- *Community Gardens:* Community gardens bring residents together to share, learn and grow food in a beautiful, accessible and nourishing space. These gardens provide fresh produce and plants as well as satisfying labor, neighborhood improvement, a sense of community and a connection.
- *Residential Gardens:* These gardens are intended to provide residents with an opportunity to grow food around their home. HOA regulations and guidelines will encourage native, edible and drought tolerant landscaping.
- *Edible Landscaping:* Edible streetscaping and landscaping is a hybrid between farming and landscaping in which greenspaces are used to grow food. Texture, color, seasonality and taste are all factors in designing an edible landscape. Fruit trees, berries, herbs, edible flowers and perennial plants make beautiful, delicious and functional options along streets, in park and in other landscaped areas throughout Fanita Ranch.



*The Farm offers a variety of activities and features such as “farm-to-table” events, small animal husbandry, community gardens, and vegetable fields.*



- *AgMeander*: An “AgMeander” is a series of trails and paths that unite nature and agriculture in an experiential journey. At Fanita Ranch, the AgMeander connects the central community Farm to the Villages, school site, parks and residences. It integrates agriculture into the entire community and strengthens its connection to the trails and open space. The AgMeander provides exercise and recreational activities in which people can hike, run and bike throughout the agricultural setting. It provides context for food production and is an example of how everyday landscape can be ornamental and edible.

The Farm is just one aspect of Fanita Ranch’s emphasis on healthy living. The design of Fanita Ranch will give residents and the entire community of Santee an opportunity to embrace wellness, as described below:

- A K-8 school site will be located near the Farm to provide the school district with the opportunity to incorporate agricultural activities into the curriculum and to explore “farm lab” opportunities, which give students access to healthy, locally grown food, school gardens and educational opportunities.
- An extensive trail system will connect to existing trails networks in the Goodan Ranch/ Sycamore Canyon County Preserve, Mission Trails Regional Park, and Santee Lakes Preserve to encourage outdoor activity and exercise.



*Fanita Ranch’s extensive trail system creates a highly connected community with opportunities for walking, hiking and biking.*



- Every home will be within walking distance of a park or a trail. Active sports-oriented parks, playgrounds, gardens and seating areas with views that provide meditative space will be spread throughout the community to allow residents ample opportunities for outdoor recreation.
- Traffic-calming innovations, such as narrowed streets, roundabouts, enhanced pedestrian crossings and landscaped parkways will make the roads safer and more inviting to pedestrians and bicyclists, encouraging active lifestyles.
- The design of Fanita Ranch will encourage social wellness with everyday interactions with nature and wildlife, farming and gardening and neighbors.
- The Village Centers will allow for co-working spaces and live-work units, which have the potential to reduce or eliminate commute times, thereby reducing stress and promoting wellness.
- Village Centers will allow for and encourage a wide range of health and wellness services including health spas, gardens, meditation and therapeutic garden spaces, religious and spiritual institutions, congregate care facilities, healthy restaurants and specialty markets and private recreation facilities.



*The Specific Plan allows for and encourages uses that focus on health and wellness, stress reduction, healthy eating and activities and community support.*

# Chapter 3:

## Land Use & Development Regulations

### 3.1 Land Use Plan

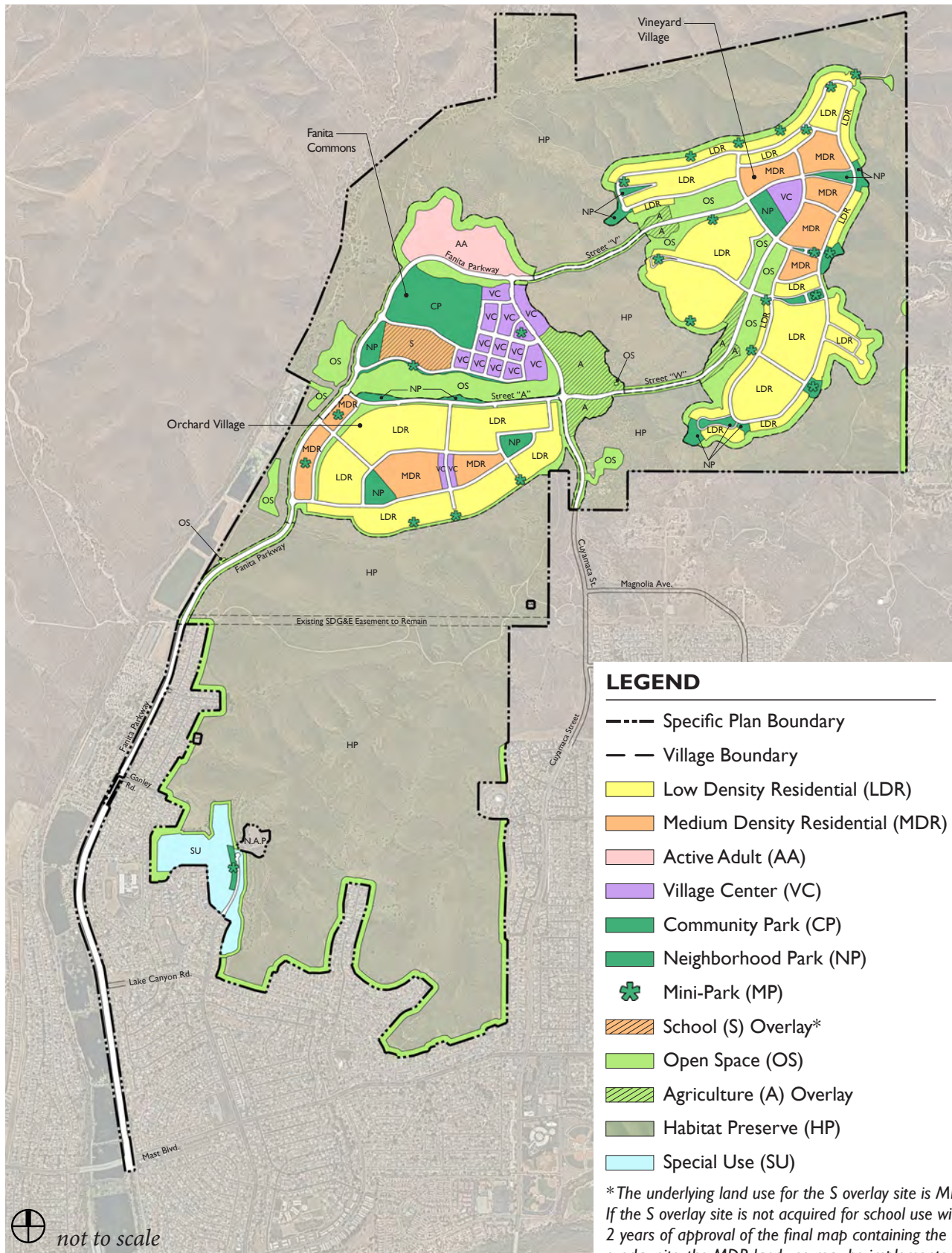
#### 3.1.1 Land Use Plan Description

The Fanita Ranch Specific Plan proposes residential, mixed-use Village Center and agricultural uses, as well as a K-8 school site, parks, open space and a Special Use area. An overview of how the land uses are arranged is illustrated in *Exhibit 3.1: Land Use Plan* and is summarized in *Table 3.1: Land Use Plan Statistical Summary*.

In keeping with the Village concept described in *Chapter 2: Community Vision*, development is clustered into three Villages to preserve natural open space areas, drainages and key wildlife corridors: Fanita Commons, Vineyard Village and Orchard Village. Villages are arranged around a centralized Farm that will provide food and a focal point for the community. Additional agricultural areas are permitted throughout the Villages to support farming and wellness as the central theme for Fanita Ranch. Fanita Commons serves as the main Village and includes a Village Center that consists of a mix of retail, residential, civic and office uses, with a strong physical connection to the central Farm. A Village Green provides a central gathering place for the community and allows farm events to extend into the Village Center. Fanita Commons also includes a Community Park, a neighborhood park, a K-8 school site and an Active Adult neighborhood. The Vineyard and Orchard Villages include smaller mixed-use Village centers that allow for neighborhood serving uses, office space and other community services and amenities, as well as Medium Density Residential and Low Density Residential neighborhoods. A variety of parks are located within walking distance of all homes, and a comprehensive system of walking and biking trails connects the homes to key destinations throughout Fanita Ranch.

A Special Use area is located in the southernmost portion of the Specific Plan Area, which was previously graded for a park and is not suitable for habitat preservation. The Special Use area allows for a limited range of uses, such as a solar farm, recreational vehicle storage and other uses appropriate to this area as stated in *Section 3.2.9: Special Use*. A mini-park serves as a trail staging area adjacent to the Special Use area.





**Exhibit 3.1: Land Use Plan**

**Table 3.1: Land Use Plan Statistical Summary**

Land Use Designation	Area (Acres) <sup>1</sup>	Dwelling Units <sup>2</sup>	Density Range (Du/Ac)	Commercial Square Feet <sup>2</sup>
<b>Residential &amp; Village Center</b>				
Low Density Residential (LDR)	240.8	1,203	4 - 10	N/A
Medium Density Residential (MDR)	67.0	866	8 - 25	
Active Adult (AA)	31.0	445	5 - 25	
Village Center (VC) <sup>3</sup>	36.5	435	Up to 50	60,000
<b>Residential &amp; Village Center Subtotal</b>	<b>375.3</b>	<b>2,949</b>		<b>60,000</b>
<b>Other Uses</b>				
Community Park (CP)	31.2	N/A	N/A	N/A
Neighborhood Park (NP)	30.4			
Mini-Park (MP) <sup>4</sup>	16.4			
School (S) Overlay	15.0			
Special Use (SU)	31.9			
Open Space (OS)	256.0			20,000
Agriculture (A) Overlay <sup>7</sup>	38.2			
Habitat Preserve (HP)	1,650.4			N/A
Roadways <sup>5</sup>	193.3			
<b>Other Uses Subtotal</b>	<b>2,262.8</b>			<b>20,000</b>
<b>SPECIFIC PLAN TOTAL</b>	<b>2,638.1</b>	<b>2,949<sup>6</sup></b>		<b>80,000</b>

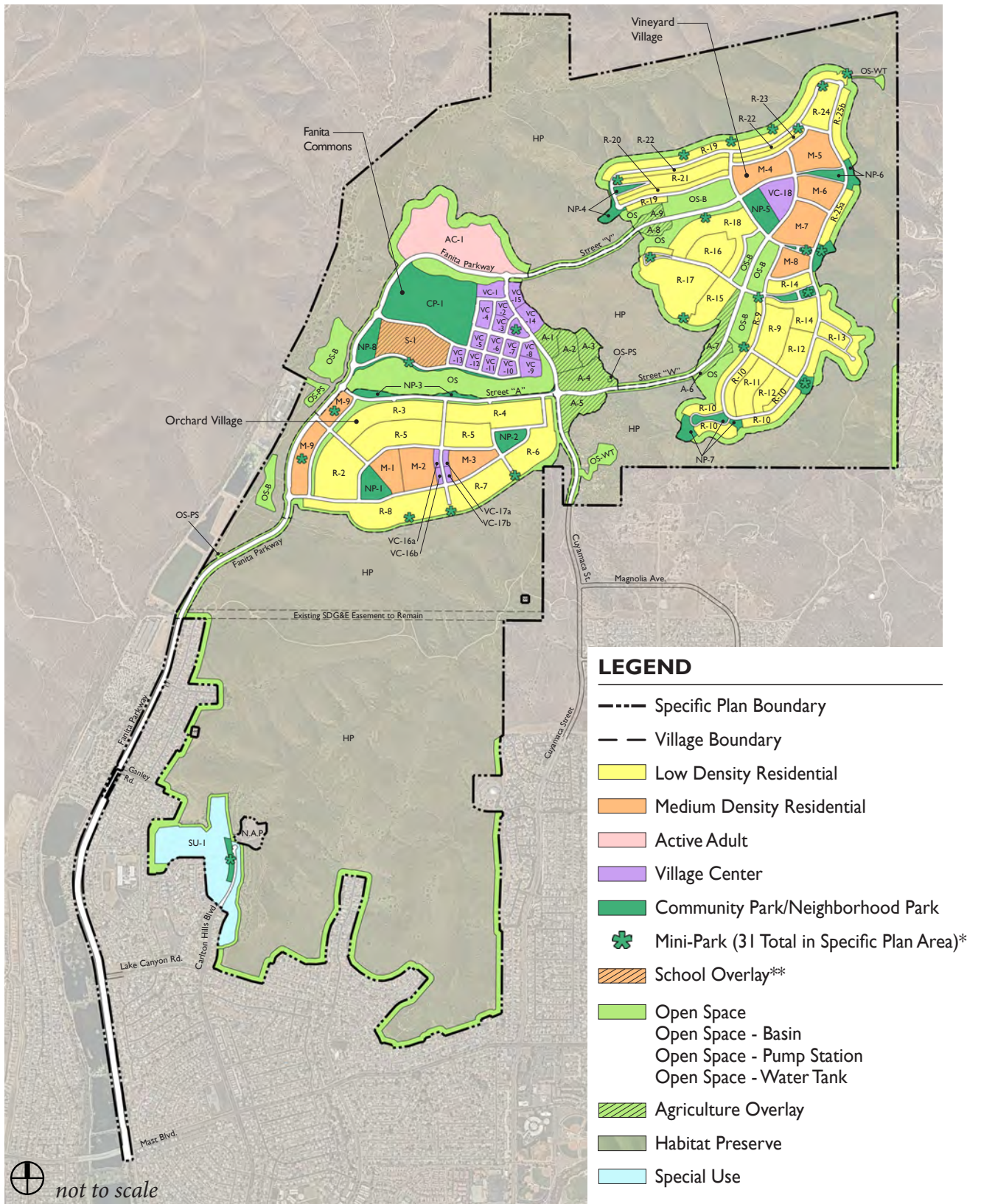
## Notes:

1. Acreage reflects the rounding of numbers to the 1/10th of an acre and may vary slightly from the calculated total.
2. The transfer of residential dwelling units and commercial square feet within the Specific Plan Area is permitted, subject to the provisions set forth in *Section 10.7.1: Administrative Amendments (Minor Modifications)*.
3. VC reserves a 1.5-acre fire station site.
4. There are 31 mini-parks on approximately 16.4 acres distributed throughout the Specific Plan Area, including the Village Green located in Fanita Commons.
5. Does not include approximately 28.6 acres of off-site roadway improvements.
6. The underlying land use for the S overlay site is MDR. If the reserved school site is not acquired for school use within 2 years of approval of the final map containing the S overlay site, the MDR land use may be implemented on the school site and the maximum total number of units in the Specific Plan Area shall be 3,008 units - see *Section 3.2.5: School (S) Overlay* and *Section 10.7.1: Administrative Amendments (Minor Modifications)*.
7. The underlying land use for the A overlay sites is OS. If an A overlay site is not developed with agricultural related uses described in *Section 3.2.8: Agriculture (A) Overlay*, the OS land use shall be implemented on the A overlay sites.

### 3.1.2 Site Utilization Plan

Fanita Ranch is planned to build out the planning areas shown in *Exhibit 3.2: Site Utilization Plan*. *Table 3.2: Site Utilization Plan Statistical Summary* provides information on the acreage, target number of dwelling units, target density and commercial square footage, as applicable, for each planning area within Fanita Ranch. The planning areas consist of individual residential and Village Center neighborhoods and non-residential areas within the Villages, as well as the Special Use, Open Space and Habitat Preserve areas outside the Villages. These planning areas correspond to the neighborhoods and lots in the Tentative Map prepared for Fanita Ranch. Due to market conditions and refinements in design and engineering, it is anticipated that minor statistical variations in the planning area configuration and size may occur as the land use plan is implemented. Dwelling units and commercial square footage may be transferred within the Specific Plan Area pursuant to *Section 10.7.1: Administrative Amendments (Minor Modifications)* of the Specific Plan.





\* There is a total of 8 mini-parks in M-9.

\*\* The underlying land use for the S overlay site is MDR. If the S overlay site is not acquired for school use within 2 years of approval of the final map containing the S overlay site, the MDR land use may be implemented on the S overlay site pursuant to Specific Plan Section 3.2.5: School (S) Overlay and Section 10.7.1: Administrative Amendments (Minor Modifications).

**Exhibit 3.2: Site Utilization Plan**

**Table 3.2: Site Utilization Plan Statistical Summary**

Planning Area <sup>2</sup>	Area (Acres) <sup>1</sup>	Target Dwelling Units <sup>2</sup>	Target Density (Du/Ac)	Commercial Square Feet <sup>2</sup>
<b>RESIDENTIAL</b>				
<b>LOW DENSITY RESIDENTIAL (LDR)</b>				
<b>Orchard Village</b>				
R-2	12.3	79	6	N/A
R-3	10.7	53	5	
R-4	11.3	56	5	
R-5	18.5	80	4	
R-6	9.1	53	6	
R-7	9.9	50	5	
R-8	16.8	83	5	
<i>LDR Subtotal - Orchard Village</i>	88.6	454		
<b>Vineyard Village</b>				
R-9	9.5	48	5	N/A
R-10	17.7	59	3	
R-11	6.0	33	6	
R-12	10.0	52	5	
R-13	12.8	43	3	
R-14	8.7	41	5	
R-15	6.4	26	4	
R-16	6.4	30	5	
R-17	15.8	52	3	
R-18	12.0	67	6	
R-19	16.2	67	4	
R-20	3.8	28	7	
R-21	6.8	70	10	
R-22	3.1	28	9	
R-23	2.4	20	8	
R-24	7.0	57	8	
R-25a	3.5	13	4	
R-25b	4.2	15	4	
<i>LDR Subtotal - Vineyard Village</i>	152.2	749		
<b>LOW DENSITY RES. TOTAL</b>	<b>240.8</b>	<b>1,203</b>		



**Table 3.2: Site Utilization Plan Statistical Summary (continued)**

Planning Area <sup>2</sup>	Area (Acres) <sup>1</sup>	Target Dwelling Units <sup>2</sup>	Target Density (Du/Ac)	Commercial Square Feet <sup>2</sup>
<b>RESIDENTIAL</b>				
<b>MEDIUM DENSITY RESIDENTIAL (MDR)</b>				
Orchard Village				
M-1	6.1	102	17	N/A
M-2	8.9	111	13	
M-3	6.5	79	12	
M-9	5.6	76	14	
<i>MDR Subtotal - Orchard Village</i>	<i>27.2</i>	<i>368</i>		
Vineyard Village				
M-4	8.5	106	13	N/A
M-5	9.4	117	13	
M-6	6.8	85	13	
M-7	10.3	129	13	
M-8	4.9	61	13	
<i>MDR Subtotal - Vineyard Village</i>	<i>39.8</i>	<i>498</i>		
<b>MED. DENSITY RES. TOTAL</b>	<b>67.0</b>	<b>866</b>		
<b>ACTIVE ADULT (AA)</b>				
Fanita Commons				
AC-1	31.0	445	14	N/A
<b>ACTIVE ADULT TOTAL</b>	<b>31.0</b>	<b>445</b>		

**Table 3.2: Site Utilization Plan Statistical Summary (continued)**

Planning Area <sup>2</sup>	Area (Acres) <sup>1</sup>	Target Dwelling Units <sup>2</sup>	Target Density (Du/Ac)	Commercial Square Feet <sup>2</sup>
<b>VILLAGE CENTER</b>				
<b>VILLAGE CENTER (VC)</b>				
<b>Fanita Commons</b>				
VC-1	2.6	323	Up to 50	40,000
VC-2 <sup>3</sup>	1.5			
VC-3	1.4			
VC-4	2.4			
VC-5	1.5			
VC-6	1.5			
VC-7	1.5			
VC-8	1.7			
VC-9	2.7			
VC-10	1.7			
VC-11	1.5			
VC-12	1.5			
VC-13	1.6			
VC-14	2.8			
VC-15	1.9			
<i>VC Subtotal - Fanita Commons</i>	<i>27.7</i>	<i>323</i>		<i>40,000</i>
<b>Orchard Village</b>				
VC-16a	0.7	33	Up to 50	10,000
VC-16b	0.7			
VC-17a	0.6			
VC-17b	0.6			
<i>VC Subtotal - Orchard Village</i>	<i>2.6</i>	<i>33</i>		<i>10,000</i>
<b>Vineyard Village</b>				
VC-18	6.1	79	Up to 50	10,000
<i>VC Subtotal - Vineyard Village</i>	<i>6.1</i>	<i>79</i>		<i>10,000</i>
<b>VILLAGE CENTER TOTAL</b>	<b>36.5</b>	<b>435</b>		<b>60,000</b>
<b>RESIDENTIAL &amp; VILLAGE CENTER TOTAL</b>	<b>375.3</b>	<b>2,949</b>		<b>60,000</b>

**Table 3.2: Site Utilization Plan Statistical Summary (continued)**

Planning Area <sup>2</sup>	Area (Acres) <sup>1</sup>	Target Dwelling Units <sup>2</sup>	Commercial Square Feet <sup>2</sup>
<b>OTHER USES</b>			
<b>PARKS</b>			
<b>COMMUNITY PARK (CP)</b>			
CP-1 (Active)	19.7	N/A	N/A
CP-1 (Passive)	11.5		
<b>CP Total</b>	<b>31.2</b>		
<b>NEIGHBORHOOD PARK (NP)</b>			
NP-1	4.6	N/A	N/A
NP-2	3.3		
NP-3	3.2		
NP-4	2.6		
NP-5	5.3		
NP-6	3.4		
NP-7	3.8		
NP-8	4.2		
<b>NP Total</b>	<b>30.4</b>		
<b>MINI-PARK (MP)</b>			
All MPs <sup>4</sup>	16.4	N/A	N/A
<b>MP Total</b>	<b>16.4</b>		
<b>PARK TOTAL</b>	<b>78.0</b>		
<b>SCHOOL (S) OVERLAY<sup>6</sup></b>			
S-1 (School)	15.0	0	N/A
<b>SCHOOL OVERLAY TOTAL</b>	<b>15.0</b>		
<b>SPECIAL USE (SU)</b>			
SU-1	31.9	0	N/A
<b>SPECIAL USE TOTAL</b>	<b>31.9</b>		
<b>OPEN SPACE (OS)</b>			
OS (Open Space)	210.7	N/A	N/A
OS-B (Open Space - Basin)	37.8		
OS-PS (Open Space - Pump Station)	2.5		
OS-WT (Open Space - Water Tank)	5.0		
<b>OPEN SPACE TOTAL</b>	<b>256.0</b>		

**Table 3.2: Site Utilization Plan Statistical Summary (continued)**

Planning Area <sup>2</sup>	Area (Acres) <sup>1</sup>	Target Dwelling Units <sup>2</sup>	Commercial Square Feet <sup>2</sup>
<b>OTHER USES</b>			
<b>AGRICULTURE (A) OVERLAY<sup>7</sup></b>			
Fanita Commons			
A-1	3.4	0	20,000
A-2	5.7		
A-3	3.8		
A-4	8.2		
A-5	6.3		
<i>A Overlay Subtotal - Fanita Commons</i>	<i>27.3</i>		<i>20,000</i>
Vineyard Village			
A-6	1.8	0	0
A-7	5.3		
A-8	2.0		
A-9	1.8		
<i>A Overlay Subtotal - Vineyard Village</i>	<i>10.9</i>		<i>0</i>
<b>AGRICULTURE OVERLAY TOTAL</b>	<b>38.2</b>		<b>20,000</b>
<b>HABITAT PRESERVE (HP)</b>			
HP	1,650.4	N/A	N/A
<b>HABITAT PRESERVE TOTAL</b>	<b>1,650.4</b>		
<b>ROADWAYS</b>			
Major Roadways	56.4	N/A	N/A
Neighborhood Roadways	136.8		
<b>ROADWAY TOTAL<sup>5</sup></b>	<b>193.3</b>		
<b>OTHER USES TOTAL</b>	<b>2,262.8</b>		<b>20,000</b>
<b>SPECIFIC PLAN TOTAL</b>	<b>2,638.1</b>	<b>2,949<sup>6</sup></b>	<b>80,000</b>

Notes:

1. Acreage reflects the rounding of numbers to the 1/10th of an acre and may vary slightly from the calculated total.
2. The planning areas in the Site Utilization Plan correspond to the neighborhoods and lots in the Tentative Map for Fanita Ranch. The transfer of residential dwelling units and commercial square feet within the Specific Plan Area is permitted, subject to the provisions set forth in *Section 10.7.1: Administrative Amendments (Minor Modifications)*.
3. VC-2 reserves a 1.5-acre fire station site.
4. There are 31 mini-parks on approximately 16.4 acres distributed throughout the Specific Plan Area, including the Village Green located in Fanita Commons.
5. Does not include approximately 28.6 acres of off-site roadway improvements.
6. The underlying land use for the S-1 planning area is MDR. If the reserved school site is not acquired for school use within 2 years of approval of the final map containing the S-1 planning area, the MDR land use may be implemented on the S-1 planning area and the maximum total number of units in the Specific Plan Area shall be 3,008 units - see *Section 3.2.5: School (S) Overlay* and *Section 10.7.1: Administrative Amendments (Minor Modifications)*.
7. The underlying land use for the A overlay planning areas is OS. If an A overlay planning area is not developed with agricultural related uses described in *Section 3.2.8: Agriculture (A) Overlay*, the OS land use shall be implemented on the A overlay planning areas.

## 3.2 Land Use Designations and Development Regulations

The following sections provide a description, a list of permitted uses and development regulations for each land use designation within the Specific Plan Area. Permitted uses are intended to provide flexibility to encourage creativity, diversity and innovation that support the sustainable and agrarian community concept. As such, land uses that are similar in character to another use permitted by the Specific Plan are allowed. Similarly, the development regulations seek to support sustainability and wellness as key themes for the community and are therefore tailored to the unique vision for Fanita Ranch.

Development standards provide the minimum and/or maximum standards for building setbacks, heights, lot coverage and more. Buildings should not always be designed to maximum height and minimum setback standards; instead, setbacks, heights and massing should be varied to avoid monotonous repetition and rhythms along the streets. In the Village Center, Medium Density Residential and Active Adult land use designation areas, no minimum standards are set for the lot areas, depths and widths to promote maximum flexibility in building design, placement and innovation. Design and construction of all buildings within the Specific Plan Area shall comply with the California Building Code and Fire Code, which may be amended from time to time. These standards are intended to work together with the community design, landscape and architectural design guidelines provided in *Chapter 5: Landscape Architecture, Community Design & Outdoor Lighting Design Plan* and *Chapter 6: Architectural Design Guidelines* to create eclectic and visually interesting neighborhoods that each maintain their own identities. The appropriate building typologies for each land use designation are identified herein and described in greater detail in *Chapter 6: Architectural Design Guidelines*.

### 3.2.1 Village Center (VC)

#### A. Description

The Village Center land use designation allows for a mix of residential, commercial, civic and recreational uses in a walkable mixed-use configuration. Residential densities range up to 50 du/ac. When uses are mixed, they may be combined horizontally (side-by-side or adjacent to one another) or vertically (residential or office above retail). There are three Village Centers within Fanita Ranch. The largest is located in Fanita Commons and is intended to serve the entire Specific Plan Area. Two smaller Village Centers are located in the Orchard Village and Vineyard Village, which are intended to provide for similar mixed-use residential, retail, service, office and/or recreational needs of those individual Villages.

#### B. Permitted Uses

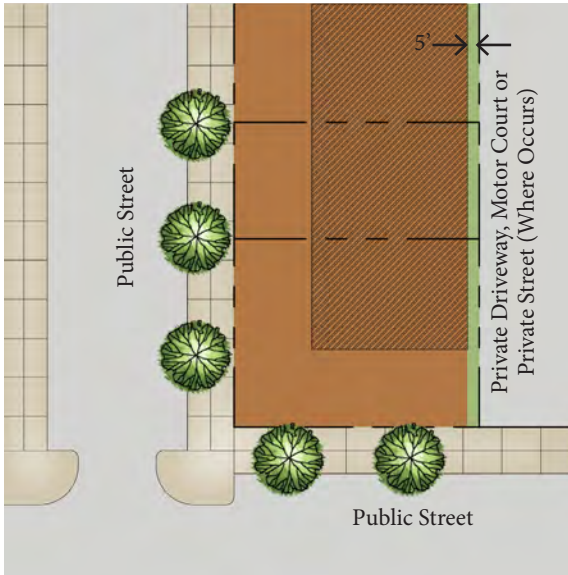
Permitted Uses in VC Land Use Designation Areas
<b>Food and Beverage Sales or Service</b>
Farmer’s market, farm stands and food halls
Groceries, specialty food markets and corner markets (including sale of alcohol for off-site consumption) <sup>1</sup>
Live entertainment or dancing - including nightclubs, dance halls, restaurants, social clubs, lodges and similar uses <sup>1</sup>
With alcohol sales and service - restaurants, breweries, cocktail lounges, bars, tasting rooms and similar uses <sup>1</sup>
Without alcohol - including delicatessens, bakeries, cafes, restaurants and similar uses
<b>Retail Sales and Services, Office</b>
Business services - photocopying, mail services and similar uses
Commercial recreation, indoor - bowling lanes, theaters, billiards, arcades and similar uses
Commercial recreation, outdoor - including mazes, kiddie rides, pony rides, petting zoos and similar uses <sup>2</sup>
Financial services and institutions
Garden center nursery
Health/athletic clubs and studios - yoga, dance, martial arts and similar uses
Health and wellness spas and services such as chiropractic, acupuncture and similar uses
Kiosks and carts for general retail and food sales
Minor auto repairs, car wash and gasoline station <sup>3</sup>
Lodging - hotels, motels, inns, farm-stays and similar uses
Offices - administrative, executive offices, medical, dental, co-working space, and other non-profit and professional offices
Personal care - barber and beauty shops, manicure/pedicure shops, health and wellness spas, tanning salons, massage establishments <sup>5</sup> and similar uses
Personal services - drug stores, pharmacies, dry cleaners (off-site processing only), laundry, shoe repair, tailor, automated teller machines and similar uses
Retail - stores that sell goods and merchandise
Studios and galleries - art, music, photography and similar uses
Veterinary, grooming, daycare and other pet service

Permitted Uses in VC Land Use Designation Areas
<b>Residential</b>
Congregate care facilities
Cooperative community
Home occupation
Live-work
Multi family residential
Single family residential
<b>Public and Quasi-Public Uses</b>
Assembly halls, wedding chapels, religious and spiritual assembly space and similar uses <sup>2</sup>
Business school, trade school, private school
Commercial kitchens, amphitheaters and similar facilities associated with farm education and promotion <sup>2</sup>
Civic uses such as a fire station, law enforcement satellite office, post office and other public buildings
Museums, nature centers, or similar cultural and public education uses <sup>2</sup>
Day care, small family
Day care, large family; child care center
Elementary, middle and high school (public, charter or private)
Professionally managed community gardens and community supported agriculture
Private community recreation facilities including, but not limited to, clubhouses, pool facilities and similar uses
Tutoring center
<b>Other Uses</b>
Accessory uses typically associated with a primary use
HOA maintenance/storage
Parking lots, park & ride lots and structures
Temporary uses such as festivals, carnivals, model homes and sales offices and similar uses <sup>4</sup>
Water quality features including swales, basins, bio-retention areas and other BMPs

1. See *Section 3.2.11.10 (B): Sale of Alcohol* for applicable regulations.
2. See *Section 3.2.11.10 (C): Places of Worship or Assembly* for applicable regulations.
3. Gasoline stations shall be limited to an outflow of 3.6 million gallons of fuel per year.
4. Temporary uses shall be subject to the applicable criteria and conditions of Santee Municipal Code (SMC) Section 13.06.070.
5. Massage establishments shall be subject to the applicable criteria and requirements of SMC Chapter 4.17, Massage.



**C. Development Standards**



Legend

- Primary Building
- Garage (Where Occurs)

**Lot Standards<sup>1</sup>**

Min. Net Lot Area	None
Density Range (du/gross acre)	Up to 50
Minimum Lot Depth	None
Minimum Lot Width	None
Maximum Lot Coverage	90%
Maximum Height <sup>2</sup>	55 feet (4 Stories)

**Minimum Setbacks & Separations<sup>2</sup>**

Building Separation	0 feet
Primary Building to Public Street Right-of-Way	0 feet
Garage to Private Driveway, Motor Court or Private Street (Where Occurs)	5 feet
Building to Interior Property Line	0 feet

**D. Appropriate Building Typologies**

- Detached Cluster Homes
- Attached/Semi-Detached Homes
- Attached Buildings
- Community Buildings

1. Where development standards are not provided herein, those standards will be determined at the Development Review stage. Individual planning areas shown within a Village Center shown in *Exhibit 3.2: Site Utilization Plan* and *Table 3.2: Site Utilization Plan Statistical Summary* may be combined and/or reconfigured during the Development Review stage, as described in *Section 10.6.5: Development Review*.
2. See *Section 3.2.11.1* for projection, encroachment and height exceptions.



The Village Center designation allows for a mix of retail, office and/or higher density residential uses. Stoops and storefront windows should be designed and oriented to define and engage the sidewalk to create a walkable, pedestrian oriented-district. Outdoor seating adds activity to the street contributing to a positive pedestrian experience.

## E. Parking

Vehicle parking shall be provided in accordance with SMC Section 13.24.040, Parking Requirements, unless otherwise stated herein. The Village Center land use designation allows for shared vehicle parking between uses as a means of reducing large parking lots and pavement areas that contribute to heat island effect. Shared parking agreements shall comply with the provisions in *Section 3.2.10.9: Parking* of the Specific Plan. Shared parking shall be managed pursuant to the Transportation Demand Management (TDM) Plan's shared parking requirements (See *Section 4.1.8: Transportation Demand Management*). Each Village Center shall also provide electric vehicle (EV) charging stations and preferred parking per CALGreen requirements, and designated passenger loading areas to encourage alternative fuel vehicle use and car sharing. On-street parking may be counted toward fulfilling the required number of on-site parking spaces.

Bicycle parking is required as specified by CALGreen. In addition, each Village Center shall provide a bike station. The bike station may include access to air and water, a bike share and/or charging stations for electric bicycles.

Minimum Number of Required Vehicle Spaces by Use	
Use	Spaces Required
Residential	
Studio & 1 bedroom	1 per unit (1 enclosed)
2 or more bedroom	2 per unit (1 enclosed)
Resident Guest	0.1 per unit
Congregate Care	Per Parking Study
Lodging	1 per key + 2 spaces
Automobile Service and Gas Station	3 spaces + 2 per service bay
Daycare (not accessory to another use)	1 per staff member + 1 per 5 children
Restaurants <sup>1</sup>	1 per 100 SF of seating area
Churches and Other Places of Assembly	1 per 100 SF of principal assembly space
Museums and Galleries	1 per 500 SF of gross floor area
Retail (Orchard Village and Vineyard Village)	1 per 250 SF of gross floor area
Retail (Fanita Commons)	1 per 400 SF of gross floor area

1. Outdoor seating may be provided up to 25% of the interior seating area without additional parking required.
2. Uses not listed shall provide parking in accordance with the SMC or pursuant to a City approved TDM Plan.

## F. Open Space

1. A minimum of 60 square feet per residential dwelling unit of private open space shall be provided. Private open space may be in the form of side and rear yards, patios, porches, decks and/or balconies.
2. The minimum dimension of any ground-floor private open space shall be 5 feet.
3. The minimum dimension of any above-ground private open space shall be 4 feet.



### 3.2.2 Medium Density Residential (MDR)

#### A. Description

The Medium Density Residential (MDR) land use designation establishes areas for residential uses in a variety of attached, detached and semi-detached building typologies, at densities ranging from 8 to 25 du/ac. The MDR land use designation occurs in the Orchard Village and Vineyard Village near parks and the Village Centers to promote walkability. Homes may be served by public or private streets along the front, private driveways at the rear or in motor courts.



*The Medium Density Residential designation allows for a wide variety of attached and detached building typologies, providing diverse housing choices for a range of income levels, household types and lifestyles.*

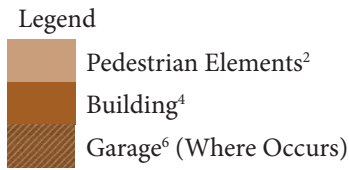
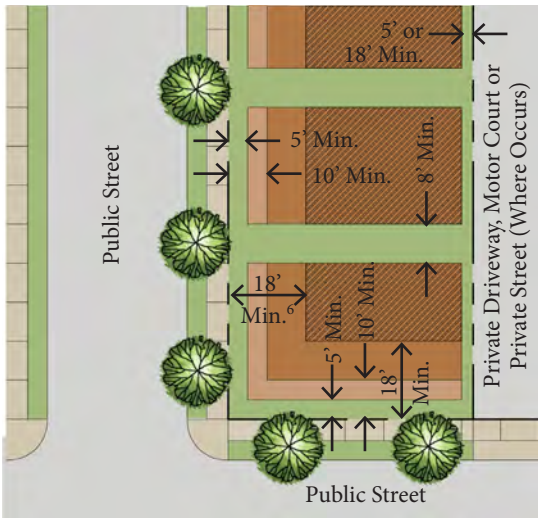
**B. Permitted Uses**

Permitted Uses in MDR Land Use Designation Areas
<b>Residential</b>
Cooperative community
Home occupation
Live-work
Multi-family residential
Single family residential
Age-restricted residential
<b>Public and Quasi-Public Uses</b>
Day care, small family
Day care, large family <sup>1</sup>
Elementary, middle and high school (public, charter or private)
Professionally managed community gardens and community supported agricultural uses
Private community recreation facilities including, but not limited to, clubhouses, pool facilities and similar uses
<b>Other Uses</b>
Accessory uses typically associated with a primary use including, but not limited to, rental offices
HOA maintenance/storage
Temporary uses for model homes, sales offices and similar uses <sup>2</sup>
Water quality features including swales, basins, bio-retention areas and other BMPs

1. Large family day care shall comply with the regulations of SMC Section 13.30.020(H).

2. Temporary uses shall be subject to the applicable criteria and conditions of SMC Section 13.06.070.

**C. Development Standards**



**D. Appropriate Building Typologies**

- Single Family Detached Homes<sup>7</sup>
- Detached Cluster Homes
- Attached/Semi-Detached Homes
- Community Buildings

Lot Standards <sup>1</sup>	
Min. Net Lot Area	None
Density Range (du/gross acre)	8-25
Minimum Lot Depth	None
Minimum Lot Width	None
Maximum Lot Coverage	75%
Maximum Height <sup>5</sup>	45 feet (3-4 Stories) <sup>3</sup>
Minimum Setbacks & Separations <sup>5</sup>	
Building Separation	0 <sup>4</sup> or 8 feet
Primary Building to Public Street Right-of-Way	10 feet
Pedestrian Elements <sup>4</sup> to Public Street Right-of-Way	5 feet
Front-Entry Garage Face to Public Street Right-of-Way	18 feet
Side-Entry Garage to Public Street Right-of-Way <sup>6</sup>	10 feet
Garage to Private Driveway, Motor Court or Private Street (Where Occurs)	5 feet or ≥18 feet

1. Where development standards are not provided herein, those standards will be determined at the Development Review stage.
2. Pedestrian elements include porches, courtyards, patios, stoops, arcades and single story projections that express the architectural style of the building and add human scale.
3. Only attached residential homes may be 4 stories tall and have a maximum height of 55 feet. Variations in massing and height of 4-story buildings are strongly encouraged.
4. Buildings may be fee simple, semi-detached buildings that are joined together by a sheet metal cap at the roof level but are structurally independent, with separate foundations and an airspace of approximately 4 to 8 inches between units. See the row home example in *Section 6.2.3: Attached/Semi Detached Home*.
5. See *Section 3.2.11.1* for projection, encroachment and height exceptions.
6. Side-entry garages shall be limited to lots 55 feet or wider to allow for adequate back-up space.
7. Refer to the diagram in *Section 3.2.3.C: Low Density Residential Development Standards* for front-loaded single-family detached homes.

## E. Parking

Vehicle parking for the MDR land use designation shall be provided in accordance with SMC Section 13.24.040, Parking Requirements, unless otherwise stated herein. Parking should reflect the anticipated household demographic, consider proximity to the Village Center and parks, and seek to promote walkability or alternative modes to single occupancy vehicle use. Off-street parking should be distributed throughout the attached residential development sites to ensure proximity to the units being served and avoid large parking areas. On-street parking may be counted toward fulfilling the required number of guest parking spaces for detached cluster homes and attached/semi-detached homes.

Minimum Number of Required Vehicle Spaces by Use	
Use	Spaces Required
Residential - Detached Cluster Homes and Attached/Semi-Detached Homes	
Studio & 1 bedroom units	1 per unit (enclosed)
2 or more bedroom units	2 per unit (1 enclosed)
Resident Guest <sup>1</sup>	0.25 per unit

1. Guest parking is required for dwellings that do not have full garage driveways. On-street parking may be counted toward meeting the guest parking space requirements.

Bicycle parking is required to encourage bicycling as an alternative to motor vehicle use. Bicycle parking for attached residential development shall be provided as specified by CALGreen.

## F. Open Space

1. A minimum of 100 square feet per residential dwelling unit of private open space shall be provided. Private open space may be in the form of side and rear yards, patios, courtyards, California Rooms, porches, decks and/or balconies.
2. The minimum dimension of any ground-floor private open space shall be 5 feet.
3. The minimum dimension of any above-ground private open space shall be 4 feet.
4. A minimum of 50 square feet per residential dwelling unit of common open space shall be provided for attached residential development.



### 3.2.3 Low Density Residential (LDR)

#### A. Description

The Low Density Residential (LDR) land use designation establishes areas for low density detached residential uses in a variety of lot sizes and configurations, with densities ranging from 4 to 10 du/ac. The Low Density Residential land use designation occurs in Orchard Village and Vineyard Village near parks and trailheads to promote walkability and wellness.



*The Low Density Residential designation allows for a wide range of housing sizes, providing homeownership opportunities for a range of income levels, household types and lifestyles.*

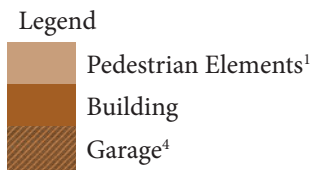
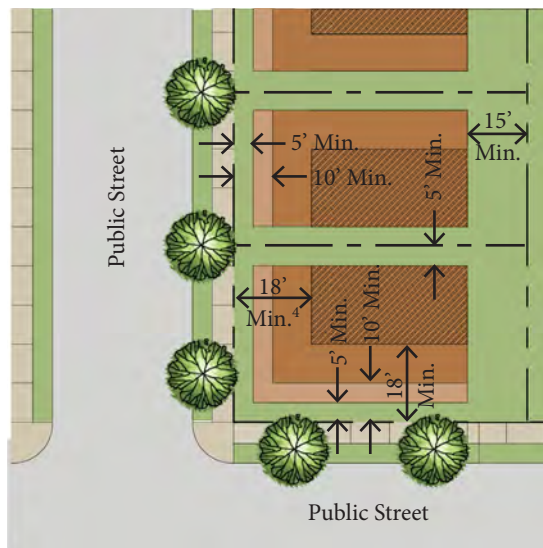
**B. Permitted Uses**

Permitted Uses in LDR Land Use Designation Areas
<b>Residential</b>
Cooperative community
Home occupation
Live-work
Single family residential
<b>Public and Quasi-Public Uses</b>
Day care, small family
Day care, large family <sup>1</sup>
Professionally managed community gardens and community supported agriculture
Private community recreation facilities including, but not limited to, clubhouses, pool facilities and similar uses
<b>Other Uses</b>
Accessory uses typically associated with a primary use including, but not limited to, accessory dwelling units
HOA maintenance/storage
Temporary uses for model homes, sales offices and similar uses <sup>2</sup>
Water quality features including swales, basins, bio-retention areas and other BMPs

1. Large family day care shall comply with the regulations of SMC Section 13.30.020(H).

2. Temporary uses shall be subject to the applicable criteria and conditions of SMC Section 13.06.070.

**C. Development Standards**



**D. Appropriate Building Typologies**

- Single Family Detached Homes<sup>5</sup>
- Detached Cluster Homes<sup>5</sup>
- Community Buildings

Lot Standards	
Min. Net Lot Area	3,750 SF
Density Range (du/gross acre)	4-10
Minimum Lot Depth	75 feet
Minimum Lot Width	50 feet
Maximum Lot Coverage	60%
Maximum Height <sup>3</sup>	45 feet (3 Stories) <sup>2</sup>
Minimum Setbacks & Separations <sup>3</sup>	
Building Separation	10 feet
Building to Public Street Right-of-Way <sup>6</sup>	10 feet
Pedestrian Elements <sup>2</sup> to Public Street Right-of-Way	5 feet
Front-Entry Garage Face to Public Street Right-of-Way	18 feet
Side-Entry Garage to Public Street Right-of-Way <sup>4</sup>	10 feet
Garage to Private Driveway, Motor Court or Private Street (Where Occurs)	5 feet or ≥18 feet
Building to Interior Side Property Line	5 feet
Building to Rear Property Line Not Abutting an Open Space Land Use Designation Area	15 feet
Building to Rear or Side Property Line Located at Edge of a Building Pad Abutting an Open Space Land Use Designation Area	15 feet
Building to Rear or Side Property Line Located on a Slope Abutting Open Space Land Use Designation Area	65 feet <sup>7</sup>

1. Pedestrian elements include porches, courtyards, patios, stoops, arcades and single story projections that express the architectural style of the building and add human scale.
2. Where provided, the third-floor square footage shall not exceed 80% of the second-floor square footage. Three-story buildings may not be located on corner lots.
3. See *Section 3.2.11.1* for projection, encroachment and height exceptions.
4. Side-entry garages shall be limited to lots 55 feet or wider to allow for adequate back-up space.
5. Refer to the diagram in *Section 3.2.2.C* for rear-loaded single-family and detached cluster homes.
6. Additional front setbacks may be needed to accommodate retaining walls located in the front yards.
7. 50 feet of the rear or side setback is defined as FMZ 1B (where required) and FMZ 1C in the Fanita Ranch FPP.

**F. Parking**

Vehicle parking shall be provided in accordance with SMC Section 13.24.040, Parking Requirements. A minimum of 2 enclosed spaces per residential unit are required within the Low Density Residential neighborhoods, consistent with City's single family parking requirements. Guests parking may be provided on-street or off-street. Bicycle parking can occur in garages or privately fenced setback areas.

**G. Open Space**

1. A minimum of 350 square feet per dwelling unit of private open space shall be provided. Private open space may be in the form of side and rear yards, patios, courtyards, California Rooms, porches, decks and/or balconies.
2. The minimum dimension of any ground-floor private open space shall be 5 feet.
3. The minimum dimension of any above-ground private open space shall be 4 feet.



### 3.2.4 Active Adult (AA)

#### A. Description

The Active Adult land use designation establishes areas for age-restricted residential uses in a variety of building typologies, with densities ranging from 5 to 25 du/ac. The Active Adult land use designation occurs in Fanita Commons near the Village Center, Farm and Community Park to promote walkability.



*The Active Adult designation allows for a wide variety of attached and detached building typologies, providing housing opportunities for a range of income levels and lifestyles.*

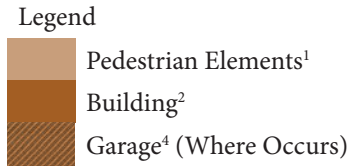
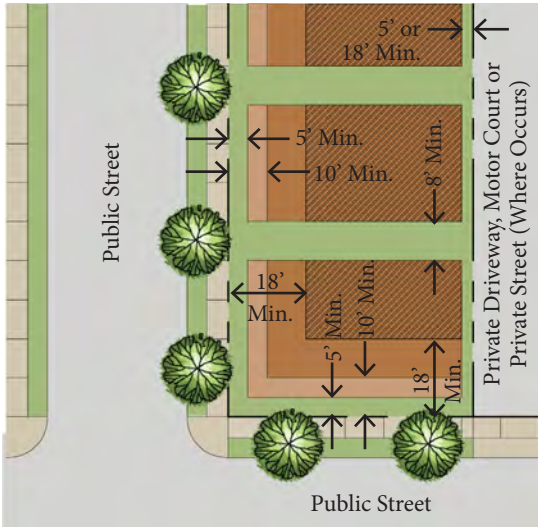
**B. Permitted Uses**

Permitted Uses in AA Land Use Designation Areas
<b>Residential</b>
Cooperative community
Home occupation
Live-work
Multi family residential
Single family residential
<b>Public and Quasi-Public Uses</b>
Professionally managed community gardens and community supported agriculture
Private community recreation facilities including, but not limited to, clubhouses, pool facilities and similar uses
<b>Other Uses</b>
Accessory uses typically associated with a primary use including, but not limited to, rental offices
HOA maintenance/storage
Temporary uses for model homes, sales offices and similar uses <sup>1</sup>
Water quality features including swales, basins, bio-retention areas and other BMPs

1. Temporary uses shall be subject to the applicable criteria and conditions of SMC Section 13.06.070.



**C. Development Standards**



**D. Appropriate Building Typologies**

- Single Family Detached Homes<sup>5</sup>
- Detached Cluster Homes
- Attached/Semi-Detached Homes
- Community Buildings

Lot Standards <sup>7</sup>	
Min. Net Lot Area	None
Density Range (du/gross acre)	5-25
Minimum Lot Depth	None
Minimum Lot Width	None
Maximum Lot Coverage	75%
Maximum Height <sup>3</sup>	55 feet (4 Stories)
Minimum Setbacks & Separations <sup>3</sup>	
Building Separation	0 <sup>2</sup> or 8 feet
Primary Building to Public Street Right-of-Way	10 feet
Pedestrian Elements <sup>1</sup> to Public Street Right-of-Way	5 feet
Garage Face to Public Street Right-of-Way	18 feet
Side-Entry Garage to Public Street Right-of-Way <sup>4</sup>	10 feet
Garage to Private Driveway, Motor Court or Private Street (Where Occurs)	5 feet or ≥18 feet
Building to Rear Property Line Not Abutting an Open Space Land Use Designation Area	15 feet
Building to Rear or Side Property Line Located at Edge of a Building Pad Abutting an Open Space Land Use Designation Area	15 feet
Building to Rear or Side Property Line Located on a Slope Abutting an Open Space Land Use Designation Area	65 feet <sup>6</sup>

1. Pedestrian elements include porches, courtyards, patios, stoops, arcades and single story projections that express the architectural style of the building and add human scale.
2. Buildings may be fee simple, semi-detached units that are joined together by a sheet metal cap at the roof level but are structurally independent, with separate foundations and an airspace of approximately 4 to 8 inches between units. See the row home example in *Section 6.2.3: Attached/Semi-Detached Homes*.
3. See *Section 3.2.11.1* for projection, encroachment and height exceptions.
4. Side-entry garages shall be limited to lots 55' or wider to allow for adequate back-up space.
5. Refer to the diagram in *Section 3.2.3.C* for front-loaded single-family detached homes.
6. 50 feet of the rear or side setback is defined as FMZ 1B (where required) and FMZ 1C in the Fanita Ranch FPP.
7. Where development standards are not provided herein, those standards will be determined at the Development Review stage.

## E. Parking

Vehicle parking requirements for the Active Adult land use designation shall be provided in accordance with SMC Section 13.24.040, Parking Requirements, unless otherwise stated herein. Parking should reflect the anticipated household demographic, consider proximity to the Village Center and the Farm, and seek to promote walkability or alternative modes to single occupancy vehicle use. On-street parking may be counted toward fulfilling the required number of guest parking spaces for detached cluster homes and attached/semi-detached homes.

Minimum Number of Required Vehicle Spaces by Use	
Use	Spaces Required
Residential - Detached Cluster Homes and Attached/Semi-Detached Homes	
Studio & 1 bedroom units	1 per unit (enclosed)
2 or more bedroom units	2 per unit (1 enclosed)
Resident Guest <sup>1</sup>	0.25 per unit

1. Guest parking is required for dwellings that do not have full garage driveways. On-street parking may be counted toward meeting the guest parking space requirements.

Bicycle parking is required to encourage bicycling as an alternative to motor vehicle use. Bicycle parking shall be provided as specified by CALGreen.

## F. Open Space

1. A minimum of 60 square feet per dwelling unit of private open space shall be provided. Private open space may be in the form of side and rear yards, patios, courtyards, California Rooms, porches, decks and/or balconies.
2. The minimum dimension of any ground-floor private open space shall be 5 feet.
3. The minimum dimension of any above-ground private open space shall be 4 feet.
4. A minimum of 50 square feet per residential dwelling unit of common open space shall be provided for attached residential development.

### 3.2.5 School (S) Overlay

#### A. Description

The School (S) overlay reserves a site for a potential K-8 public school or other educational uses. If acquired by the Santee School District, the site can accommodate up to 700 students, including existing Santee students and new students within Fanita Ranch.

#### B. Permitted Uses

Permitted Uses in S Overlay Area
<b>Public and Quasi-Public Uses</b>
Public schools
Charter schools
Private schools
Child care center
Nature centers, cultural and farm education facilities
<b>Other Uses</b>
Temporary uses such as festivals, carnivals, and similar uses <sup>1</sup>
Water quality features including swales, basins, bio-retention areas and other BMPs

1. Temporary uses shall be subject to the applicable criteria and conditions of SMC Section 13.06.070.

#### C. Alternative Residential Uses

The community vision for Fanita Ranch includes a K-8 school site in Fanita Commons. The underlying land use for the S overlay site is MDR. In the event that the school site (S-1 planning area shown in *Exhibit 3.2: Site Utilization Plan*) is not acquired for a public or private school use within two years of filing of the final map for the phase in which the site is located, the underlying MDR land use designation may be implemented and the maximum total number of units permitted in the Specific Plan Area shall be 3,008 units. The additional 59 MDR units have been analyzed in the EIR, and additional units may be transferred from other residential or Village Center planning areas within Fanita Ranch to this site to achieve the required MDR density, subject to the density transfer requirements set forth in *Section 10.7.1: Administrative Amendments (Minor Modifications)*.

#### D. Parking

Parking for vehicles and bicycles in the School overlay area shall be provided per SMC Section 13.24.040.

### 3.2.6 Parks (CP, NP and MP)

#### A. Description

The park designations include Community Parks (CP), Neighborhood Parks (NP) and Mini-Parks (MP) that are distributed throughout the community to provide active and passive recreational opportunities and gathering spaces within walking distance of all homes. Some of the MP designated areas also provide trail access and serve as the primary access point to the trail system in the Habitat Preserve and Open Space land use designation areas. *Chapter 7: Parks, Recreation & Open Space* includes a detailed description, design criteria and a list of anticipated uses for each type of park.

#### B. Permitted Uses

Permitted Uses in CP, NP and MP Land Use Designation Areas <sup>1</sup>
Agriculture including orchards, vineyards, crops
Play structures, play equipment and similar uses typically associated with parks
Cultural and historic monument, public art
Gardens - Community, children's, educational, demonstration, therapy, botanical and similar uses
Community buildings, swimming pools, play fields, sport courts, community aquatic recreation facilities and other recreational uses typically associated with a park and recreational uses as appropriate to the size and scale of the park (See <i>Chapter 7: Parks Recreation &amp; Open Space</i> )
Interpretive signage, trail markers, building identification and other wayfinding and educational signage
Kiosks, benches, shade structures, bike repair stations and similar park amenities
Paseos
Public utilities, associated rights-of way and grading (including photo voltaic)
Restrooms
Trailheads
Walking and biking trails (no equestrian)
Water quality features including swales, basins, bio-retention areas and other BMPs

1. Permitted uses listed above may be expanded based on park plans approved by the City of Santee. Public parks shall be subject to the approval of Conditional Use Permits pursuant to the procedures set forth in SMC Section 13.06.030.

#### C. Permitted Building Typologies

- Community Buildings

**D. Parking Requirements**

Vehicle parking for the Community Park and public neighborhood park (see CP-1 and NP-8 on *Exhibit 3.2, Site Utilization Plan*) shall be provided in accordance with the parking ratios listed herein, Americans with Disabilities Act and California Building Code Title 24 regulations. Parking may be provided by on-site parking facilities, on adjacent streets or a combination thereof. Parking may be shared with the adjacent K-8 school site, subject to a shared parking agreement.

Private neighborhood parks and mini-parks are intended to serve residents who live within walking distance of the parks. The parking needs for private parks will be met through on-street parking on adjacent streets (except as necessary to accommodate accessible and EV parking).

Bicycle parking and EV charging spaces shall be provided as specified by CALGreen.

Minimum Number of Required Vehicle Spaces by Use	
Use	Spaces Required
Community Park and Public Neighborhood Park	
Non-programmed Park Land <sup>1</sup>	5 per acre
Multi-purpose Fields	30 per backstop
Community Center/ Recreation Center	1 per 200 SF of gross floor area
Tennis Courts and Basketball Courts	12 per 6 courts; none if less than 6 courts
Swimming Pool	1 per 175 SF of water surface area

1. Non-programmed park land includes passive recreation and picnic areas that are not scheduled for regular activities. Unusable park land such as steep slopes or natural areas shall not be used in calculating parking space requirements.

### 3.2.7 Open Space (OS)

#### A. Description

The Open Space (OS) designation refers to open space areas outside of the Habitat Preserve within Fanita Ranch, including brush management areas at the edge of development (Fuel Modification Zones 1A, 1B and 2 – see the Fuel Modification Zone cross section exhibits in Fanita Ranch EIR Appendix P1), slopes adjacent to roads and within Villages, detention basins, trailheads and two riparian areas in Fanita Commons. Fire management areas and riparian open space are described in greater detail in *Chapter 5: Landscape Architecture, Community Design & Outdoor Lighting Design Plan*, *Chapter 8: Grading, Utilities & Services* and *Chapter 9: Open Space, Conservation & Sustainability*.

Within the OS land use designation, the open space and basin areas denoted as “OS” and “OS-B” on *Exhibit 3.2: Site Utilization Plan* will be maintained and managed by the Homeowners Association. Areas that contain pump stations and water tanks, shown as “OS-PS” and “OS-WT” on *Exhibit 3.2: Site Utilization Plan*, will be dedicated to and maintained/operated by the Padre Dam Municipal Water District (PDMWD). All OS land use designation areas are subject to the Fanita Ranch Fire Protection Plan (Fanita Ranch EIR Appendix P1).

#### B. Permitted Uses

Permitted Uses in OS Land Use Designation Areas
Agriculture including orchards, vineyards, crops
Apiaries
Cultural and historic monument, public art
Gardens - Community, children's, educational, demonstration, therapy, botanical and similar uses
Habitat enhancement riparian areas
Interpretive signage, trail markers, building identification and other wayfinding and educational signage
Non-combustible kiosks, benches, shade structures, bike repair stations and similar trail amenities
Public utilities, associated rights-of way and grading (including photo voltaic)
Trailheads
Walking and biking trails (no equestrian)
Water quality features including swales, basins, bio-retention areas and other BMPs



### 3.2.8 Agriculture (A) Overlay

#### A. Description

The Agriculture (A) overlay applies to areas reserved for the Farm and other agricultural uses. The Farm in Fanita Commons is the centerpiece of Fanita Ranch and honors Santee’s long tradition of agriculture. The Farm is planned to include a large iconic barn that will set the architectural theme of the community and provide a venue for special events and farm operations. The working farm will also include terraced vegetable fields, pasture lands, limited housing for employees, raised gardens and pastures/facilities for farm animals. The Farm will engage residents through volunteer opportunities, educational experiences, field trips, internships, festivals, a farm stand, Community Supported Agriculture (CSA) programs and more.

The underlying land use for the A overlay planning area is OS. The underlying OS land use designation may be implemented in the A overlay planning areas, in accordance with the provisions set forth in *Section 3.2.7: Open Space*, if uses permitted within the A overlay become infeasible in the A overlay planning areas. Caretaker units and commercial accessory uses are only permitted when the A overlay is applied to these planning areas.

#### B. Permitted Uses

Permitted Uses in A Overlay Areas
<b>Agricultural Uses</b>
Agriculture including orchards, vineyards, crops <sup>7</sup>
Gardens - Children’s, educational, demonstration, therapy, botanics, raised garden beds and similar uses
Pick-your-own operations and sales
Professionally managed community gardens and community supported agriculture
<b>Accessory Uses</b>
Accessory uses typically associated with agricultural uses
Apiaries and commercial animal keeping, husbandry and education programs such as 4H youth organizations (no butchering or slaughtering permitted) <sup>5</sup>
Accessory structures - Greenhouses, barns, post-harvesting facilities and similar structures for housing animals, storing equipment and supporting farm operations <sup>6</sup>
Composting, organic recycling and animal manure management practices <sup>4</sup>
Outdoor and commercial kitchens, amphitheaters and similar facilities associated with farm education and promotion
Commercial recreation, outdoor - including mazes, kiddie rides, pony rides, petting zoos and similar uses
Drying, processing and packing of fruits, nuts, vegetables and other products (outdoors or in permanent, accessory structures)
Offices - Farm administrative offices and other non-profit office space, including non-profit incubators
Outside storage of materials, such as irrigation equipment and farming machinery, stored in conjunction with the Farm

Permitted Uses in A Overlay Areas
Parking lots
Temporary events such as outdoor markets, Certified Farmers' Markets, pumpkin patches, Christmas tree lots, festivals, carnivals, outdoor entertainment, art shows and similar events <sup>1</sup>
Water quality features including swales, basins, bio-retention areas and other BMPs
Up to 6 caretaker units (units to be transferred from elsewhere in the Specific Plan Area)
Accessory Commercial Uses
Community event venues with or without live entertainment, dancing and similar for weddings, conferences and similar events <sup>2</sup>
Farm lab and other educational activities related farming, gardening, food, nutrition and artisanal crafts
Food sales - Farmer's market, farm stands, food halls, specialty food markets, restaurants, delicatessens, cafes, tasting rooms and similar uses (including sale of alcohol for on-site and off-site consumption) <sup>2</sup>
Food related craft industries including, but not limited to, wineries, creameries, micro-breweries, bakeries, micro-distilleries and similar uses <sup>2</sup>
Garden center, nurseries, plant storage or plant propagation
Kennels and boarding facilities for animals
Lodging - farm-stay, bed and breakfast
Non-food related craft industries such as glass blowing, blacksmithing, metal working, jewelry making, pottery, baskets, natural apparel, art production and similar uses
Retail - stores that sell goods and merchandise associated with the Farm
Retail space for sales associated with local cottage and local craft industries (food and non-food)
Studios and galleries - art, music, photography and similar uses
Studios and pavilions for fitness/wellness programs such as yoga and similar uses
Wedding chapels, religious and spiritual assembly space and similar uses <sup>3</sup>

1. Temporary events and uses shall be subject to the applicable criteria and conditions of SMC Section 13.06.070. Special and temporary event attendance shall be limited to a maximum of 300 attendees.
2. See *Section 3.2.11.11 (B): Sale of Alcohol* for applicable regulations.
3. See *Section 3.2.11.11 (C): Places of Worship or Assembly* for applicable regulations.
4. See *Section 3.2.11.11 (A): Agriculture and/or Animal Keeping in Agriculture Overlay Areas* for applicable regulations.
5. Keeping, raising and boarding of large and small 4-legged animals, as defined in SMC, is permitted. The number of 4-legged animals shall not exceed 5 animals per gross acre of the Agriculture overlay areas. Keeping, raising and boarding of fowl such as chickens, roosters, ducks, geese and other similar fowl is also permitted.
6. Accessory structures for animal keeping shall occupy no more than 25% of the property on which they are located.
7. Farm equipment operations shall be limited to 7 a.m. to 7 p.m.

**C. Development Standards**

Lot Standards <sup>4</sup>	
Min. Net Lot Area	None
Max. Caretaker Units	6
Accessory Commercial Uses <sup>2</sup>	Up to 20,000 square feet of floor area
Minimum Lot Depth	None
Minimum Lot Width	None
Maximum Height <sup>3</sup>	35 feet (3 Stories) <sup>1</sup>
Minimum Building Separation	10 feet
Minimum Setbacks <sup>3</sup>	
Public Street Right-of-Way to Any Building	20 feet
From Public Street Right-of-Way to Parking Areas	10 feet

1. Silos, windmills, water tanks and similar iconic auxiliary structures may exceed the 35-foot structure height limit, subject to approval from Federal Aviation Administration.
2. Does not include accessory structures associated with farm operations.
3. See *Section 3.2.11.1* for projection, encroachment and height exceptions.
4. Where development standards are not provided herein, those standards will be determined at the Development Review stage.



**D. Appropriate Building Typologies**

- Detached Cluster Homes
- Attached/Semi-Detached Homes
- Community Buildings



### E. Parking Requirements

Minimum vehicle parking requirements shall be as stated herein. Parking requirements may be refined in the Farm Operations Manual. The minimum number of required vehicle parking spaces for the Agriculture overlay areas is based upon the Farm's relationship to the adjacent Village Center and the overall community, but may be modified to reflect the mix of uses proposed on the site based upon a shared parking scenario. Parking may be shared with the adjacent Village Center subject to a site-specific shared parking agreement.

Bicycle parking shall be provided as specified by CALGreen.

Minimum Number of Required Vehicle Spaces by Use	
Caretaker Units	
Studio & one bedroom units	1 per unit
Two or more bedroom units	2 per unit
Agricultural	1 per employee (not including employees who live on-site)
Accessory Commercial Uses	1 per 250 square feet of floor area
Lodging	1 per key + 2 spaces

### 3.2.9 Special Use (SU)

#### A. Description

The Special Use (SU) land use designation applies to a 31.9-acre site located in the southwestern portion of the Specific Plan Area, west of the existing PDMWD Carlton Hills water reservoir. The SU area was previously graded for a City park during repair of the Oak Hills Landslide in the late 1970s/early 1980s. The site includes multiple relatively level sheet graded pads totaling approximately 24.5 acres. Geotechnical conditions make the site unsuitable for park development. The SU area falls within the Gillespie Air Field notification area and has a 35-foot height limitation.

The Fanita Ranch Specific Plan identifies permitted uses for the SU land use designation area, including water quality basins, the extension of Carlton Hills Boulevard, a solar farm, recreational vehicle (RV) and boat storage and above-ground agriculture. These uses are described below and shown in *Exhibit 3:3: Special Use Area Concept Plan* and *Table 3.3: Special Use Area Permitted Uses and Statistical Summary*. Due to site conditions, no significant grading or introduction of water into the soil is proposed in conjunction with implementation of permitted uses. Retail sales and residential uses, except one caretaker unit, are not permitted within the SU area. Access to the SU area is provided via the extension of Carlton Hills Boulevard. Uses in the SU area are buffered from adjacent existing homes by an OS slope area (a min. 100-foot non-irrigated FMZ) to the west to be managed by the HOA, and a 50-foot buffer along the south and southwest perimeter to be managed by the SU area owner/operator. A 50-foot non-irrigated FMZ is planned adjacent to the Habitat Preserve, to be maintained by the HOA. The SU area will be fenced at the perimeter, as shown in *Exhibit 5.18: Conceptual Fence and Wall Plan*. Security lighting will be provided in the SU area as indicated in *Exhibit 5.19: Conceptual Lighting Plan*.

#### B. Permitted Uses and Statistical Summary

*Exhibit 3:3: Special Use Area Concept Plan* depicts the locations of the following permitted uses within the SU area:

- **Water Quality/Hydromodification Basins**

A series of six water quality hydromodification basins are conceptually located within the SU area. These basins are designed to control and treat run-off from the SU area before conveying flows to the existing public storm drain system.

- **Extension of Carlton Hills Boulevard**

Carlton Hills Boulevard will be improved and extended northerly from its existing terminus into the SU area. The road is proposed as a two-lane road terminating adjacent to the PDMWD Carlton Hills water reservoir. The roadway will provide vehicular access to the reservoir and the proposed mini park, which is planned to include a trail staging and parking area.





**LEGEND**

- Specific Plan Boundary
- Special Use Area
  - ① Solar Farm and RV/Boat Storage
  - ② Above-Ground Agriculture or Solar Farm and RV/Boat Storage
  - ③ Non-Utilized Area
- 50' Managed Buffer
- Basins, Slopes and Easements
- Carlton Hills Boulevard Extension
- Mini-Park\*
- Open Space - 50' Fuel Modification Zone 2 (Non-Irrigated/70% Thinning)
- Open Space - 100' Fuel Modification Zone 2 (Non-Irrigated/70% Thinning)
- Habitat Preserve

\* Parking for the mini-park will be provided along the west side of Carlton Hills Boulevard - see Exhibit 4.12.15: Carlton Hills Boulevard and the Trail Staging Area in Exhibit 7.8: Typical Vista Point and Trailhead Concept Plan.

⊕ not to scale

**Exhibit 3.3: Special Use Area Concept Plan**



*Special Use*

- **Solar Farm and RV/Boat Storage**

Solar farm and RV/boat storage areas are proposed within approximately 18.4 acres designated ① on *Exhibit 3.3: Special Use Area Concept Plan*. These uses would occur on the graded pads located to the west and northwest of Carlton Hills Boulevard. A 50-foot buffer from adjacent existing homes would be provided along the southwestern limits of the SU area. Adjacent to the western edge of the SU area, a slope area would be designated a minimum 100-foot non-irrigated FMZ between existing single-family homes off-site and the SU area. Solar farm and RV/boat storage may also occur on the pad located southeast of Carlton Hills Boulevard within the area designated ②, which is described below.

- **Above-Ground Agriculture**

Above-ground agriculture is proposed within approximately 2.4 acres designated ② on *Exhibit 3.3: Special Use Area Concept Plan*. Above-ground agricultural uses would include water collection and reuse infrastructure that would prevent introduction of water into the soil. Solar farm and/or RV/boat storage may also occur within the area designated ②.

- **Non-Utilized Area**

A non-utilized area, approximately 1.3 acres, is located east of the extension of Carlton Hills Boulevard and is designated ③ on *Exhibit 3.3: Special Use Area Concept Plan*. No use is proposed for the non-utilized area at this time.

Several other land uses are depicted on *Exhibit 3.3: Special Use Area Concept Plan* for context but are not included within the overall 31.9-acre SU area. These land uses include a 1.6-acre mini park located west of Carlton Hills Boulevard which is planned as a trail staging area with parking, and OS designated areas surrounding the SU area which consist of non-irrigated/thinned FMZs as discussed in *Section 8.6.2.1* of the Specific Plan. The mini park and OS acreages are included in their respective land use designations in *Table 3.1: Land Use Plan Statistical Summary* and *Table 3.2: Site Utilization Plan Summary*.

**Table 3.3: Special Use Area Permitted Uses and Statistical Summary**

Area/Use	Acreage
Solar Farm <sup>1</sup> and RV/Boat Storage <sup>2</sup> ①	18.4
Above-Ground Agriculture or Solar Farm and RV/Boat Storage ②	2.4
Non-Utilized Area ③	1.3
50' Buffer, Basins, Slopes and Easements	8.7
Carlton Hills Boulevard Extension	1.1
Caretaker Unit (to be transferred from another planning area)	--
<b>Special Use Area Total</b>	<b>31.9</b>

1. Includes solar farm and associated devices, equipment and infrastructure for solar energy collection, storage and distribution.
2. Recreational vehicle and boat storage hours of operation shall be limited to 7 a.m. to 7 p.m. on Mondays through Saturdays and 10 a.m. to 7 p.m. on Sundays. After hours drop-off and pick-up shall be at a specified location on-site to mitigate potential noise impacts on adjacent residences per the Noise Technical Report (see Fanita Ranch EIR Appendix L), as determined during the Development Review process.

### C. Development Standards

Development standards for the SU land use designation considers the site's relationship to Gillespie Air Field and adjacency to off-site neighbors. Height has been limited to 35 feet in conformance with the Gillespie Air Field Airport Land Use Compatibility Plan (ALUCP). A 50-foot minimum managed buffer is required adjacent to existing homes off-site to preserve neighbor privacy. Planting and irrigation may be subject to the recommendations of a focused geotechnical study.

### D. Landscaping

Landscaping shall be limited and shall be consistent with the requirements of the Fanita Ranch Fire Protection Plan (Fanita Ranch EIR Appendix P1). Landscape plans shall be approved by the Santee Fire Department.

Lot Standards <sup>1</sup>	
Min. Net Lot Area	None
Min. Lot Depth	None
Min. Lot Width	None
Max. Lot Coverage, including all Buildings and Accessory Structures	90%
Maximum Height	35 feet
Minimum Setbacks	
Public Roadway to any Building	20 feet
From adjacent Residential Property Lines <sup>2</sup>	50 feet

1. Where development standards are not provided herein, those standards will be determined at the Development Review stage.
2. Screening treatments may include solid perimeter fencing/walls, berming, architectural screens or similar features to visually screen development from adjacent neighbors. Walls and fencing shall be subject to the requirements of [Section 3.2.11.8](#).

### 3.2.10 Habitat Preserve (HP)

#### A. Description

The Habitat Preserve land use designation applies to open space areas outside the limits of development, as shown in *Exhibit 3.1: Land Use Plan* and *Exhibit 3.2: Site Utilization Plan*. It includes specific revegetated slopes at the edge of the development area. Revegetated slopes will consist of native materials planted to blend back into the existing natural landscape in conformance with a Habitat Restoration Plan. The intent of this land use is to designate areas that will ultimately be included in the City of Santee Subarea Plan, fulfilling the City’s commitment to participate in the San Diego Multiple Species Conservation Program (MSCP).

#### B. Permitted Uses

Permitted uses include trails, fencing (where necessary), interpretive signage, habitat restoration and revegetation, roadways necessary for public access, utilities and other uses consistent with the Natural Community Conservation Planning (NCCP) design guidelines and standards. Wireless telecommunication facilities that generally have minimal onsite maintenance and lighting are permitted, subject to the provisions of the NCCP.



### **3.2.II Regulations Applying to Multiple Land Use Designations**

The Specific Plan Area is located in a Wildland-Urban Interface (WUI) area. As such, planning, design and construction of all buildings within the Specific Plan Area shall comply with the applicable regulations and standards of SMC as may be amended from time to time, California Building Code Chapter 7A and Fanita Ranch Fire Protection Plan.

Unless stated otherwise within this Specific Plan, the following standards shall also apply to all land use designations.

#### **3.2.II.1 Projections, Encroachments and Height Exceptions**

- A. Projections and encroachments into setbacks shall comply with the requirements and limitations of the Fire Protection Plan.
- B. Eaves, roof projections, awnings and similar architectural features, when located at least 8 feet above grade, may project into required setbacks a maximum distance of 3 feet, provided that such feature shall be at least 3 feet from a property line. There shall be no combustible awnings, canopies or similar combustible overhangs within Fuel Modification Zone 1A.
- C. Fireplaces, chimneys, bay windows, balconies, fire escapes, exterior stairs and landings, and similar architectural features may project into the required setback a maximum distance of 2 feet and shall be at least 3 feet from a property line.
- D. Uncovered decks, platforms, uncovered porches and landing places which do not extend above the first floor level of the main building and are not at any point more than 32 inches above grade, may project into any rear or interior side setback up to the property line. Where not extending above the first floor level but where greater than 32 inches above grade, they must be at least 5 feet from all side property lines and 10 feet from the rear property lines.
- E. If a structure is constructed such that it projects over a slope and the structure is visible from a public street, the underside of the structure shall either be enclosed, or landscaping shall be provided to screen the underside of the structure from public view. Projections shall be 1-hour rated and approved by the Santee Fire Department prior to issuance of a building permit. Any landscape screening shall be approved by the Santee Fire Department.
- F. Unless otherwise specified in this Specific Plan, flues, chimneys, antennas, elevators, or other mechanical equipment or utility may exceed the height limit by up to 15 feet, provided such feature shall not be used for habitable space and an appropriate architectural treatment or screening is provided, as determined by the Development Services Director.

- G. Architectural appurtenances such as steeples, towers and similar design elements on commercial structures may exceed the maximum height by up to 10 feet. Additional height may be approved by the Development Services Director through a Development Review permit process if it is determined that architectural compatibility and appropriate building scale are achieved and maintained.

### 3.2.II.2 Accessory Dwelling Units

Accessory dwelling units (ADUs) are permitted within the LDR and MDR land use designation areas to allow for multi-generational households and opportunities for additional rental housing options. An ADU is a residential dwelling unit that is detached from, attached to or located within the living area of a primary dwelling unit and is located on the same lot as the primary dwelling unit. ADUs are subject to California state laws, as they may be amended from time to time.

### 3.2.II.3 Accessory Uses and Structures

Accessory structures, excluding ADUs, include attached and detached structures that are not part of the primary building and require a building permit. Such uses include, but are not limited to, unenclosed patio covers, cabanas, detached garages, carports, play structures and storage sheds. Accessory structures located in Fuel Modification Zone 1A (setback zone, as described in *Section 8.6.2.1: Fuel Modification Zones*) shall be limited to decks, patio covers, gazebos, arbors and other non-habitable structures of non-combustible construction and shall be approved by the Santee Fire Department.

Accessory structures shall be subject to applicable criteria provided in the Fire Protection Plan.

- A. **Interior Side and Rear Setbacks.** Unless otherwise specified in this Specific Plan or the Fire Protection Plan, accessory structures may encroach into a required interior side or rear setback up to 5 feet from the property line, excluding eave overhang.
- B. **Front and Exterior Side Setback.** No attached or detached accessory structure shall occupy any portion of a required front or exterior (corner) side setback.
- C. **Height.** A height limit of 15 feet (one story) shall apply within the required setback area.
- D. **Minimum Separation.** Accessory structures shall maintain a minimum separation of 6 feet from the main structure.
- E. **Size.** Detached accessory structures shall occupy no more than 25% of a rear yard.



- F. **Outdoor Recreation.** Swimming pools, spas, tennis courts, basketball courts or similar paved outdoor recreational courts shall not be located in any required front setback and shall be located no closer than 3 feet from any rear, side or corner side property line.
- G. **Lighting.** Unless otherwise specified in this Specific Plan, outdoor lighting poles and fixtures associated with accessory uses and structures shall not exceed 15 feet in height, unless otherwise approved by the Development Services Director. All lighting shall be designed to project light downward and shall not create glare on adjacent properties.

#### 3.2.11.4 California Rooms

The California Room provides a transition from indoor to outdoor environments and may include options such as built-in fireplaces, pre-wired lighting or fan fixtures for comfort and entertaining. The California Room is typically accessed through sliding or folding doors at the rear or side of the home, and the space acts as a transition to the backyard and the entertaining opportunities there. The area is notched into the main dwelling with a solid roof integral to the home. California Rooms may not be located in Fuel Modification Zone 1A. California Rooms must meet the following requirements, unless approved by the Development Services Director:

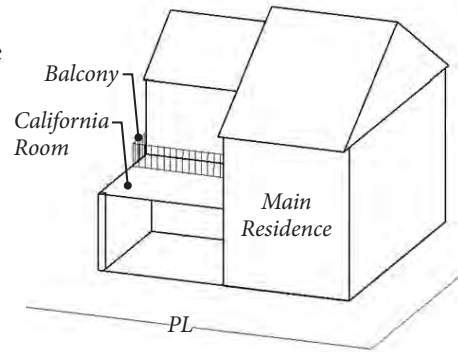


*California Room*

- A. California Rooms must have at least two open sides or have movable, transparent walls/windows that open to the rear and/or side setback;
- B. The rear setback from a California Room may be a minimum of 5 feet, provided the California Room's width does not exceed 50% of the residence's width. California Rooms shall be equipped with automatic residential fire sprinklers. The side setbacks of a California Room shall be subject to the side setback requirements of the primary building.
- C. If the rear setback of the California Room is less than 10 feet, the rear elevation of the California Room must be open.
- D. Second story living areas above the California Rooms shall be subject to the setback requirements of the primary building.

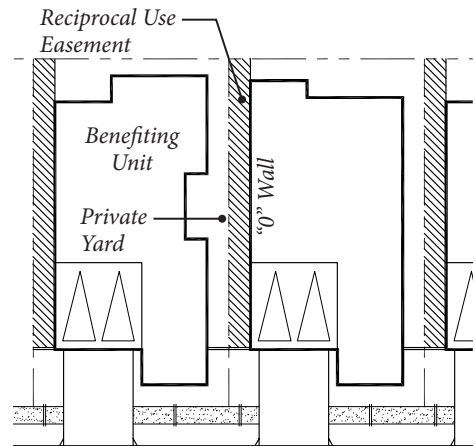
E. Second story balconies above the California Rooms may not extend more than 50% over the California Room and are permitted in the following conditions:

1. Permitted on lots with rear setbacks adjacent to open space unless otherwise prohibited by the Fire Protection Plan.
2. Permitted on any lot with a grade separation of 10 feet or more at the rear lot line.
3. Permitted on interior lots where the California Room is set back 15 feet or more from the rear property line.



### 3.2.11.5 Reciprocal Use Easements

Residential building typologies such as z-lot homes, rear loaded homes and motor court homes may utilize reciprocal use easements, subject to building code requirements. Properties with reciprocal use easements are plotted with conventional setbacks, but the wall is constructed such that the side setbacks of adjacent units are combined into one private yard for the use of one of the units. An easement shall be established through deed restrictions on the property benefiting from the combined yard space to allow maintenance access for the non-benefiting property. The side of the non-benefiting unit forms the “0” wall adjacent to the easement. The easement shall be of sufficient width to allow for maintenance of the “0” wall and to accommodate the overhang of the roof eave and gutter. Eaves along the “0” wall line may project a maximum of 18” over the adjacent property line. The easement shall be kept free of permanent obstructions such as sheds or fences without a gate. The “0” wall shall not have any doors or primary windows on the ground floor that face onto the easement of the benefiting unit’s yard area to preserve privacy.



Example of Reciprocal Use Easement

### 3.2.11.6 Equipment Screening

With the exception of photovoltaic (PV) and solar hot water (SHW) systems, equipment shall be screened from view to the extent permitted by the utility and/or service provider. This requirement applies whether the equipment is located on the roof, on the side of a building or on the ground. The method of screening shall be architecturally integrated with the building design or landscaping in terms of material, color, shape and size. Equipment screening with landscaping shall be approved by the Santee Fire Department.

### 3.2.11.7 Trash Enclosures

All trash enclosures shall be designed to meet the City's trash enclosure standards and the stormwater pollution prevention best management practices (BMPs) in the City's BMP Design Manual. Refuse and recycling material pickups shall be on a regular basis, or more often as needed, to keep collection bins from overflowing. Property owner/operator shall be responsible for the cleanliness and sanitary conditions of the trash enclosure areas. Structural elements of trash enclosures that are subject to damage (such as screens, covers and signs) shall be maintained by the property owner/operator. Maintenance agreements between the City and the owner/operator or maintenance deed restrictions may be required. If required, maintenance agreements or deed restrictions shall be executed by the property owner/operator before improvement plans are approved.

### 3.2.11.8 Fencing, Walls and Landscaping

- A. All required front and street side setbacks and parkways shall be landscaped. For parking lot landscaping requirements, see *Section 3.2.11.9: Parking* of the Specific Plan.
- B. Where feasible, infiltration BMPs shall be integrated into the landscape design to reduce the quantity and velocity of storm water discharging from paved areas.
- C. The visibility of decorative water features, including but not limited to, ponds, decorative fountains, basins, reflective pools and spray/mist fountains should be confined to areas of high visibility and high use. Re-circulating water shall be used for all decorative water features. All such features shall be designed such that they present a positive visual statement when water is not available.
- D. Landscape plans required pursuant to a Development Review Permit shall be prepared and signed by a registered landscape architect unless waived by the Development Services Director. All landscape plans shall be reviewed and approved by the Santee Fire Department.
- E. Property owners and applicable HOAs are responsible for the continual maintenance of their respective landscaped areas. All landscaped areas shall be kept free from weeds and debris and maintained in a healthy, growing condition, and shall receive regular pruning, fertilizing, mowing and trimming. Any damaged, dead, diseased or decaying plant material shall be replaced within 30 days from the date of damage.
- F. Fences and walls located in a required front setback, including courtyard and patio walls, shall not exceed 3.5 feet in height. Retaining walls within the required front setback shall not exceed 4 feet in height.

- G. Fences and walls located in a required exterior side, interior side or rear setback shall not exceed 6 feet in height. Walls required for noise mitigation may exceed this height limit, as determined by an acoustical analysis.
- H. Security fencing up to 6 feet in height located in the front and exterior side setbacks and up to 8 feet in height located in the interior side and rear setbacks may be approved by the Development Services Director. Security fencing located in the front and exterior side setbacks shall be constructed of decorative metal materials and shall be non-view obstructing.
- I. Fencing within the Habitat Preserve land use designation areas shall be provided in accordance with applicable Fanita Ranch EIR, Fanita Ranch FPP, and Habitat Restoration Plan requirements.
- J. All fences and walls shall be kept in good repair and adequately maintained at all times. Any dilapidated, dangerous or unsightly walls or fences shall be removed or repaired. Anti-graffiti surfaces shall be provided where surfaces are visible to the public.
- K. Retaining walls constructed next to public streets shall be constructed with decorative masonry materials. Anti-graffiti surfaces shall be provided. Plantable retaining walls shall be considered where a wall is 10 feet or more in height and visible from public spaces.
- L. A visibility clearance area shall be required on corner lots and at commercial driveway locations in which nothing shall be erected, placed, planted or allowed to grow exceeding 3.5 feet in height. For corner lots, such area shall consist of a triangular area bounded by the curbs of streets bounding the corner lot not less than 20 feet from their point of intersection. Sight distance triangles along streets and roads with 2,000 or more average daily trips (ADT) shall meet the City's current Public Works Standards and will be determined during the development review process and is dependent upon roadway geometry, topography, and anticipated vehicular speeds.
- M. Landscape and irrigation shall comply with the Santee Water Efficient Landscape Ordinance.
- N. All landscaping shall be designed, installed and maintained in conformance with the Fire Protection Plan and shall be approved by the Santee Fire Department.
- O. All fencing shall be designed, constructed and maintained in conformance with the Fire Protection Plan and shall be approved by the Santee Fire Department.

### 3.2.11.9 Parking

#### A. Shared Parking Agreements

Shared parking is encouraged for commercial, residential and/or office off-street parking. Parking facilities may be used jointly with parking facilities for other uses when operations are not normally conducted during the same hours or when peak hours vary. Shared parking agreements are subject to the approval of the Development Services Director and must meet the following conditions:

1. A parking study shall be submitted to the Development Services Director demonstrating that substantial conflict will not exist in the principal hours or periods of peak demand for the uses which the joint use is proposed.
2. Parking facilities designated for joint use should not be located further than  $\frac{1}{4}$  mile from any structure or use served.
3. A shared parking agreement shall be prepared to the satisfaction of the City Attorney and executed by all parties concerned, assuring the continued availability of the number of stalls designated for joint use.

#### B. Parking Design Standards

The parking space requirements for uses in each land use designation area are provided in [Section 3.2.1](#) to [Section 3.2.10](#). The design standards for the parking areas are listed below:

1. **Stall Size.** Each parking space shall consist of a rectangular area not less than 9 feet wide by 19 feet long. The required minimum measurements may not include the exterior walls or supports of any structure. Parallel spaces shall be a minimum of 9 feet wide by 23 feet long. All parking spaces shall have a vertical clearance of not less than 7.5 feet. Parking spaces may overhang adjacent landscape areas up to 2.5 feet, provided the overhang does not extend into any required landscape setback area.
2. **Motorcycle Stall Size.** Those areas designated for use by motorcycles shall consist of a minimum usable area of 54 square feet.
3. **Recreational Vehicles.** Parking, storing or loading of recreational vehicles on public or private streets, other public areas or in driveways for more than 72 hours is prohibited.
4. **Garage Size.**
  - a. One-car garages for residential dwellings shall have a minimum interior dimension of 10 feet in width and 20 feet in depth of unobstructed area provided for parking purposes.



- b. Two-car garages for residential dwellings shall have a minimum interior dimension of 20 feet in width and 20 feet in depth of unobstructed area provided for parking purposes.
  - c. Two-car tandem garages for residential dwellings shall have a minimum interior dimension of 10 feet in width and 40 feet in depth of unobstructed area provided for parking purposes.
  - d. All garages for residential dwellings shall provide a minimum vertical clearance of 7.5 feet.
5. **Driveways.**
- a. Driveways providing access to garages, carports and parking areas serving more than one garage shall be a minimum width of 20 feet. Where feasible, shared driveways shall be used to reduce impermeable area. Where feasible, permeable surfaces, such as permeable concrete or permeable pavers, are encouraged.
  - b. All driveway and access way widths and designs must be approved by the Santee Fire Department for purposes of emergency accessibility.
6. **Paving.** Except in the Agriculture overlay areas, parking and loading facilities shall be surfaced and maintained with asphalt concrete, concrete or other permanent surface material sufficient to prevent mud, dust, loose material and other nuisances from entering the storm drain. Permeable surfaces, such as permeable concrete or permeable pavers, are allowed for parking lots. Crushed aggregate, rock, dirt or similar types of surfacing shall not be used as a permanent parking or loading facility surface but are permitted in Agriculture overlay areas. Unpaved roadways and parking in areas within the Agriculture overlay lands shall be designed to include swales and other BMPs.
7. **Landscaping.** Paved parking lots shall be landscaped according to the following standards:
- a. A minimum of 10% of the total off-street parking area shall be landscaped with appropriate ground cover and at least one 24-inch box tree with root barrier at a ratio of one tree per 5 required parking spaces. Parking lot trees may be clustered and are not required to be spaced at regular intervals. The parking area shall be computed by adding the areas used for access drives, aisles, stalls, maneuvering and landscaping within the portion of the premises that is devoted to vehicular parking and circulation.
  - b. Each unenclosed parking facility shall provide a perimeter landscaped strip at least 5 feet wide (inside dimension) where the facility adjoins a side property line. The perimeter landscaped strip may include any landscaped setback or landscaped area otherwise required and shall be continuous, except for required access to the site or to the parking facility.

8. **Drainage.** All parking and loading facilities shall be graded and provided with permanent storm drainage facilities. Surfacing, curbing and drainage improvements shall be sufficient to preclude free flow of water onto adjacent properties, public streets, private streets or driveways and standing pools of water within the parking facility. Infiltration BMPs shall be integrated into the drainage design to reduce the quantity and velocity of storm water discharging into the storm drain system, consistent with the San Diego Regional Water Quality Control Board (SDRWQCB) requirements.
9. **Lighting.** Lighting within any parking facility or paved area shall be designed to reflect away from residential uses, adjacent properties, the Habitat Preserve, riparian areas and motorists. Light standards shall be a low-profile design and be compatible with the architectural design of adjacent buildings. Light fixtures shall not exceed 15 feet in overall height from the finished grade of the parking facility, except that light fixtures up to 25 feet in height may be permitted if it is determined by the Development Services Director that the size of the parking area and site design warrants a taller light fixture. Lighting shall be consistent with *Section 5.9: Conceptual Lighting Plan*. A photometric analysis shall be prepared demonstrating that the lighting program is consistent with the Fanita Ranch Specific Plan requirements provided herein.
10. **Safety features.** Parking lots, parking structures and loading facilities shall meet the following safety standards:
  - a. Safety barriers, protective bumpers or curbing and directional markers shall be provided to assure pedestrian/vehicular safety, efficient utilization and protection to landscaping, and prevent encroachment onto adjoining public or private property.
  - b. Parking lot circulation shall be designed to ensure visibility of pedestrians, bicyclists and motorists when entering and exiting a parking facility and individual parking spaces.
  - c. Internal circulation patterns, as well as the location and traffic direction of all access drives, shall be designed and maintained in accordance with accepted principles of traffic engineering and traffic safety.
11. **Noise.** Areas used for primary circulation of frequent idling of vehicle engines or for loading activities shall be designed and located to minimize impacts on adjoining properties. These areas shall include screening or sound baffling.
12. **Screening.** Unenclosed off-street parking areas shall be screened from view using one or any combination of the following methods:
  - a. Low profile walls, not exceeding 3.5 feet in height, consisting of stone, brick or similar types of decorative solid masonry materials.

- b. Plant materials consisting of compact evergreen plants with a minimum height of 3.5 feet within 18 months after initial installation or screening as per (a) or (c) shall be installed.
- c. Berms. Earthen berm at least 3.5 feet above grade.
- d. In order to allow law enforcement surveillance into parking lots, the above screening methods shall be designed to provide for view corridors into the site from adjacent streets and properties. Screening and planting materials shall be approved by the Santee Fire Department.

13. **Parking Structures.** The following additional design standards shall apply to parking structures:

- a. Storage lockers, when provided, shall be placed so as not to preclude parking of a vehicle in a stall.
- b. A storage/maintenance room shall be included in the facility.
- c. High efficiency lighting shall be used in conjunction with daylighting for above grade structures.
- d. Elevators and/or stairwells shall be designed to allow complete visibility for persons entering and exiting.
- e. Floor surfaces shall be non-slip surfaces.
- f. Security devices shall be installed, such as surveillance cameras, audio and emergency call buttons.
- g. When mechanical ventilation systems are required, they shall be high efficiency systems and back-up power systems shall be installed.
- h. Points of intersection between pedestrians and vehicles shall be designed for adequate safety of movement; separate paths for the pedestrians from their cars to specific points of destination shall be integrated in the facility.
- i. Wayfinding signs shall be installed.

14. **Electric Vehicle (EV) Chargers.** EV chargers shall be installed in all homes within the Low Density Residential land use designation areas, some homes in the Medium Density Residential, Active Adult and Village Center land use designation areas, as well as within the parking lots of commercial projects in the Village Centers (see Fanita Ranch EIR Appendix H, Greenhouse Gas Analysis).

### 3.2.11.10 Performance Standards

Performance standards for specific uses are provided below to maintain or remedy land use compatibility, security or crime control issues that may result in a nuisance to surrounding residents.

#### A. Agriculture and/or Animal Keeping in Agriculture Overlay Areas

1. All Agriculture overlay lands and associated operations shall be professionally managed to ensure the Farm is well maintained and farming activities do not become a nuisance to neighboring residents.
2. The site and activities on-site shall be designed to minimize noise. The use of mechanical equipment such as tractors, exhaust fans, circulating pumps and/or generators and other exterior noise-generating operations that result in a one-hour average sound level of 50 decibels or more, as measured at the nearest adjacent residential property line, shall be limited to the hours of 7:00 a.m. and 7:00 p.m. Noise barriers shall be installed around any noise generating equipment if necessary to meet the required limitations.
3. All exterior lighting, including spotlights, floodlights, electric reflectors and other means of illumination for signs, structures, landscaping, parking, loading, unloading and similar areas, shall be focused, directed and arranged to prevent glare and direct illumination of streets, adjoining properties or the Habitat Preserve.
4. The site and activities on-site shall be designed to minimize offensive odors. An odor is offensive if it can be detected from a nearby residential or commercial use or an adjoining right-of-way. All poultry and animal enclosures shall be maintained in a clean, sanitary condition, free from offensive odors at all times. Evidence of unsanitary conditions includes, but is not limited to, numerous flies, fly larvae in the vicinity of the property, an accumulation of debris, refuse or manure, offensive odors and rat droppings. All composting, refuse, manure and any material conducive to the breeding of flies or which would create any offensive odor, shall be placed in suitable tight containers or bags until entirely removed from the premises or turned under the soil surface where such materials are used as fertilizer.
5. Composting, recycling and animal manure management practices on the Farm and in other Agriculture overlay areas shall be kept not less than 50 feet from any dwelling unit or public right-of-way. Screening may be required. Composting operations on the Farm and in other Agriculture overlay areas shall follow City of Santee, San Diego County and State of California best management practices and regulations as amended from time to time.
6. On-site advertising signs shall be consistent with *Section 3.2.11.11: Signage* of this Specific Plan and comply with all applicable City of Santee signage requirements.

7. All residential, commercial and mixed-use properties within Fanita Ranch shall record a Right-to-Farm covenant to protect the ongoing operation of agricultural uses.
8. All agricultural areas shall be maintained in conformance with the Fire Protection Plan.

### **B. Sale of Alcohol**

All businesses or establishments offering the sale of alcoholic beverages, for consumption both on and off-site, shall be required to obtain and continuously maintain all applicable California Department of Alcohol Beverage Control licenses. All City permits and business licenses related to the property and/or use shall be contingent upon the maintenance of required State licenses.

### **C. Places of Worship or Assembly**

1. All places of worship and assembly shall maintain adequate circulation and access so as not to block or impede public rights-of-way or emergency access. The City shall reserve the right to require a parking and access management plan if the Development Services Director determines that the use, as operated or maintained, results in inadequate access and circulation.
2. The subject use shall be operated in a manner which does not create a public or private nuisance. Any such nuisance must be abated immediately upon notice by the City.
3. The subject use shall be conducted in full compliance with all applicable local and state laws and regulations.
4. The site shall be maintained free of litter, refuse and debris. Cleaning shall include keeping all publicly used areas free of litter, trash, cigarette butts and garbage.
5. The subject use shall meet all requirements of the Santee Fire Department, including, but not limited, to the maximum occupancy of the facility.

### **3.2.11.11 Signage**

A comprehensive community signage program for Fanita Ranch shall be submitted to the Development Services Director for review and approval prior to the issuance of the first building permit(s). All signage in Fanita Ranch shall comply with the applicable provisions of SMC Chapter 13.32, except when the comprehensive community signage program expressly provides any specific new or alternative standards. Temporary real estate wayfinding and identification signs indicating the name, location, use and related information of Fanita Ranch, Villages and model homes shall be addressed in the community signage program.



### 3.2.II.12 Stormwater Low Impact Development Standards

Fanita Ranch utilizes a comprehensive Low Impact Development (LID) design approach with the objectives of maintaining a landscape functionally equivalent to pre-development hydraulic conditions and minimizing the generation of pollutants of concern to protect water quality and associated aquatic habitat. Development projects within Fanita Ranch shall include, but not be limited to, the following measures:

- A. Applicable and feasible LID practices and best management practices (BMPs) consistent with the City of Santee BMP Design Manual, County of San Diego LID Manual and the Fanita Ranch EIR.
- B. Source control and treatment control BMPs that reduce storm water pollutants of concern in urban runoff, including storm drain system stenciling and signage, inlets fitted with State certified trash capture devices, fully enclosed outdoor trash and material storage areas, and efficient irrigation systems.
- C. LID BMPs, where feasible, that minimize disturbances to natural drainages, maximize infiltration, provide retention, slow runoff, minimize impervious footprint, direct runoff from impervious areas into landscaping, minimize soil compaction, and construct impervious surfaces to minimum widths necessary provided that public safety and a walkable environment for pedestrians are not compromised. Examples of Site Design LID BMPs include using permeable pavements, rain gardens, rain barrels, grassy swales, soil amendments and native plants.
- D. Green Street techniques along portions of Fanita Parkway, Cuyamaca Street and Magnolia Avenue that include bio-filtration features to slow, filter and cleanse stormwater runoff from imperious surfaces.
- E. Buffer zones for natural water bodies, where feasible. Where buffer zones are infeasible, other buffers such as trees, access restrictions, etc., shall be implemented where feasible.
- F. For development projects with landscaped or other pervious areas, impervious areas (rooftops, parking lots, sidewalks, walkways, patios, etc.) shall drain into pervious areas prior to discharging to the municipal separate storm sewer systems (MS4s). The amount of runoff from impervious areas to be drained to pervious areas shall correspond with the total capacity of the project's pervious areas to infiltrate or treat runoff, taking into considerations the pervious areas' soil condition, slope, and other pertinent factors.
- G. For development projects with landscaped or other pervious areas, properly design and construct the pervious areas to effectively receive and infiltrate or treat runoff from impervious areas, taking into consideration the pervious areas' soil conditions, slope and other pertinent factors.

- H. For development projects with low-traffic areas and appropriate soil conditions, construct a portion of walkways, trails, overflow parking lots, alleys or other low-traffic areas with permeable surfaces, such as pervious concrete, porous asphalt, unit pavers and granular materials. Additional provisions for parking lot paving, landscaping and drainage are included in *Section 3.2.11.9: Parking*.
- I. All structural post-construction BMPs within the project shall be operated and maintained into perpetuity. Proof of on-going, long-term maintenance of all post-construction BMPs shall be submitted annually to the Development Services Director or designee.
- J. Provide pet waste stations and trash receptacles at parks and along trails, where appropriate, to encourage responsible cleanup by residents.

# Chapter 4: Mobility

## 4.1 Mobility Plan

The Mobility Plan for Fanita Ranch focuses on reducing the number and the length of vehicle trips and providing alternatives to fossil fuel-powered vehicle use. This is achieved through organizing land uses to locate services and goods close to homes, and optimizing circulation systems to create direct, efficient, safe and comfortable routes for a variety of transportation modes. The Specific Plan Area land uses are designed to meet the daily needs of the Fanita Ranch residents to minimize trips outside of the Specific Plan Area. Emphasis is placed on encouraging transportation modes that generate fewer emissions, such as walking, biking, electric vehicles, transit and ride-sharing.

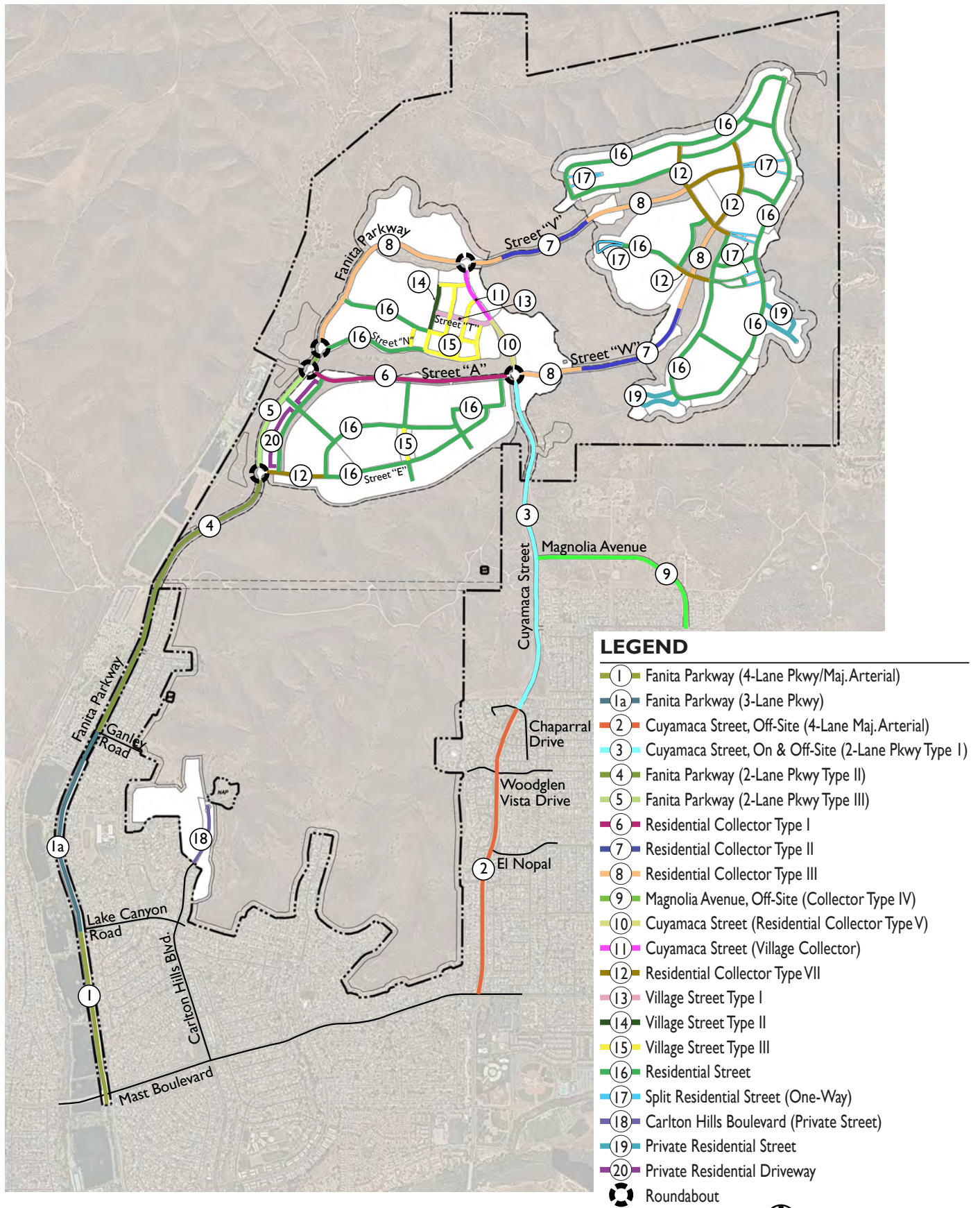
### 4.1.1 Regional Access

Santee is accessible via State Route 52 (SR-52), which connects to Interstate 5 (I-5) and Interstate (I-805) in the west and State Route 67 (SR-67) in the east. SR-67 and State Route 125 (SR-125), which also connects to SR-52, both provide connections to I-8 south of Santee. From SR-52, Fanita Ranch can be accessed directly from Cuyamaca Street, or indirectly via Mast Boulevard to Fanita Parkway or the extension of Magnolia Avenue from the existing terminus at Princess Joann Road to Cuyamaca Street.

### 4.1.2 Complete Streets

Streets within Fanita Ranch, as shown in *Exhibit 4.1: Circulation Plan*, are designed as a system of Complete Streets that safely accommodate and support multiple user types, including motorists, pedestrians, bicycles and transit riders. The benefits of Complete Streets include the following:

- A. Improved safety for multiple user types by providing adequate facilities and reducing traffic speeds.
- B. Balanced transportation systems that provide direct connections, variety of transportation choices, and reduced traffic congestion.
- C. Opportunities for healthier, more active lifestyles that include walking and bicycling.



**Exhibit 4.I: Circulation Plan**

⊕ not to scale

The Fanita Ranch Specific Plan establishes the street designs within the boundaries of the Specific Plan Area. Street improvements associated with development in Fanita Ranch include the extension of existing streets and the construction of a new internal system of public and private streets. The Specific Plan establishes a network of streets of varying design capacities tailored to meet the unique concepts of the three Villages. The Specific Plan street designs address safety, aesthetics and functionality as well as site constraints. The difference between the Specific Plan streets and the City of Santee Public Works Standards (February 1998) related to the street right-of-way (ROW) widths, curb-to-curb dimensions, sidewalk and median configurations are described in *Appendix B: Fanita Ranch Street Design*.

Within the Specific Plan Area, specially designed street sections respond to the physical characteristics of the site, including steep terrain and environmentally sensitive areas, and express the agrarian character through design and landscaping. Streets within Fanita Ranch are intended to provide diversity, uniqueness, and strong neighborhood identity while optimizing efficiency and user safety. Design elements include roundabouts, split streets, landscaped medians and parkways that will be planted with native and edible plant species to complement adjacent open space areas and the Farm. Roadways that pass through open space areas are designed to minimize impacts to habitat, maximize views to natural features and encourage the feasibility of potential wildlife crossings. *Table 4.1: Street Design Criteria* provides the design criteria for the streets within the Specific Plan Area. Street cross sections and landscape treatments are provided in *Section 4.2: Street Corridor & Landscape Standards*. Unless expressly provided otherwise herein, the street design criteria and standards contained in this Specific Plan shall govern over other applicable City street design criteria and standards with respect to Fanita Ranch.



Table 4.I: Street Design Criteria

PROPOSED SECTION – FANITA SPECIFIC PLAN	ADT RANGE (Santee Mobility Element Equivalent)	ESTIMATED ADT	DESIGN SPEED MPH	TRAVEL LANES	BIKE LANE	PARKING	MEDIAN WIDTH (FT)	CURB TO CURB (FT)	ROW (FT)	MAX GRADE % (f)	MAX GRADE % THROUGH INTERSECTION	MAX CENL. INTERSECTION ANGLE (DEG)	MIN. CENL (e) RADIUS (FT) STD. CROWN/FULL SUPER	MIN. TRAFFIC INDEX	STOPPING SIGHT DISTANCE	
NO.	NAME															
1	FANITA PARKWAY 4 LANE PARKWAY	15,000-40,000 4-Lane Parkway/ Major Arterial City Std. Optn. 2	15,460	50 <sup>(d)</sup>	4-12'	CLASS I & II	EMERGENCY, BOTH SIDES	14' <sup>(b)</sup> RAISED	68', 76'	89', 97'	7	5	10	1400/850	8.5	430'
1a	FANITA PARKWAY 3 LANE PARKWAY	15,000-40,000 4-Lane Parkway/ Major Arterial City Std. Optn. 2	15,130	50 <sup>(d)</sup>	2-12' + 1-12'	CLASS I & II	EMERGENCY, BOTH SIDES	14' <sup>(b)</sup> RAISED	57', 65'	89'-97'	7	5	10	1400/850	8.5	430'
2 Offsite	CUYAMACA STREET 4 LANE MAJOR ARTERIAL	15,000-40,000 4-Lane Major Arterial	18,630	50	4-12'	CLASS II	EMERGENCY, BOTH SIDES	14' RAISED	82'	102'	7	5	10	1400/850	8.5	430'
3 On & Offsite	CUYAMACA STREET 2 LANE PARKWAY TYPE I	5,000-15,000 2-Lane Parkway w/ TWLTL	13,920	40 <sup>(d)</sup>	2-12'	CLASS II	EMERGENCY, BOTH SIDES	10' <sup>(b)</sup> RAISED	52', 56'	70', 74'	12	5	10	800/550	8.0	300'
4	FANITA PARKWAY 2 LANE PARKWAY TYPE II	5,000-15,000 2-Lane Parkway w/ TWLTL	12,350	40 <sup>(d)</sup>	2-12'	CLASS I & II	EMERGENCY, BOTH SIDES	14' <sup>(b)</sup> RAISED	48', 56'	69', 77'	12	5	10	800/550	8.0	300'
5	FANITA PARKWAY 2 LANE PARKWAY TYPE III	5,000-15,000 2-Lane Parkway w/ TWLTL	9,730	40 <sup>(d)</sup>	2-12'	CLASS I & II	YES ONE SIDE, EMERGENCY ONE SIDE	10' RAISED	57'	83'	10	5	10	800/550	8.0	300'
6	RESIDENTIAL COLLECTOR TYPE I	4,000-10,000 Residential Collector/ 2-Lane Parkway	7,400	35 <sup>(d)</sup>	2-12'	CLASS II	YES ONE SIDE	10' PAINTED	53'	59', 69'	13	5	10	610/400	7.5	250'
7	RESIDENTIAL COLLECTOR TYPE II	4,000-10,000 Residential Collector/ 2-Lane Parkway	6,480	35 <sup>(d)</sup>	2-12'	CLASS II	EMERGENCY, BOTH SIDES	6' RAISED	48'	62'	15	5	10	610/400	7.5	250'
8	RESIDENTIAL COLLECTOR TYPE III	4,000-10,000 Residential Collector/ 2-Lane Parkway	6,480	35 <sup>(d)</sup>	2-12'	CLASS II	EMERGENCY, BOTH SIDES	14' RAISED	56'	78', 83'	12 <sup>(a)</sup>	5	10	610/400	7.5	250'
9 Offsite	MAGNOLIA AVENUE COLLECTOR TYPE IV	4,000-10,000 Collector/ 2-Lane Parkway	6,310	35 <sup>(d)(i)</sup>	2-13'	CLASS II	YES, BOTH SIDES	12' PAINTED	52'	67'	12	5	10	610/400	7.5	250'
10	CUYAMACA STREET RESIDENTIAL COLLECTOR TYPE V	4,000-10,000 Residential Collector/ 2-Lane Parkway	6,180	35 <sup>(d)(b)</sup>	2-12'	CLASS II	EMERGENCY, BOTH SIDES	10' RAISED	52'	75'	15 <sup>(a)</sup>	5	10	610/400	7.5	250'
11	VILLAGE COLLECTOR	4,000-10,000 Residential Collector/ 2-Lane Parkway	6,180	35 <sup>(d)</sup>	2-12.5'	N/A	YES, BOTH SIDES <sup>(c)</sup>	N/A	64'	88'	10	5	10	610/400	7.5	250'
12	RESIDENTIAL COLLECTOR TYPE VII	4,000-10,000 Residential Collector/ 2-Lane Parkway	4,300	25 <sup>(d)</sup>	2-12'	N/A	YES, BOTH SIDES	N/A	40'	62', 63'	12 <sup>(a)</sup>	5	10	200	7.5	160'
13	VILLAGE STREET TYPE I	2,200 (LOCAL)		25	2-12'	N/A	YES, BOTH SIDES	20' RAISED	60'	80'	12	5	10	200	5.0	160'
14	VILLAGE STREET TYPE II	2,200 (LOCAL)		25	1-12.5' + 1-10'	N/A	YES, BOTH SIDES	N/A	50'	70'	12	5	10	200	5.0	160'
15	VILLAGE STREET TYPE III	2,200 (LOCAL)		25	2-10'	N/A	YES, BOTH SIDES	N/A	36'	56'	12	5	10	200	5.0	160'
16	RESIDENTIAL STREET	2,200 (LOCAL)		25	2-10'	N/A	YES, BOTH SIDES <sup>(c)</sup>	N/A	36'	57', 58', 62'	15 <sup>(a)</sup>	5	10	200	5.0	160'
17	RESIDENTIAL STREET	2,200 (LOCAL)		25	2-10'	N/A	YES, BOTH SIDES <sup>(c)</sup>	N/A	42'	VARIES PER PLAN	15 <sup>(a)</sup>	5	10	200	5.0	160'
18	PRIVATE RESIDENTIAL STREET	2,200 (LOCAL)		25	2-12'	N/A	YES, ONE SIDE	N/A	32'	70' <sup>(b)</sup>	12	5	10	200	5.0	160'
19	PRIVATE RESIDENTIAL STREET	1,100 (PRIVATE)		15	2	N/A	SEE PLAN	N/A	VARIES PER PLAN	VARIES PER PLAN	12	5	10	35	5.0	100'
20	PRIVATE RESIDENTIAL DRIVEWAY	1,100 (PRIVATE)		15	2	N/A	N/A	N/A	VARIES PER PLAN	VARIES PER PLAN	12	5	10	35	5.0	100'

NOTES:

- A. THE STREETS WITH A GRADIENT EXCEEDING 12% SHALL BE PCC IN ACCORDANCE WITH PUBLIC WORKS STANDARDS, CITY OF SANTEE.
- B. MEDIAN WIDTH MAY BE REDUCED TO 6' IN THE VICINITY OF WETLAND AND/OR BIOLOGICAL IMPACTS PROVIDED THE REQUIRED TURN POCKETS FUNCTION PROPERLY. PARKWAY AND MEDIAN MAY HAVE UP TO A 4:1 SLOPE WHERE SHOWN ON PLANS.
- C. PARKING MAY BE ELIMINATED ON ONE SIDE WHERE SHOWN ON PLANS.
- D. ENTRY DESIGN SPEED OF A ROUNDABOUT SHALL BE 20 MPH.
- E. CURVE RADII SHOWN ARE PER CALTRANS TABLE 202.2 ASSUMING STANDARD CROWN SECTION. MINIMUM CENTERLINE RADIUS ON SUPER ELEVATED STREETS SHALL BE PER CITY OF SANTEE PUBLIC WORKS STANDARDS TABLE A.
- F. LIGHTED SAG VERTICAL CURVES CALCULATED AS  $L=0.0215AV^3$  MAY BE USED ON ANY STREET PROVIDED THAT STREET LIGHTS ARE INSTALLED TO THE SATISFACTION OF THE DIRECTOR OF DEVELOPMENT SERVICES.
- G. PARKWAY – PARKWAY IS DEFINED BY THE CITY OF SANTEE MOBILITY ELEMENT AS “ROADWAYS REQUIRING UNIQUE DESIGN APPLICATIONS WHERE STANDARD DESIGNS CANNOT BE UTILIZED BECAUSE OF STEEP TERRAIN, RIGHT-OF-WAY CONSTRAINTS, SPECIAL DEVELOPMENT NEEDS AND/OR OTHER SPECIAL CONDITIONS. DUE TO SIGNIFICANT VARIATION ALONG PARKWAY CROSS-SECTIONS, A TYPICAL CROSS-SECTION IS NOT PROVIDED.”
- H. THE FANITA RANCH SPECIFIC PLAN USES CALTRANS STANDARDS FOR HORIZONTAL AND VERTICAL DESIGN GEOMETRY BASED ON THE ASSIGNED DESIGN SPEED FOR EACH ROADWAY TYPE. UNLESS OTHERWISE NOTED STREET DESIGN SHALL CONFORM TO CITY OF SANTEE STANDARDS.
- I. EXISTING 70' ROADWAY EASEMENT.
- J. THE DESIGN SPEED OF MAGNOLIA AVENUE BETWEEN PRINCESS JOANN ROAD AND CUYAMACA STREET IS 40 MPH; HOWEVER, THE VERTICAL GRADE DOES NOT MEET THE 40 MPH DESIGN SPEED DUE TO CONDITIONS (TERRAIN CONSTRAINTS) FOR WHICH A DESIGN VARIANCE IS PROVIDED ON THE VESTING TENTATIVE MAP.

### 4.1.3 Traffic Calming Plan

The purpose of the Fanita Ranch Traffic Calming Plan is to lower the vehicle speeds on neighborhood streets without restricting access. This Traffic Calming Plan includes a set of street designs that slow and reduce traffic speeds while encouraging walkers and cyclists to share the street. The intent in implementing traffic calming measures throughout Fanita Ranch is to create streets that are valuable public spaces shared equally by all users.

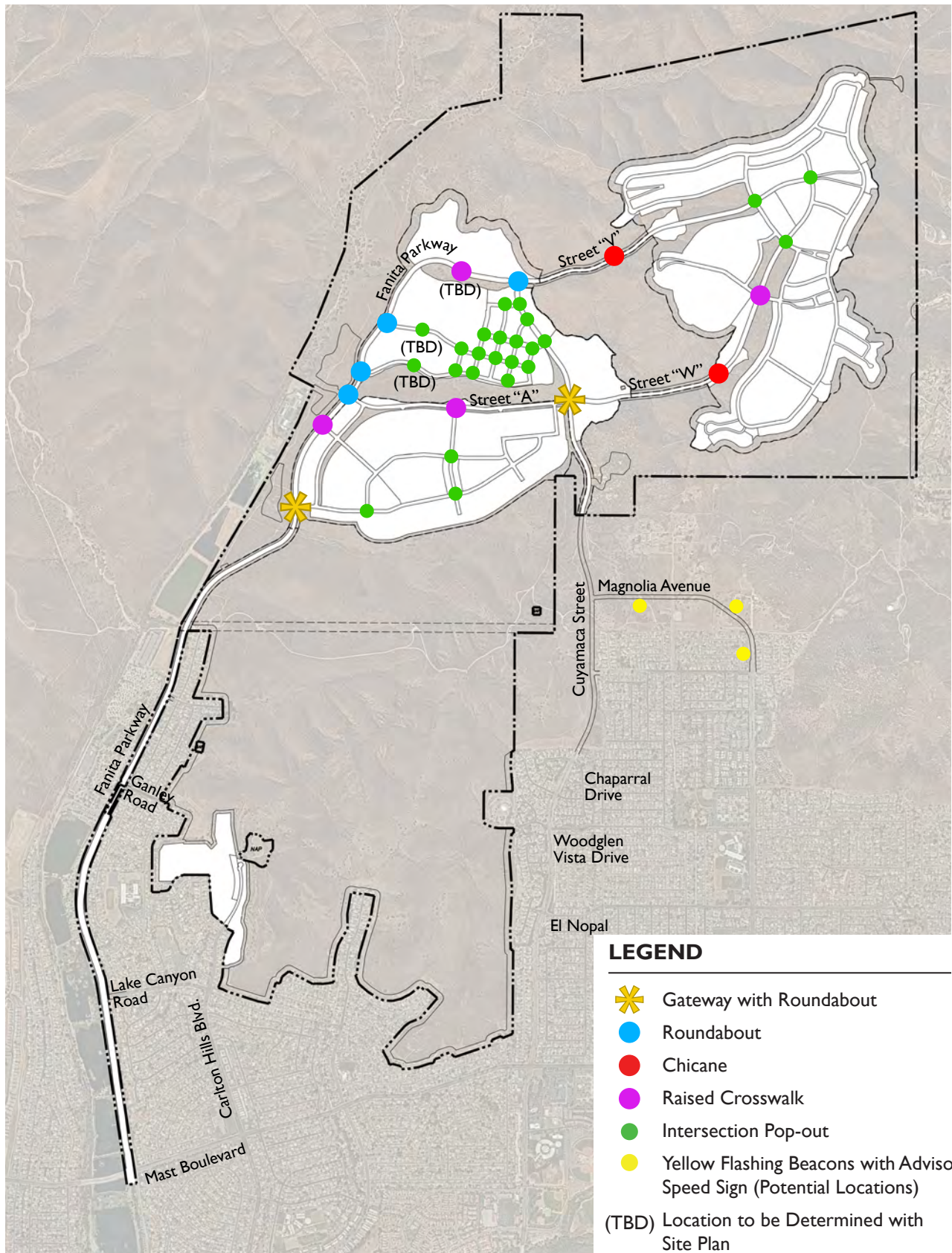
The overall goals of the Traffic Calming Plan are to:

- Improve the quality of life for residents;
- Reduce impacts of motor vehicles on local and collector streets;
- Create safe and attractive streets; and
- Create a friendly environment for pedestrians and bicyclists.

The objectives of the Traffic Calming Plan are to:

- Increase the level of respect for non-motorists;
- Create a feeling of safety for all users;
- Improve safety and convenience for all users;
- Reduce traffic accidents;
- Reduce noise;
- Provide space for non-vehicular users;
- Enhance street appearance;
- Reduce vehicular speed; and
- Reduce the need for enforcement.

Traffic calming measures are designed to physically force drivers to slow down to avoid an uncomfortable driving experience. Traffic calming measures can also be designed to achieve a desired speed limit which drivers are physically compelled to meet. Design considerations include safety, maintenance, emergency vehicle access, self-enforcement and drainage. There are a variety of traffic calming measures that are widely used throughout the United States. The Fanita Ranch Traffic Calming Plan includes the traffic calming measures described in *Table 4.2: Traffic Calming Measures* and identified in *Exhibit 4.2: Conceptual Traffic Calming Plan*. The traffic calming measures are depicted in *Exhibits 4.3.1 to 4.3.6. Exhibit 4.2: Conceptual Traffic Calming Plan* depicts the conceptual locations of proposed traffic calming measures. The final locations of these measures will be determined during final engineering.



Conceptual traffic calming measure locations only; final locations to be determined during final engineering.

**Exhibit 4.2: Conceptual Traffic Calming Plan**

not to scale

**Table 4.2: Traffic Calming Measures**

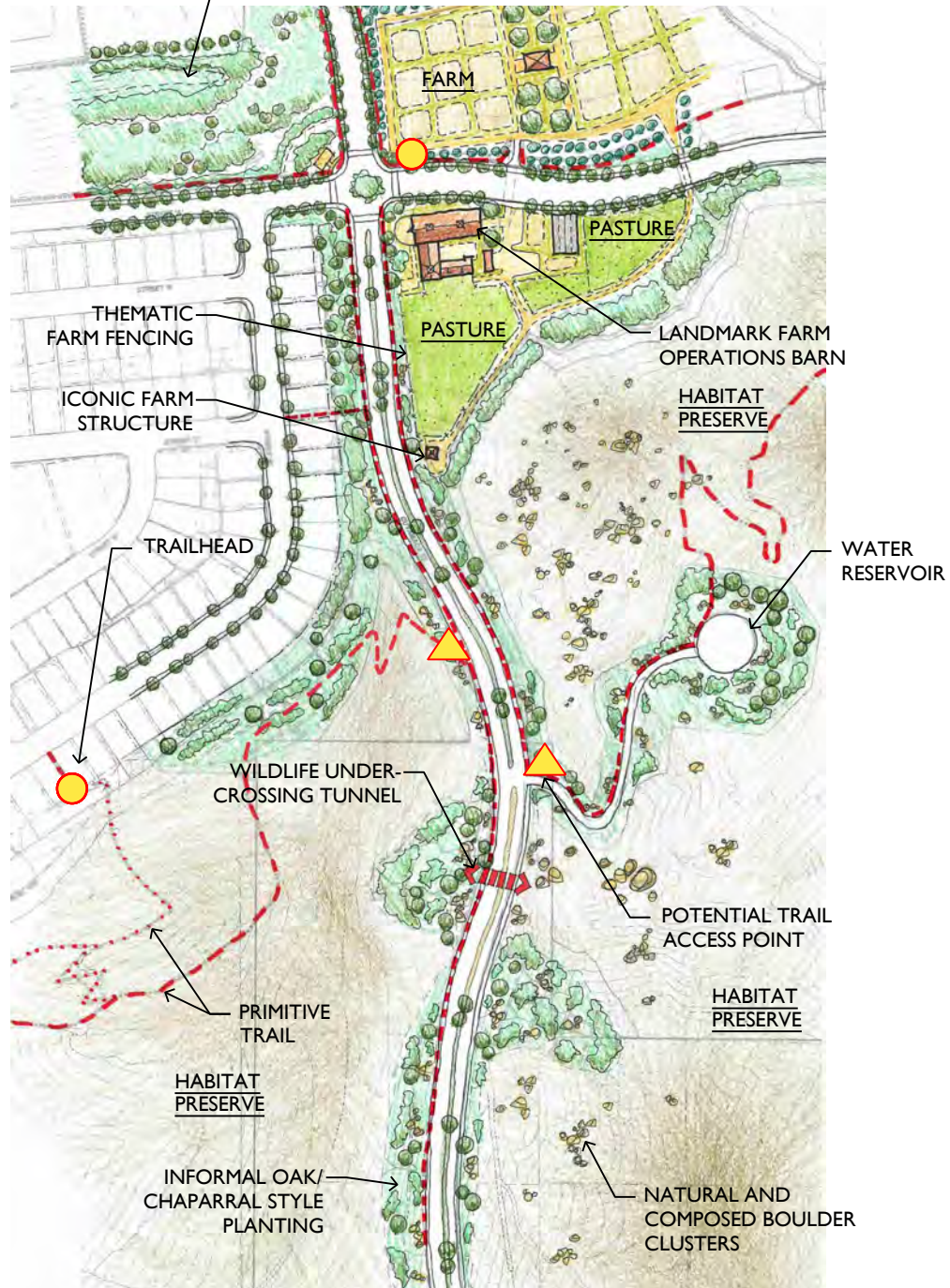
Traffic Calming Measure	Description	Benefit/Target
Gateways	Treatments include the use of signs, landscaping, special paving, and community identity monuments placed at the entrances to a neighborhood or community announcing to motorists that they are entering a community where there is a significant change in the driving environment.	<ul style="list-style-type: none"> <li>• Reduces Speed</li> <li>• Improves Safety</li> <li>• Enhances Community Aesthetics</li> </ul>
Roundabouts	Roundabouts include a raised center landscaped island, special paving, splitter islands, accessible pedestrian crossings and pedestrian/bike refuge islands	<ul style="list-style-type: none"> <li>• Reduces Speed</li> <li>• Improves Safety</li> <li>• Provides Multi-Modal Accommodations</li> <li>• Improves traffic movement</li> <li>• Replaces traffic stops/signals</li> </ul>
Chicanes	A chicane is a channelization that causes a single or series of tight turns in opposite directions on an otherwise straight section of a street. The combination of narrowed street width, a wider raised median and the serpentine path of travel slows traffic.	<ul style="list-style-type: none"> <li>• Reduces Speed</li> <li>• Improves Safety</li> </ul>
Raised Medians / Split Street	Includes raised plantable median areas at the center of a street and split streets with park or open space areas in the center.	<ul style="list-style-type: none"> <li>• Reduces Speed</li> <li>• Reduces Cut-through Volume</li> <li>• Improves Safety</li> <li>• Multi-Modal Accommodations</li> </ul>
Intersection Pop-Outs	Intersection pop-outs are curb extensions that narrow the street at intersections by widening the sidewalks at the point of crossing. They are used to make pedestrian crossings shorter and reduce the visual width of a long street. Pop-outs can also be used at intersections to create a street gateway effect, visually announcing an entrance to a neighborhood.	<ul style="list-style-type: none"> <li>• Reduces Speed</li> <li>• Improves Pedestrian Safety</li> <li>• Provides Multi-Modal Accommodations</li> </ul>
Raised Crosswalk	A raised crosswalk is essentially a speed table and is typically approximately 3.5 inches high and 22 feet long in the direction of travel with 6-foot ramps at the ends and a 10-foot field top. Final dimensions to be determined during final engineering	<ul style="list-style-type: none"> <li>• Reduces Speed</li> <li>• Enhances Pedestrian Safety</li> </ul>

**Table 4.2: Traffic Calming Measures (cont.)**

Traffic Calming Measure	Description	Benefit/Target
Lane Narrowing	Travel lanes are narrowed by reducing the paving width from standards and may include pavement markings	<ul style="list-style-type: none"> <li>• Reduces Speed</li> <li>• Improves Safety</li> <li>• Provides Multi-Modal Accommodations</li> </ul>
On-Street Bicycle Facilities	Bicycle lanes are designated through the use of signage and pavement markings identifying separate travel lanes for bicycles	<ul style="list-style-type: none"> <li>• Reduces Speed</li> <li>• Improves Safety</li> <li>• Provides Multi-Modal Accommodations</li> </ul>
On-Street Parking	Striped diagonal parking or parallel parking along one or both sides of a street	<ul style="list-style-type: none"> <li>• Reduces Speed</li> <li>• Improves Safety</li> </ul>
Yellow Flashing Beacons with Advisory Speed Signs	Yellow flashing beacons with advisory speed signs that alert drivers of steep roadway grades and to reduce speed on Magnolia Avenue	<ul style="list-style-type: none"> <li>• Reduces Speed</li> <li>• Improves Safety</li> </ul>

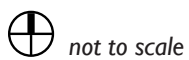


RIPARIAN ENHANCEMENT AND PRESERVATION AREA

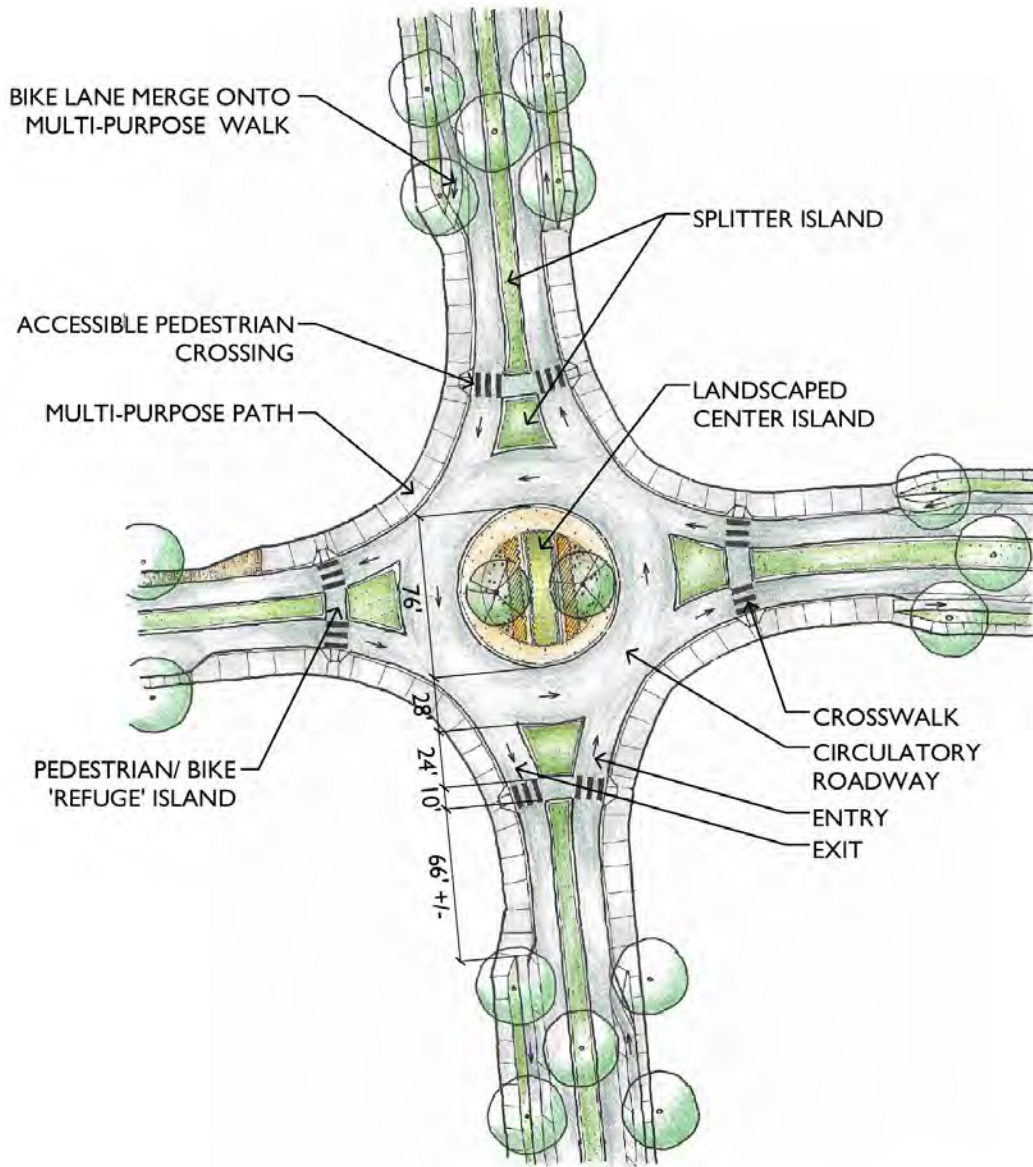


Note: Refer to Exhibit 4.13: Trails Map for detail regarding trail types and widths.

For illustrative purposes only; final design may vary.




### Exhibit 4.3.I: Conceptual Traffic Calming Gateway Design

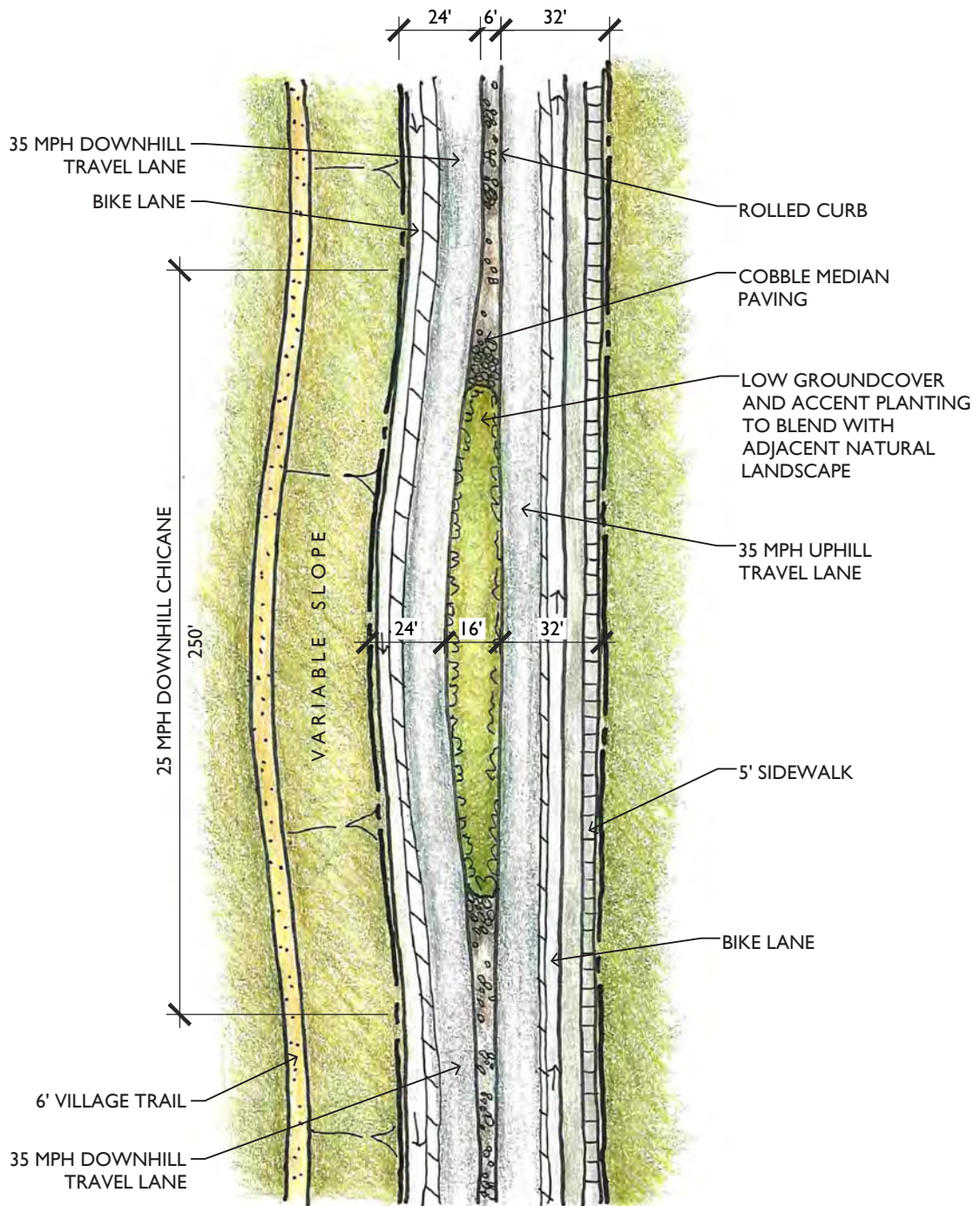


For illustrative purposes only; final design may vary.


### Exhibit 4.3.2: Conceptual Roundabout Design

 not to scale

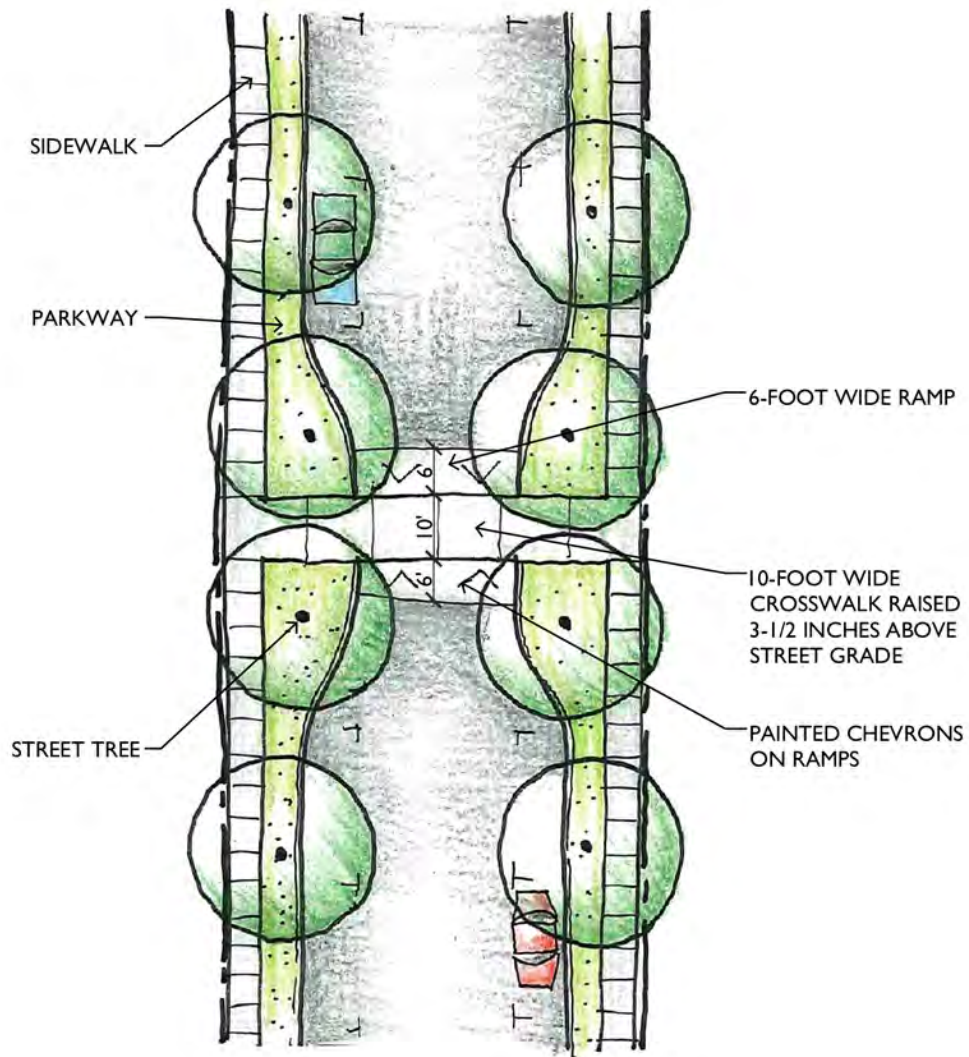




*For illustrative purposes only; final design may vary.*


 not to scale

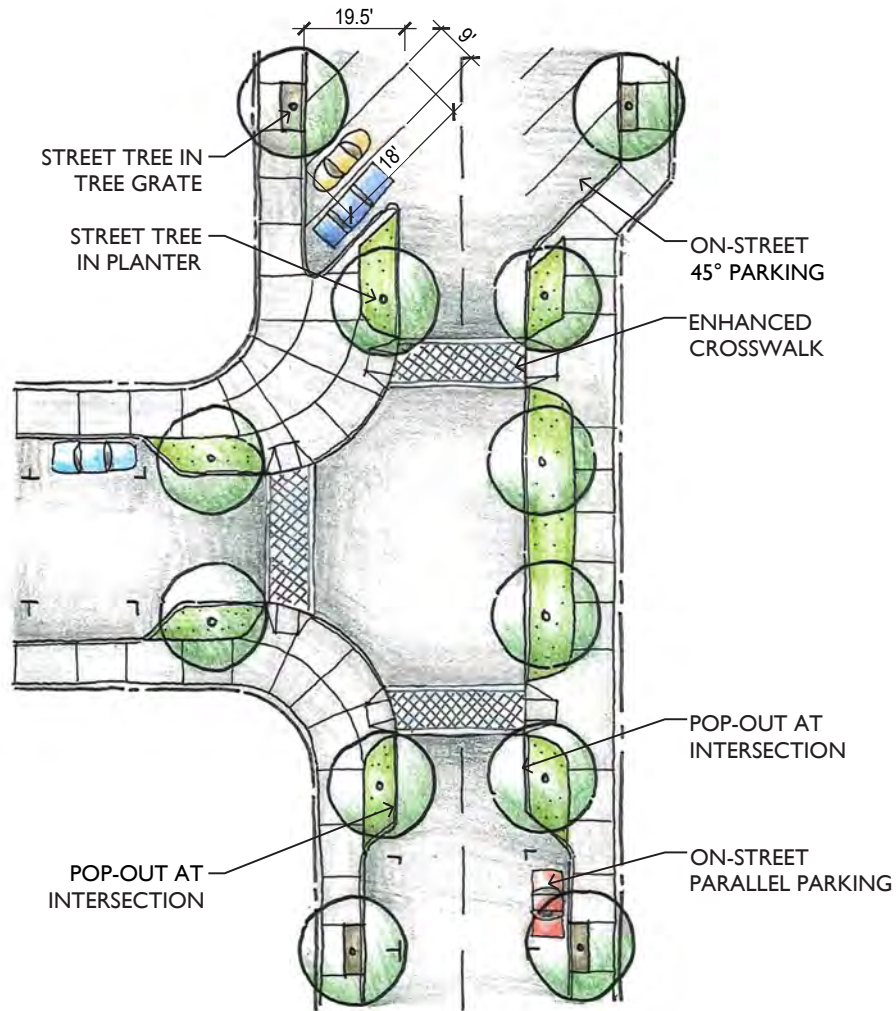
### Exhibit 4.3.3: Conceptual Chicane Design



For illustrative purposes only; final design may vary.

### Exhibit 4.3.4: Conceptual Raised Crosswalk

 not to scale

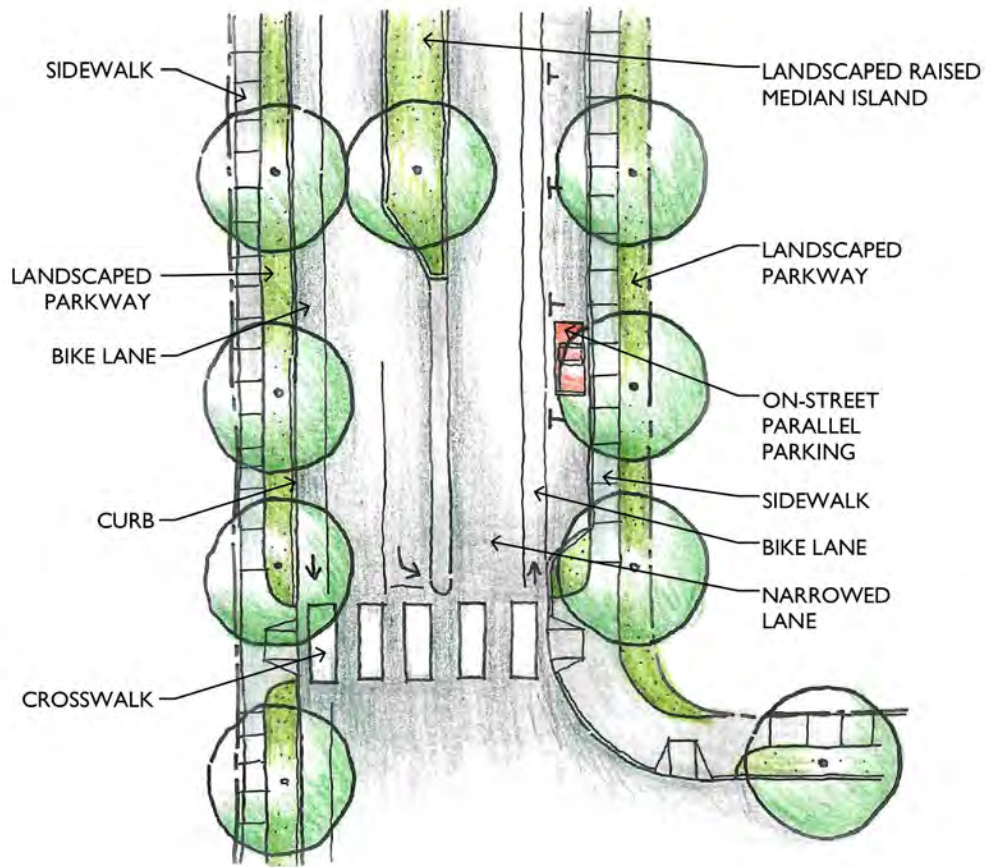


⊕ not to scale

*For illustrative purposes only; final design may vary.*


### Exhibit 4.3.5: Conceptual Intersection Pop-outs & On-Street Parking





*For illustrative purposes only; final design may vary.*

### Exhibit 4.3.6: Other Conceptual Traffic Calming Devices

 not to scale

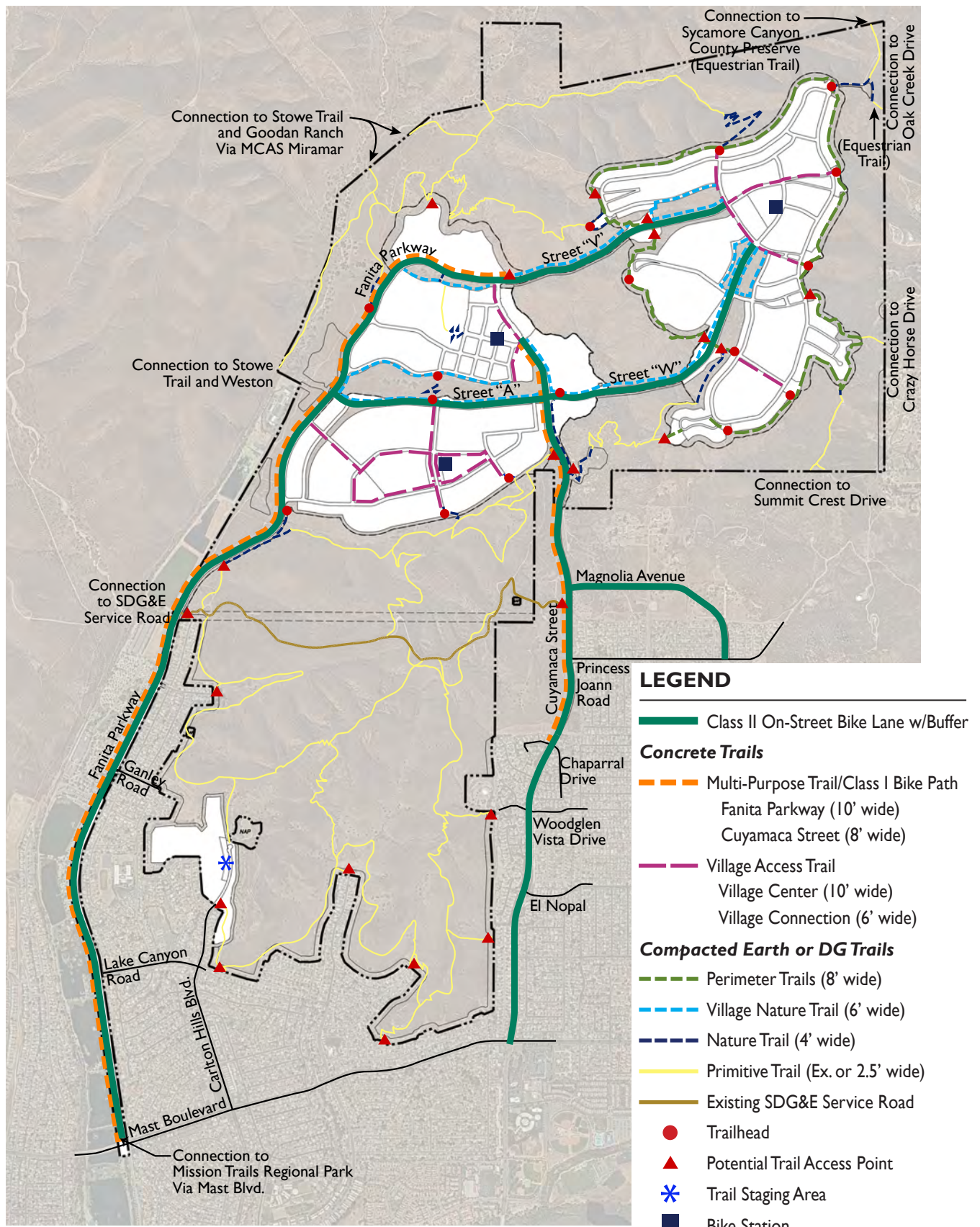
#### 4.1.4 Bicycle Circulation

Bicycle circulation throughout the community is provided through a combination of on-street bike lanes and off-street multi-purpose trails as illustrated in *Exhibit 4.4: Bicycle Circulation Plan*. The Habitat Preserve offers mountain biking trails and uses existing trail routes to the extent feasible to avoid sensitive habitat areas. Bicycle trails are designed for both recreation and to provide direct access between the Villages.

To further promote bicycling within Fanita Ranch, each Village is envisioned to provide a bike station within the Village Centers where riders have access to water and air, electric bike charging stations and a bicycle sharing system. Bicycle parking will be provided at the school site, the Farm, the Village Centers, the community park and neighborhood parks, and within all multi-family neighborhoods to further support bicycling as a viable alternative to vehicle use.








For illustrative purposes only; final design may vary.

**Exhibit 4.4: Bicycle Circulation Plan**

 not to scale

### 4.1.5 Pedestrian Circulation

Pedestrian circulation throughout the Specific Plan Area is provided through a network of sidewalks, multi-purpose trails and hiking trails as shown in *Exhibit 4.5: Pedestrian Circulation Plan*. The key to a successful pedestrian circulation system is to provide safety, connectivity and comfort.

#### A. Safety

There are several features designed into the mobility plan to calm traffic, promote pedestrian safety, and provide safe routes to the school. Traffic calming measures utilized in the Specific Plan Area are discussed in *Section 4.1.3: Traffic Calming Plan*. Additional measures and advanced technologies for traffic calming may be used as part of future designs, particularly when considering pedestrian routes between the Farm and other key areas such as the school site, Village Centers and Active Adult neighborhood.

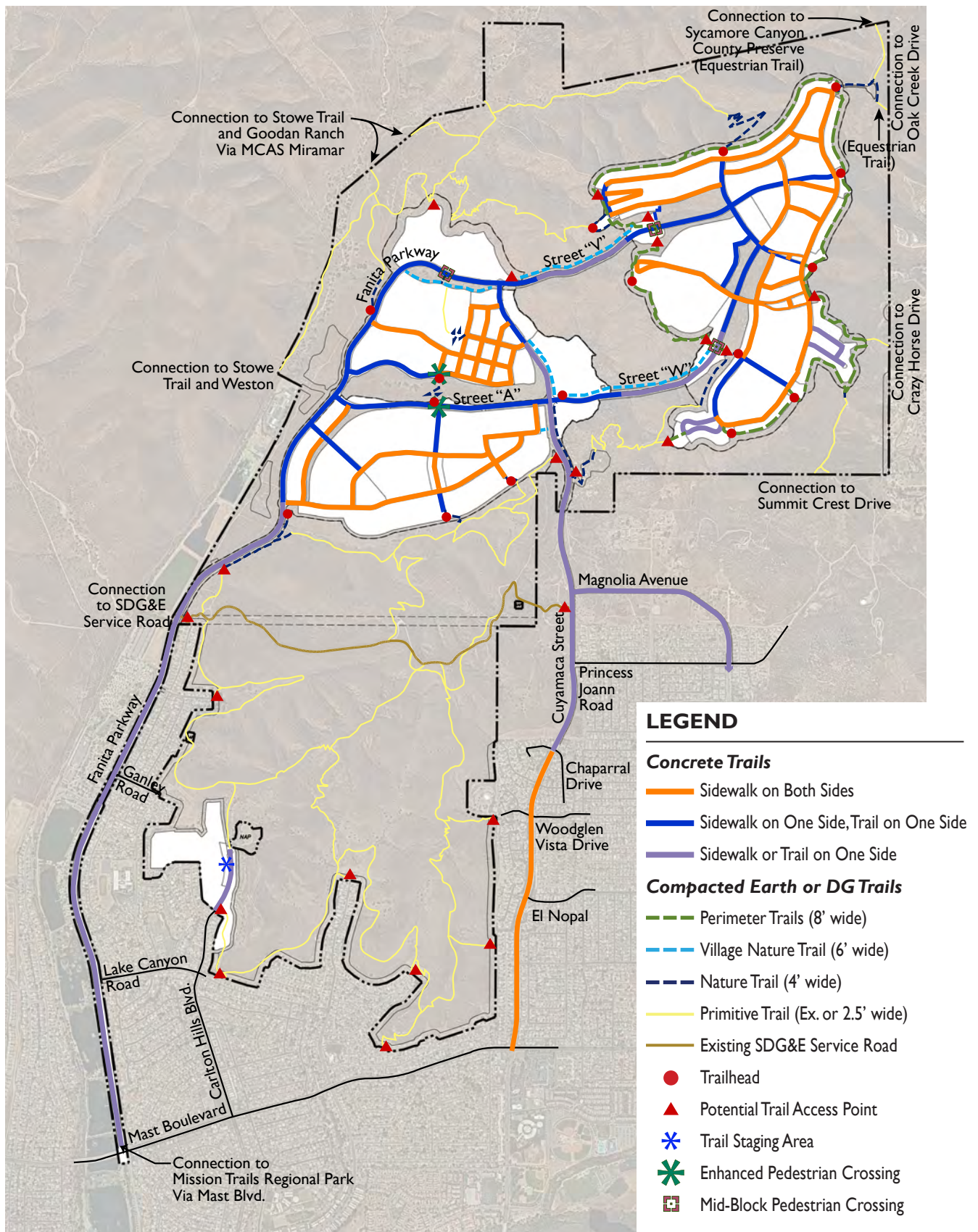
In addition to the traffic calming measures listed in *Section 4.1.3: Traffic Calming Plan*, the following pedestrian safety features are incorporated into the street designs within the community:

1. **Enhanced Pedestrian Crossings:** At intersections within Fanita Commons where significant pedestrian crossing is anticipated, crosswalks are enhanced with striping and landscape features designed to heighten the driver's awareness and indicate the presence of pedestrians, as illustrated by *Exhibit 4.6: Enhanced Pedestrian Crossings*. In Fanita Commons, curb pop-outs at intersections will be added to narrow the streets to slow traffic down and provide a shorter crossing route for pedestrians.
2. **Buffers:** Sidewalks throughout the Specific Plan Area are buffered by landscaped parkways and/or on-street parking.
3. **Mid-Block Crossings:** Where the Vineyard Village perimeter trail crosses the Residential Collectors near the Habitat Preserve, pavement texture and pedestrian-activated crosswalk warning systems will be utilized for additional pedestrian safety.

#### B. Connectivity

Walking is encouraged by providing direct connections to multiple destinations that shorten the routes and allow walking to be an efficient and viable method of travel. This is achieved by providing a variety of routes and multiple intersections offering pedestrians a wide range of options. The Fanita Ranch Pedestrian Circulation Plan provides an extensive system of interconnected sidewalks and trails that connect the Villages and destinations within the Villages.



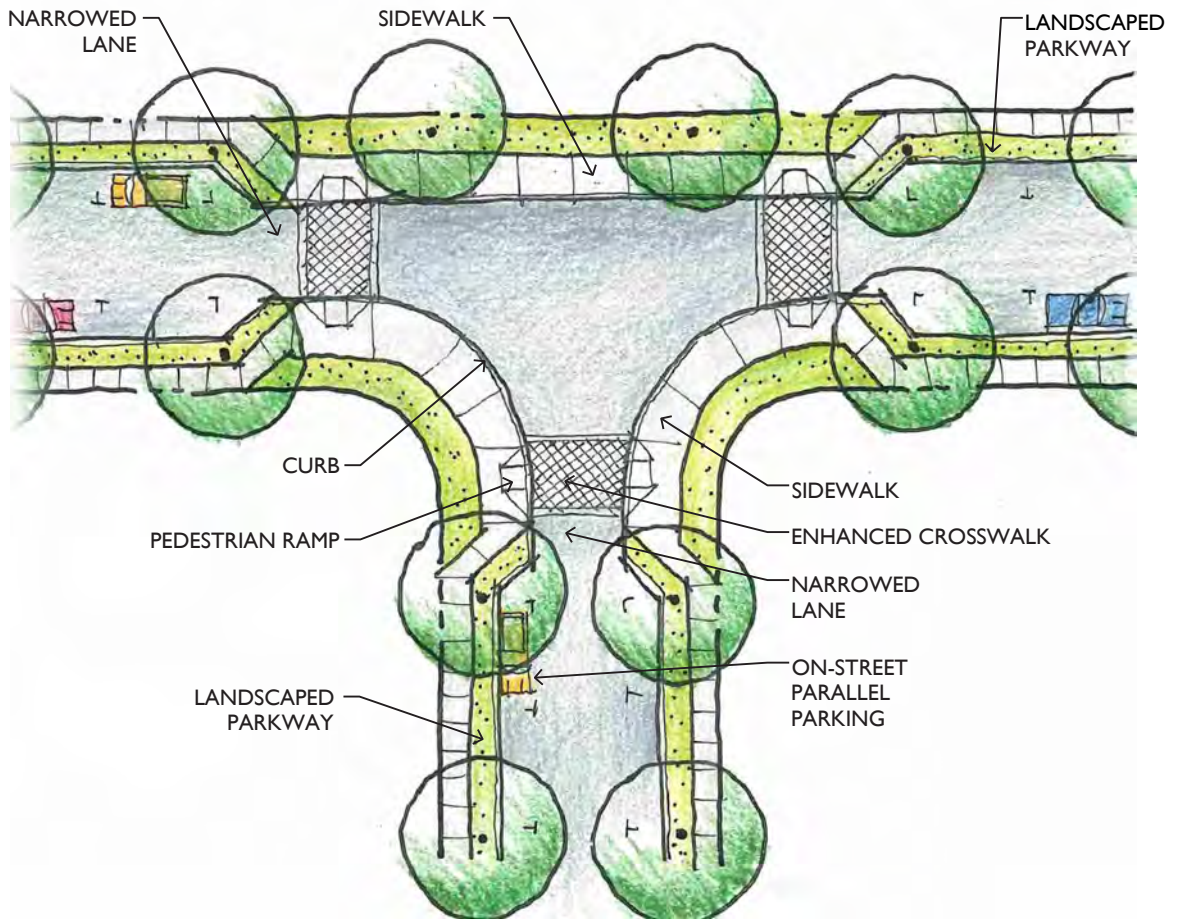


For illustrative purposes only; final design may vary.

**Exhibit 4.5: Pedestrian Circulation Plan**

⊕ not to scale





*For illustrative purposes only; final design may vary.*

### **Exhibit 4.6: Enhanced Pedestrian Crossings**

Every street within Fanita Ranch includes a sidewalk and/or multi-purpose trail to accommodate pedestrian travel. Trails along the northerly and southerly drainages also offer pedestrian connections between the school, the Farm, and the Active Adult neighborhood with minimal interruptions from vehicular traffic.

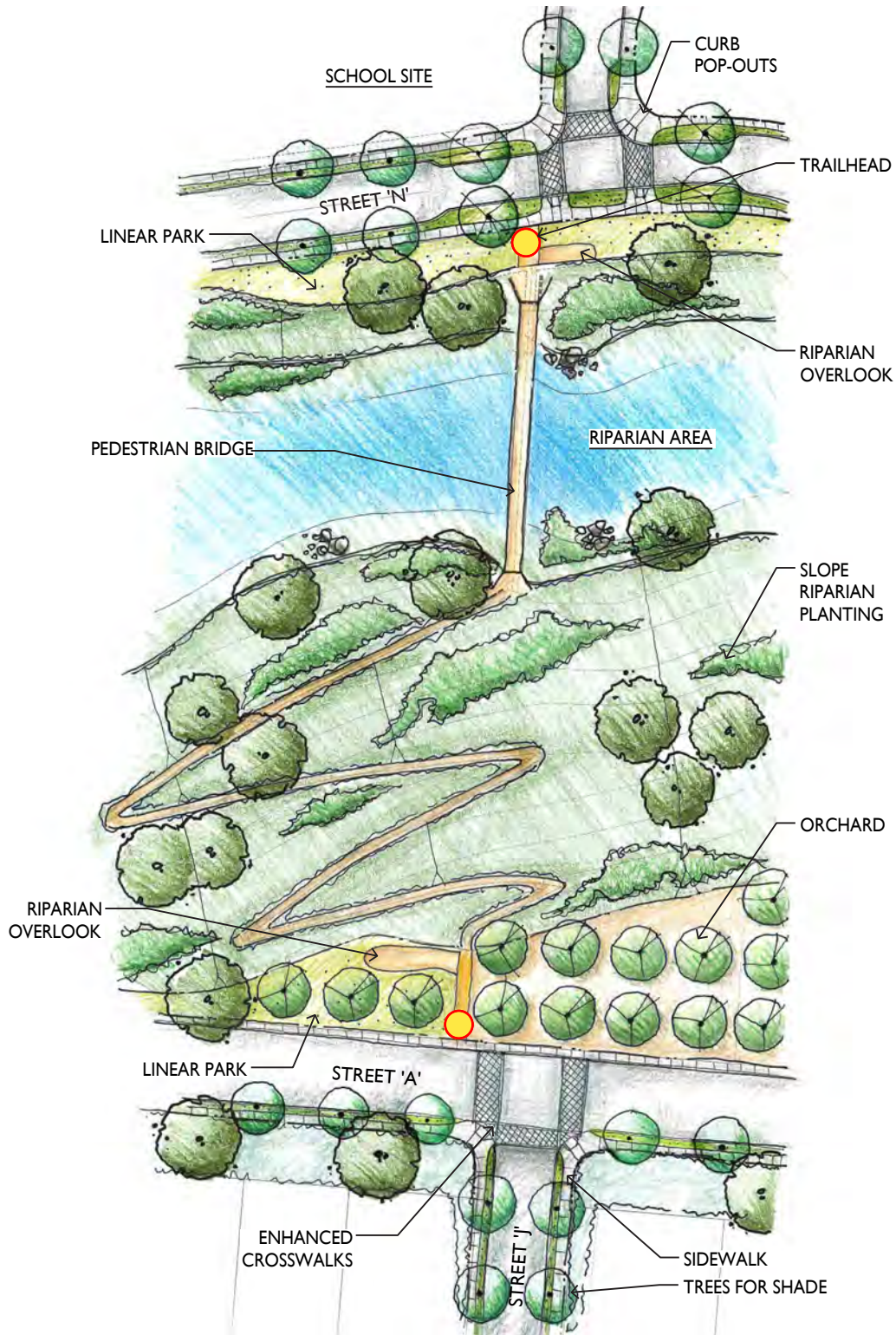
Two pedestrian bridges are envisioned to provide direct connections across the two drainages in Fanita Commons to significantly shorten the walking distance. The bridge that traverses the northerly drainage provides convenient access between the Active Adult neighborhood and the Community Park. The bridge traversing the southerly drainage connects the Orchard Village to the school, Community Park and Fanita Commons. As illustrated in *Exhibit 4.7: Southerly Bridge Crossing Detail*, the southerly bridge and its associated landing areas provide a viewing platform for observing the riparian habitat.



Trails within open space areas provide connectivity between the Villages. In addition to linking the community, the trails are also excellent locations for residents to explore the outdoors and improve their health, to learn about the natural surroundings, and to learn about and experience farming and food production. Trails within open space areas are designed to achieve the following:


1. Connect trails within Fanita Ranch to the adjacent regional trails and open space, which are described below and shown on *Exhibit 4.8: Regional Trail Context*. Fanita Ranch is a critical link to the regional trail system. Important regional trail connections are depicted in *Exhibit 4.5: Pedestrian Circulation Plan* and *Exhibit 4.13, Trails Map*.
  - a. Stowe Trail: This historic trail follows the western boundary of the Specific Plan Area from the north end of the Padre Dam Municipal Water District (PDMWD) property to the northwestern corner of the Specific Plan Area. The trail connects to the Goodan Ranch / Sycamore Canyon County Preserve.
  - b. San Diego River Park Trail/Santee River Park: An existing river park trailhead is located on Carlton Hills Boulevard, approximately ½-mile south of the south terminus of the proposed Fanita Parkway multi-purpose trail (Mast Park West trail). The trailhead can be reached by proposed sidewalks and bike lanes on Fanita Parkway, Carlton Oaks Drive and Carlton Hills Boulevard. The river park trails can also be reached on Cuyamaca Street by the sidewalk and bike lanes approximately one mile south of the southern terminus of Cuyamaca Street multi-purpose trail.



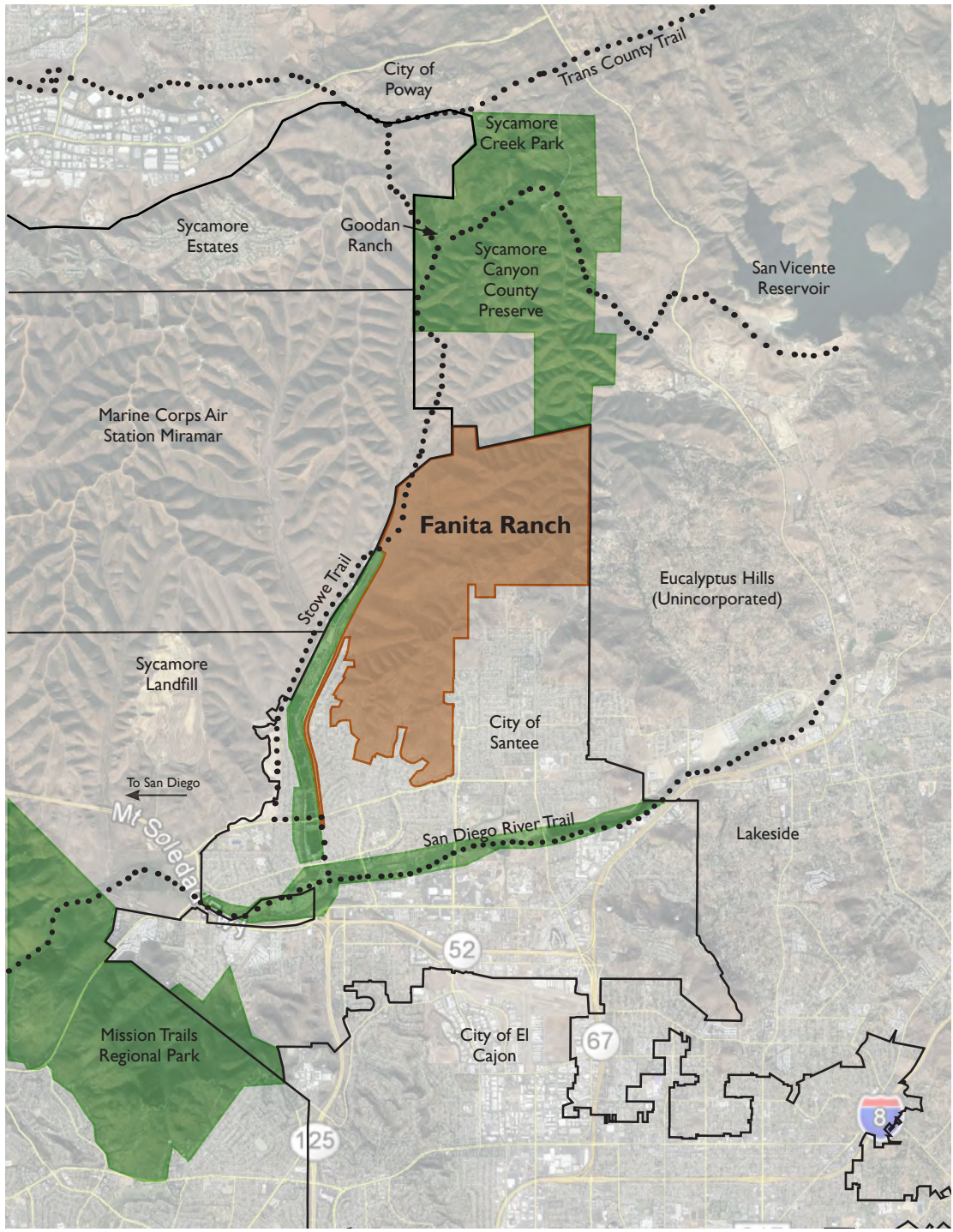


*For illustrative purposes only; final design may vary.*

### Exhibit 4.7: Southerly Bridge Crossing Detail

 not to scale





**LEGEND**

- Fanita Ranch
- Regional Parks and Preserves (Boundaries are approximate)
- Regional Trail
- Municipal Boundaries

**Exhibit 4.8: Regional Trail Context**

*not to scale*

- c. Goodan Ranch / Sycamore Canyon County Preserve: In the northeastern corner of the Specific Plan Area, a connection is made to an existing equestrian trail that leads northwards to the Goodan Ranch / Sycamore Canyon County Preserve.
  - d. Mission Trails Regional Park: The East Fortuna Staging Area of the park is located approximately 1 ½ miles west of the intersection of Fanita Parkway and Mast Boulevard, at the western terminus of Mast Boulevard. This staging area provides parking, picnicking and access to more than 60 miles of trails within the park.
2. Provide for public access to existing primitive trails within the Habitat Preserve.
  3. Carefully coordinate trail locations to minimize conflicts with sensitive habitat areas by utilizing existing trails and dirt roads, and providing signage, well-defined trail markers, fencing and community education to protect habitat areas.
  4. Establish a community-wide hiking, biking, walking, educational and recreational trail system, called “AgMeander” (see *Section 7.3.5: AgMeander* of the Specific Plan), that connects agricultural and/or environmental locations throughout the community.

### **C. Comfort**

Pedestrian comfort requires more than just safety. It requires creating a comfortable and enjoyable walking experience to encourage walking as a preferred means of mobility. Design guidelines contained in *Chapter 5: Landscape Architecture, Community Design & Outdoor Lighting Design Plan* and *Chapter 6: Architectural Design Guidelines* focus on creating comfortable, convenient and safe pedestrian pathways through architectural and landscape design. Such strategies include careful placement of parking to reduce visual impacts to streets, building placement and design that define street edges and create pedestrian scale, and landscaping and street furniture that support pedestrian comfort. Street trees are planted along all streets to provide shaded sidewalks and roadways, as well as reduce glare from parked cars.

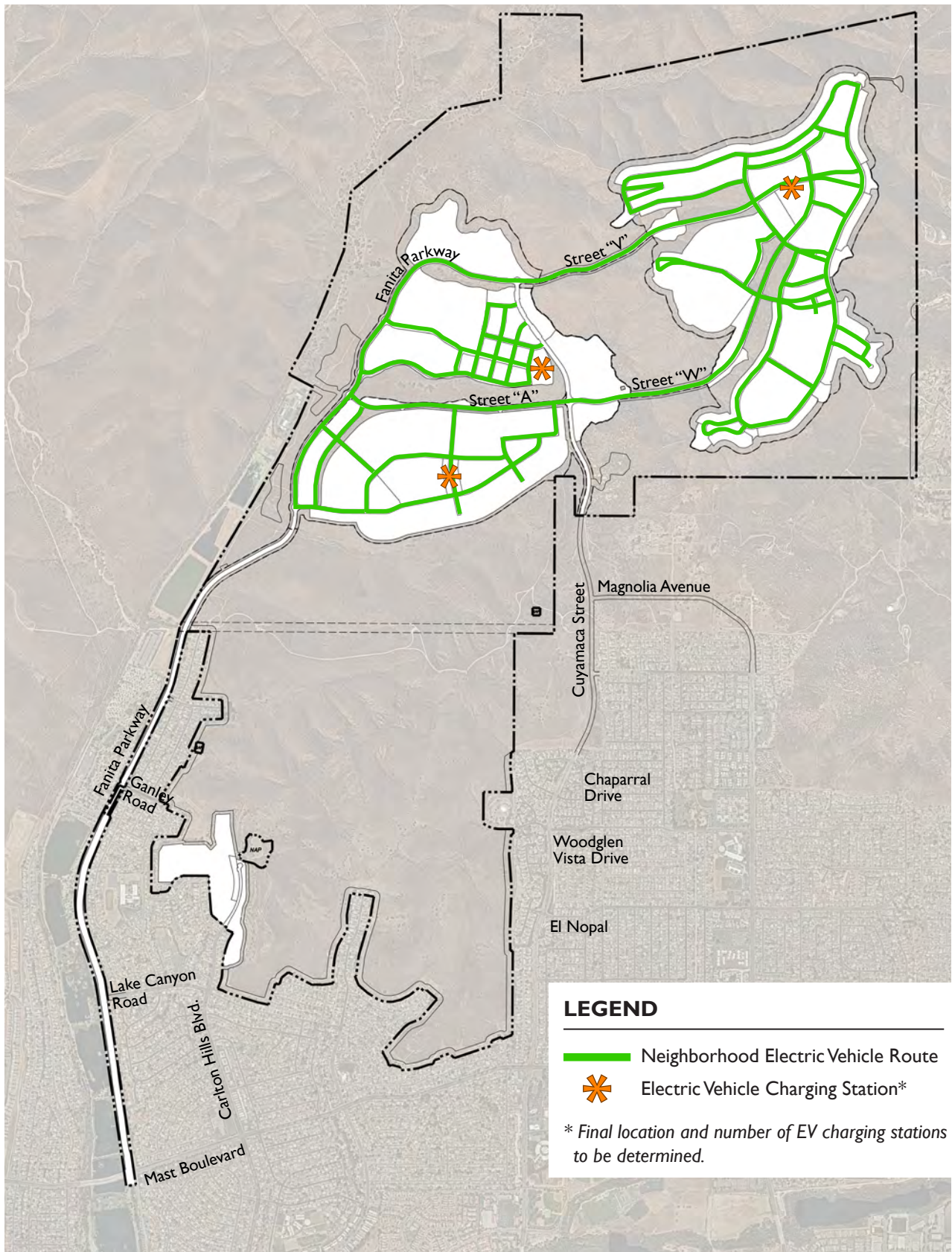


### 4.1.6 Alternative Vehicles & Ride-sharing

Neighborhood Electric Vehicles (NEVs) are small, vehicles typically designed to travel at speeds of more than 20 miles per hour and not more than 25 miles per hour. NEVs are built to specific federal vehicle standards by licensed manufacturers and carry a Federal Certification Safety label. According to the California Vehicle Code, NEVs may be operated on public streets where the speed limit is 35 miles per hour or less. In Fanita Ranch, this includes the roadways within and between the Villages that are indicated in *Exhibit 4.9: Alternative Vehicle Circulation Plan*. Tractors and all-terrain vehicles associated with the operation and maintenance of the agriculture areas are also permitted on these low-speed roadways.

Car-sharing and electric vehicle (EV) use will be supported and encouraged through the provision of passenger loading areas, charging stations and dedicated preferred parking locations in each Village Center. EV chargers will be installed in all homes within the Low Density Residential land use designation areas, some homes in the Medium Density Residential, Active Adult and Village Center land use designation areas, as well as within the parking lots of commercial projects in the Village Centers (see Fanita Ranch EIR Appendix H, Greenhouse Gas Analysis). As technologies evolve, additional community-wide features may be incorporated into the Specific Plan Area in support of the Sustainable Santee Plan.





For illustrative purposes only; final design may vary.

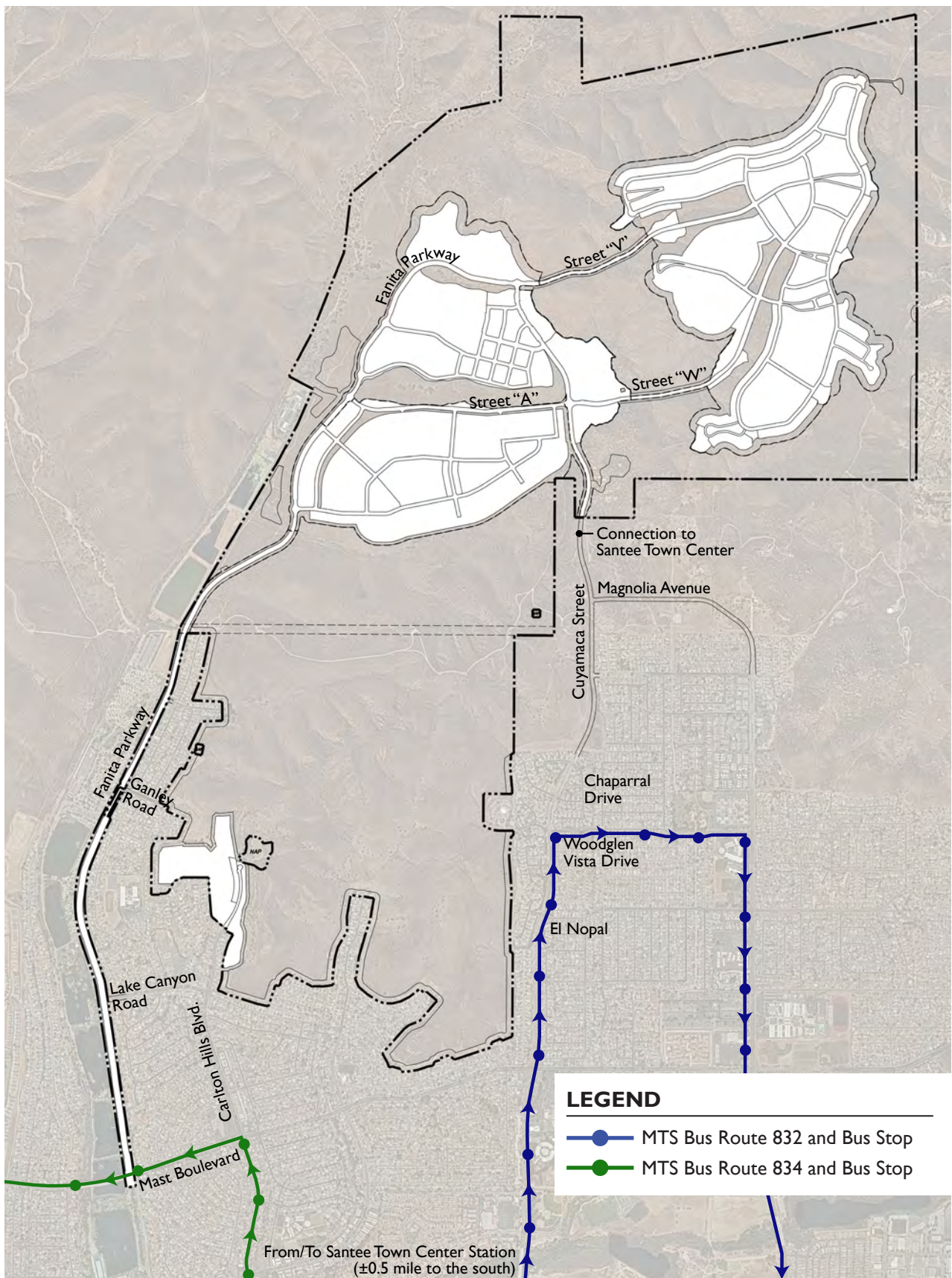
⊕ not to scale

**Exhibit 4.9: Alternative Vehicle Circulation Plan**

#### **4.1.7 Transit**

The Metropolitan Transit System (MTS) provides transit services within the City of Santee. MTS operates two local bus routes in the vicinity of Fanita Ranch. Existing MTS Route 832 operates on Cuyamaca Street, Woodglen Vista Drive and Magnolia Avenue, and existing MTS Route 834 operates on Mast Boulevard and Carlton Hills Boulevard. Both existing local bus routes connect to the Sycuan Green Trolley Line at a transit station located in the Santee Town Center. MTS does not have plans to extend local bus services to Fanita Ranch; however, if MTS expands local bus service into Fanita Ranch in the future, local bus stops could be accommodated within the Village Centers. See *Exhibit 4.10, Conceptual Transit Plan* for the location of existing MTS local bus routes.





**LEGEND**  
 ● MTS Bus Route 832 and Bus Stop  
 ● MTS Bus Route 834 and Bus Stop

*For illustrative purposes only; final design may vary.*

**Exhibit 4.10: Conceptual Transit Plan**

⊕ not to scale

## 4.2 Street Corridor & Landscape Standards

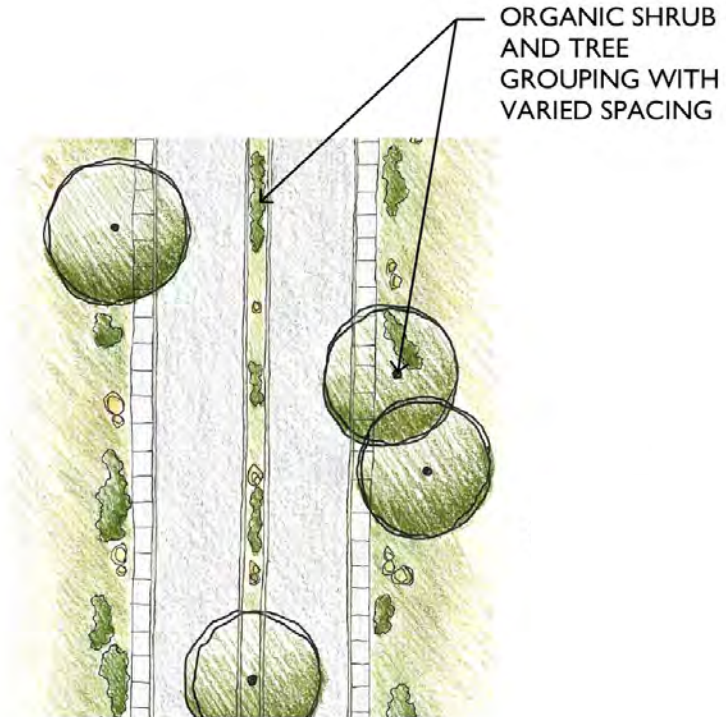
Thoughtful planning and design of the street corridors and their landscape treatments is essential to creating community and Village identity. The Fanita Ranch street corridor and landscape treatments are designed in either informal or formal styles as illustrated in *Exhibit 4.11, Planting Styles*.

Informal planting is characterized by varied tree and shrub spacing and organic or naturalistic plant grouping shapes. Informal landscape treatment is utilized where the street is either in or adjacent to the Habitat Preserve or other informal landscape areas. Informal planting schemes will be implemented on Fanita Parkway and Gateway, Cuyamaca Street and Gateway, Street “A” along the southerly side of the southerly riparian area and portions of Streets “W” and “V” where they cross the Habitat Preserve and at the basins.

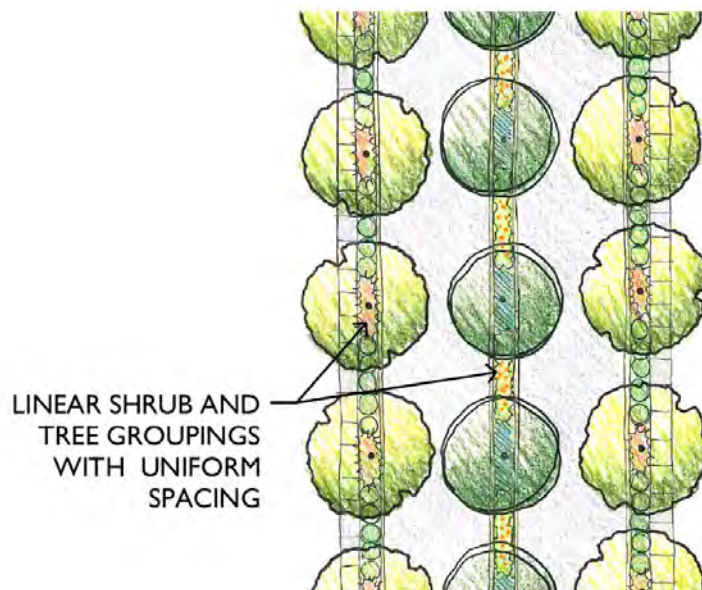
The formal planting style is characterized by uniform plant spacing and linear or geometric shaped plant groupings. Formal landscape planting is utilized for the off-site extension of Magnolia Avenue, streets in Fanita Commons, interior residential streets and private residential driveways.

The Fanita Ranch community-wide street sections and corresponding landscape treatments are depicted in *Exhibits 4.12.1 through 4.12.8, 4.12.10, 4.12.11 and 4.12.13. Exhibits 4.12.12, 4.12.14 and 4.12.16 through 4.12.21* represent Village-specific streets. Their plant palettes are described in detail in *Chapter 5: Landscape Architecture, Community Design & Outdoor Lighting Design Plan*.





Informal Planting Style



Formal Planting Style

*For illustrative purposes only; final design may vary.*

**Exhibit 4.11: Planting Styles**

### 4.2.1 Fanita Parkway - 4-Lane Parkway/ Major Arterial (Mast Boulevard to Lake Canyon Road)

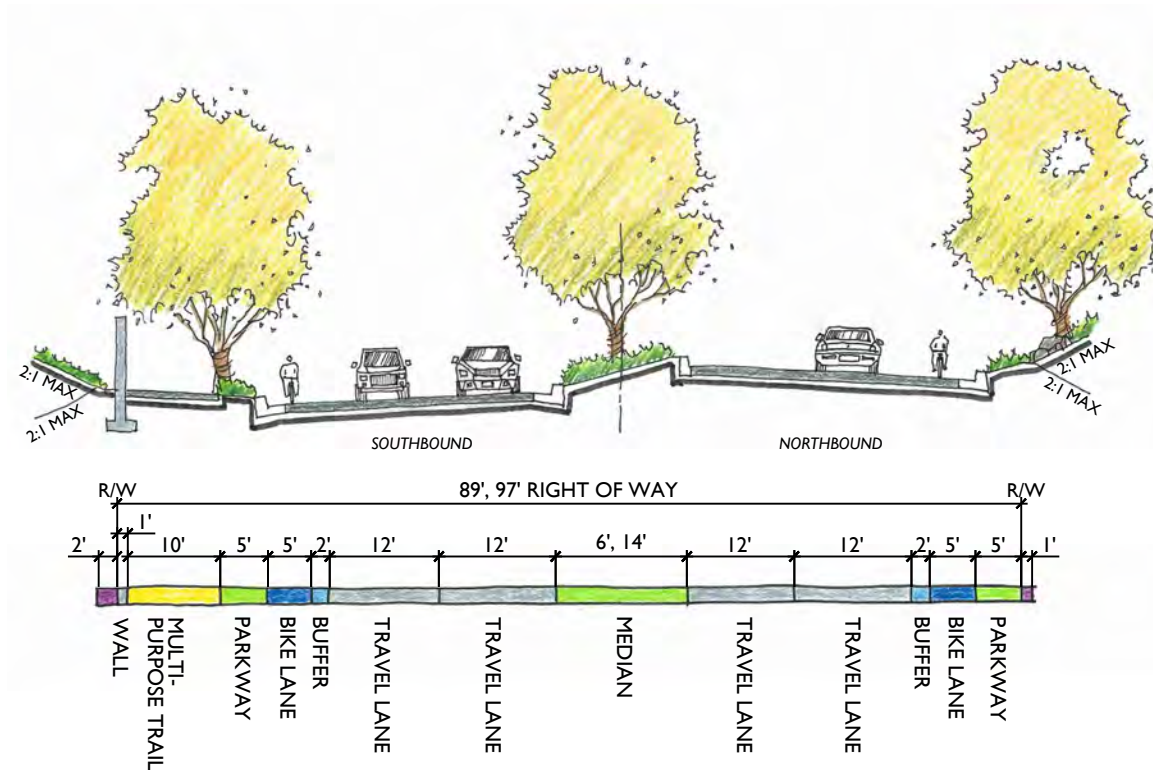
Between Mast Boulevard and Lake Canyon Road, Fanita Parkway will be widened from a 2-lane road with no median to a 4-lane divided road with a landscaped median as illustrated in *Exhibit 4.12.1: Fanita Parkway - 4-Lane Parkway/Major Arterial (Mast Boulevard to Lake Canyon Road)*. This roadway section includes bike lanes on both sides and a multi-purpose trail on the west side of the street. Parking is limited to emergency vehicles.



**Key Map**  
not to scale

Design Standards <sup>1</sup>	
Volume	15,000 - 40,000 Average Daily Trips
Design Speed	50 mph
Modes	<ul style="list-style-type: none"> <li>• Vehicles</li> <li>• Bicycles</li> <li>• Pedestrians</li> </ul>
Dimensions	
Right-of-Way Width	97 feet (89 feet where median width is reduced)
Curb-to-Curb Width	31 feet in each direction
Median	6 feet, 14 feet wide (width varies <sup>2</sup> ), raised and landscaped
Landscape Scheme	
Style	Informal “Riparian” parkway and median planting
Tree Spacing	40 - 500 feet on center
Roadside FMZ	50 feet both sides

1. For full engineering street design criteria, refer to *Table 4.1: Street Design Criteria*. (Tentative Map Street Section No. 1)  
 2. Median width may be reduced to 6’ in the vicinity of wetland and/or biological impacts, provided the required turn pockets function properly. Parkway and median may have up to a 4:1 slope where shown on plans.



## Landscape Palette:

### Trees

- PLATANUS RACEMOSA - California Sycamore
- KOELREUTERIA BIPINNATA - Chinese Flame Tree
- ARBUTUS X 'MARINA' - Arbutus

### Shrubs / Perennials

- CEANOTHUS SP. - California Lilac
- CISTUS SP. - Rockrose
- PHORMIUM TENAX - New Zealand Flax

### Groundcovers

- CEANOTHUS G. HORIZONTALIS - Carmel Creeper
- LANTANA MONTEVIDENSIS - Trailing Lantana
- MYOPORUM PARVIFOLIUM 'PINK' - Pink Myoporum

## Exhibit 4.12.1: Fanita Parkway - 4-Lane Parkway/Major Arterial (Mast Boulevard to Lake Canyon Road)

### 4.2.2 Fanita Parkway - 3-Lane Parkway (Lake Canyon Road to Ganley Road)

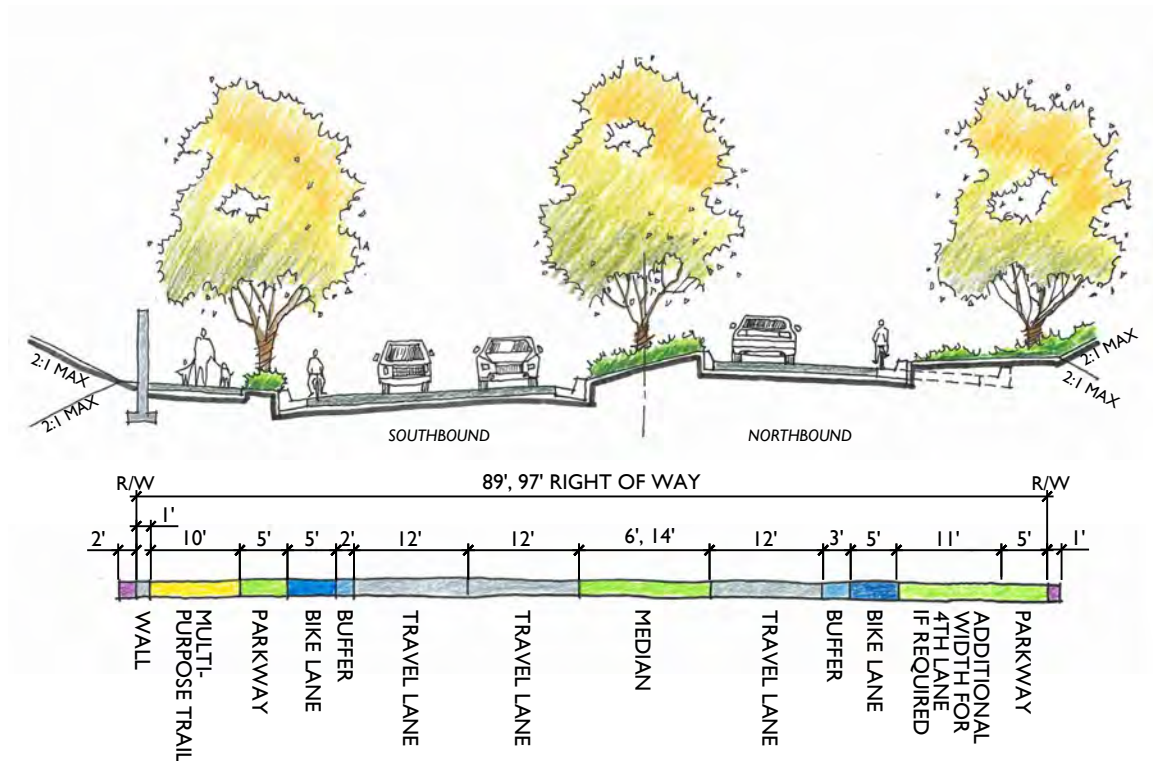
Fanita Parkway transitions to a 3-lane parkway between Lake Canyon Road and Ganley Road. The west (southbound) side of the roadway maintains two travel lanes, while the east (northbound) side consists of one travel lane. A landscaped median divides both sides of the road as shown in *Exhibit 4.12.2: Fanita Parkway - 3-Lane Parkway (Lake Canyon Road to Ganley Road)*. This roadway section includes bike lanes on both sides and a multi-purpose trail on the west side of the street.



**Key Map**  
not to scale

Design Standards <sup>1</sup>	
Volume	15,000 - 40,000 Average Daily Trips
Design Speed	50 mph
Modes	<ul style="list-style-type: none"> <li>• Vehicles</li> <li>• Bicycles</li> <li>• Pedestrians</li> </ul>
Dimensions	
Right-of-Way Width	97 feet (89 feet where median width is reduced)
Curb-to-Curb Width	<ul style="list-style-type: none"> <li>• West side (southbound): 31 feet</li> <li>• East side (northbound): 20 feet</li> </ul>
Median	6 feet, 14 feet wide (width varies <sup>2</sup> ), raised and landscaped
Landscape Scheme	
Style	Informal “Riparian” parkway and median planting
Tree Spacing	40 - 500 feet on center
Roadside FMZ	50 feet both sides

1. For full engineering street design criteria, refer to *Table 4.1: Street Design Criteria*. (Tentative Map Street Section No. 1a)  
 2. Median width may be reduced to 6’ in the vicinity of wetland and/or biological impacts, provided the required turn pockets function properly. Parkway and median may have up to a 4:1 slope where shown on plans.



## Landscape Palette:

### Trees

- PLATANUS RACEMOSA - California Sycamore
- KOELREUTERIA BIPINNATA - Chinese Flame Tree
- ARBUTUS X 'MARINA' - Arbutus

### Shrubs / Perennials

- CEANOTHUS SP. - California Lilac
- CISTUS SP. - Rockrose
- PHORMIUM TENAX - New Zealand Flax

### Groundcovers

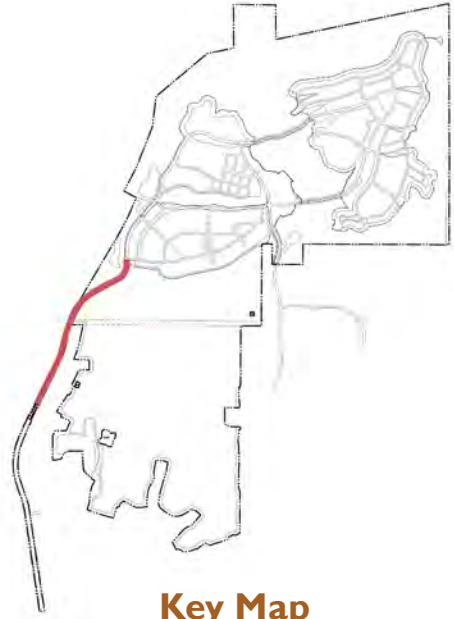
- CEANOTHUS G. HORIZONTALIS - Carmel Creeper
- LANTANA MONTEVIDENSIS - Trailing Lantana
- MYOPORUM PARVIFOLIUM 'PINK' - Pink Myoporum

## Exhibit 4.12.2: Fanita Parkway - 3-Lane Parkway (Lake Canyon Road to Ganley Road)



### 4.2.3 Fanita Parkway - 2-Lane Parkway Type II (Ganley Road to Street “E”)

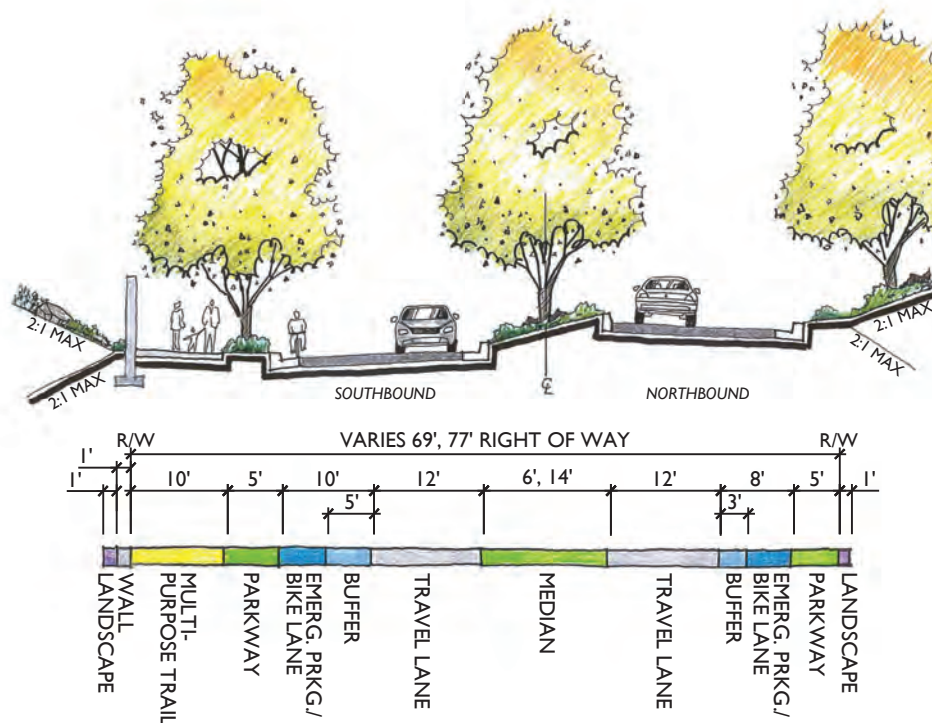
Fanita Parkway transitions to a 2-lane road with a median from Ganley Road to Street “E” in Orchard Village. The road section includes one 12-foot travel lane, 5-foot bike lanes, and a 3- to 5-foot bike lane buffer in each direction. The 10-foot multi-purpose trail continues along the west side of the street and is separated from the road by a 6-foot landscaped parkway. A 5-foot landscape area and no sidewalk are proposed on the east side, as illustrated in *Exhibit 4.12.3: Fanita Parkway - 2-Lane Parkway Type II (Ganley Road to Street “E”)*.



**Key Map**  
not to scale

Design Standards <sup>1</sup>	
Volume	5,000 - 15,000 Average Daily Trips
Design Speed	40 mph
Modes	<ul style="list-style-type: none"> <li>• Vehicles</li> <li>• Bicycles</li> <li>• Pedestrians</li> </ul>
Dimensions	
Right-of-Way Width	77 feet (69 feet where median width is reduced)
Curb-to-Curb Width	<ul style="list-style-type: none"> <li>• West side (southbound): 22 feet</li> <li>• East side (northbound): 20 feet</li> </ul>
Median	6 feet, 14 feet wide (width varies <sup>2</sup> ), raised and landscaped
Landscape Scheme	
Style	Informal “Riparian” parkway and median planting
Tree Spacing	40 - 500 feet on center
Roadside FMZ	50 feet both sides

1. For full engineering street design criteria, refer to *Table 4.1: Street Design Criteria*. (Tentative Map Street Section No. 4)  
 2. Median width may be reduced to 6’ in the vicinity of wetland and/or biological impacts, provided the required turn pockets function properly. Parkway and median may have up to a 4:1 slope where shown on plans.



## Landscape Palette:

### Trees

- PLATANUS RACEMOSA - California Sycamore
- KOELREUTERIA BIPINNATA - Chinese Flame Tree
- ARBUTUS X 'MARINA' - Arbutus

### Shrubs / Perennials

- CEANOTHUS SP. - California Lilac
- CISTUS SP. - Rockrose
- PHORMIUM TENAX - New Zealand Flax

### Groundcovers

- CEANOTHUS G. HORIZONTALIS - Carmel Creeper
- LANTANA MONTEVIDENSIS - Trailing Lantana
- MYOPORUM PARVIFOLIUM 'PINK' - Pink Myoporum

## Exhibit 4.12.3: Fanita Parkway - 2-Lane Parkway Type II (Ganley Road to Street "E")

### 4.2.4 Fanita Parkway - 2-Lane Parkway Type III (Street “E” to Street “N”)

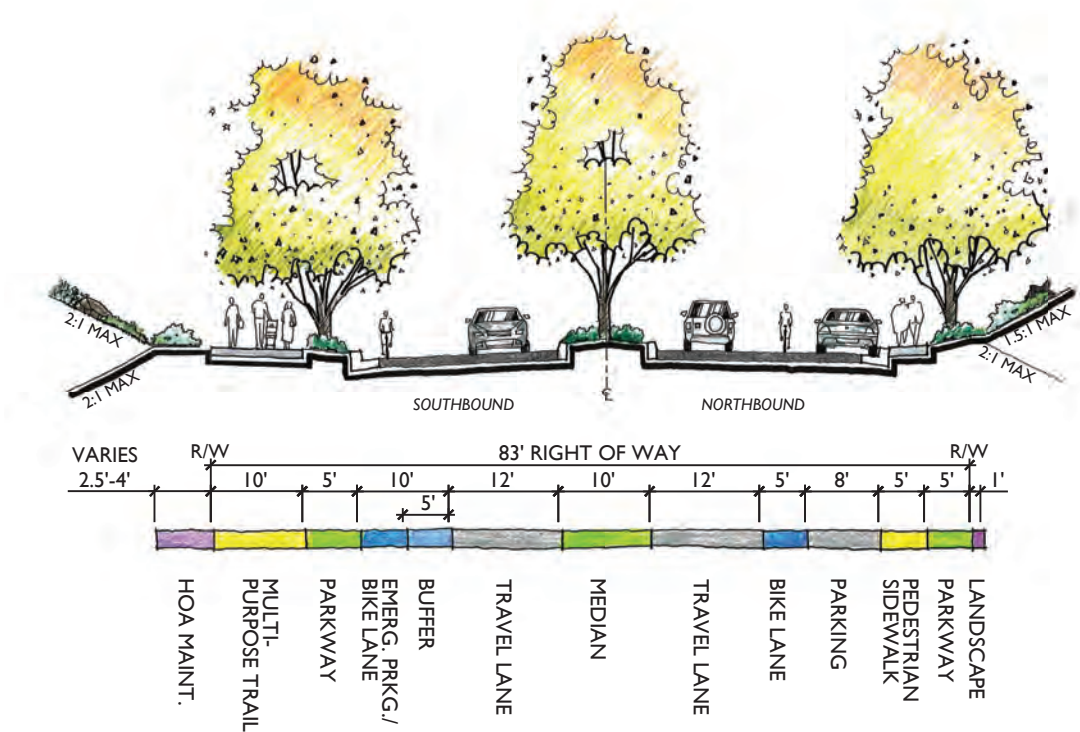
Fanita Parkway intersects with Street “E” in Orchard Village, continues northward across the southerly drainage and intersects with Street “N” in Fanita Commons. This 83-foot wide section consists of a 2-lane road divided by a 10-foot raised median. The 10-foot multi-purpose trail continues along the west side of the street. On-street parallel parking occurs on the east side of the street and bike lanes are provided on both sides of the street, as illustrated in *Exhibit 4.12.4: Fanita Parkway - 2-Lane Parkway Type III (Street “E” to Street “N”)*.



**Key Map**  
not to scale

Design Standards <sup>1</sup>	
Volume	5,000 - 15,000 Average Daily Trips
Design Speed	40 mph (20 mph in vicinity of roundabout)
Modes	<ul style="list-style-type: none"> <li>• Vehicles</li> <li>• NEVs</li> <li>• Bicycles</li> <li>• Pedestrians</li> </ul>
Dimensions	
Right-of-Way Width	83 feet
Curb-to-Curb Width	<ul style="list-style-type: none"> <li>• West side (southbound): 22 feet</li> <li>• East side (northbound): 25 feet</li> </ul>
Median	10 feet wide, raised and landscaped
Landscape Scheme	
Style	Informal “Riparian” parkway and median planting
Tree Spacing	40 - 500 feet on center
Roadside FMZ	50 feet both sides

1. For full engineering street design criteria, refer to *Table 4.1: Street Design Criteria*. (Tentative Map Street Section No. 5)



## Landscape Palette:

### Trees

- PLATANUS RACEMOSA - California Sycamore
- KOELREUTERIA BIPINNATA - Chinese Flame Tree
- ARBUTUS X 'MARINA' - Arbutus

### Shrubs / Perennials

- CEANOTHUS SP. - California Lilac
- CISTUS SP. - Rockrose
- PHORMIUM TENAX - New Zealand Flax

### Groundcovers

- CEANOTHUS G. HORIZONTALIS - Carmel Creeper
- LANTANA MONTEVIDENSIS - Trailing Lantana
- MYOPORUM PARVIFOLIUM 'PINK' - Pink Myoporum

**Exhibit 4.12.4: Fanita Parkway - 2-Lane Parkway Type III**  
(Street "E" to Street "N")

### 4.2.5 Cuyamaca Street, Off-Site - 4-Lane Major Arterial (Mast Boulevard to Chaparral Drive)

Cuyamaca Street provides the primary entrance into Fanita Ranch. North of Mast Boulevard, existing segments of the roadway will be improved to match the street section illustrated in *Exhibit 4.12.5: Cuyamaca Street, Off-Site - 4-Lane Major Arterial (Mast Boulevard to Chaparral Drive)*.

This street section consists of a 4-lane divided road with 2 travel lanes in each direction, as well as bike lanes and existing sidewalks on both sides. Sidewalks are separated from the street by a landscaped parkway on portions of the street north of Silverado Court. The median will also be landscaped.

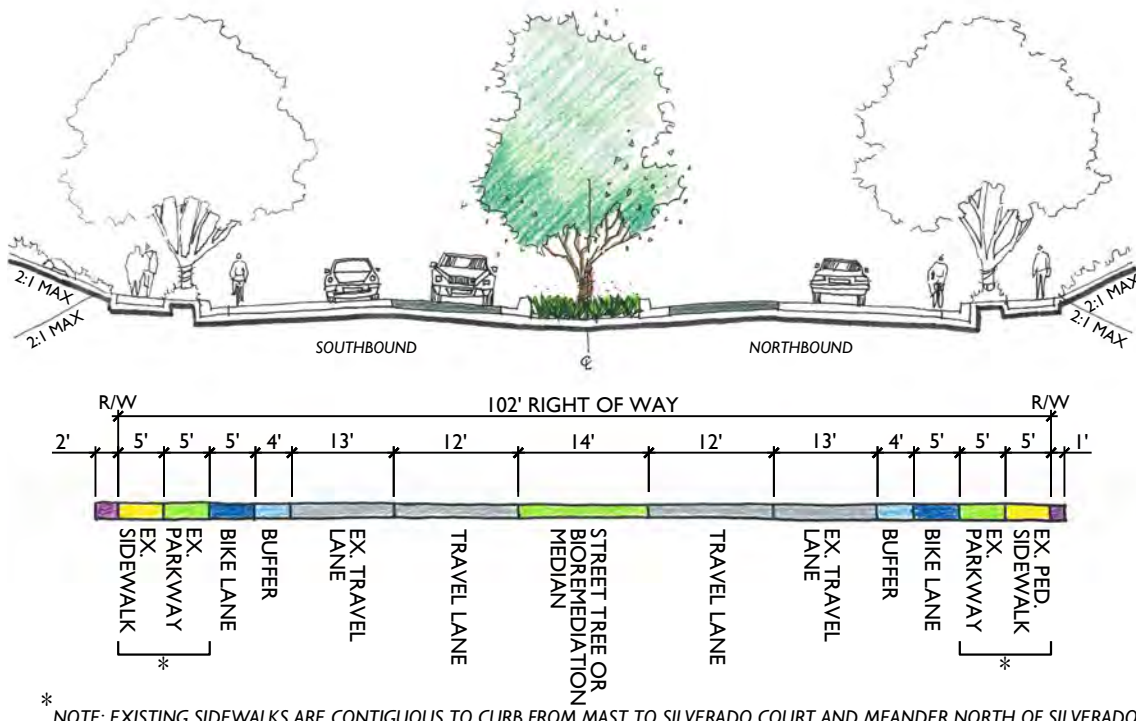


**Key Map**  
not to scale

Design Standards <sup>1</sup>	
Volume	15,000 - 40,000 Average Daily Trips
Design Speed	50 mph
Modes	<ul style="list-style-type: none"> <li>• Vehicles</li> <li>• Bicycles</li> <li>• Pedestrians</li> </ul>
Dimensions	
Right-of-Way Width	102 feet
Curb-to-Curb Width	34 feet in each direction
Median	14 feet wide, raised and landscaped
Landscape Scheme	
Style	Informal median planting
Tree Spacing	35 - 70 feet on center
Roadside FMZ	None

1. For full engineering street design criteria, refer to Table 4.1: Street Design Criteria. (Tentative Map Street Section No. 2)





## Landscape Palette:

### Trees

- QUERCUS ILEX - Holly Oak
- CHILOPSIS LINEARIS CULT. - Desert Willow Cultivars
- CERCIDIUM 'DESERT MUSEUM' - Palo Verde \*Photo: Star Nursery

### Shrubs / Perennials

- GREVILLEA SP. - Grevillea
- LAVANDULA DENTATA - French Lavender
- AGAVE ATTENUATA - Agave

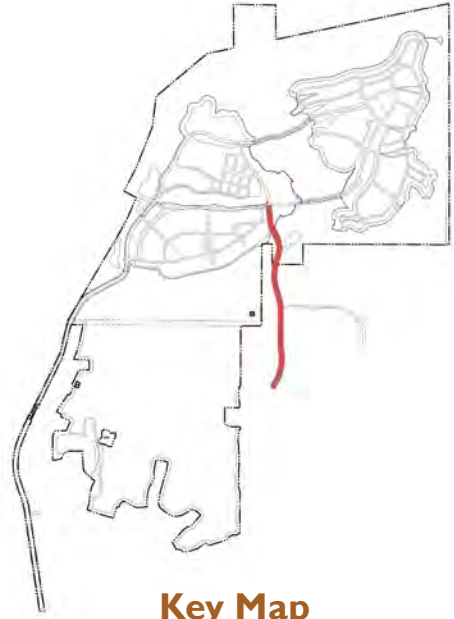
### Groundcovers

- LANTANA X 'NEW GOLD' - New Gold Lantana
- SENECIO SP. - Blue Chalksticks

## Exhibit 4.12.5: Cuyamaca Street, Off-Site - 4-Lane Major Arterial (Mast Boulevard to Chaparral Drive)

### 4.2.6 Cuyamaca Street, On & Off-Site - 2-Lane Parkway Type I (Chaparral Drive to Street “A”/Street “W”)

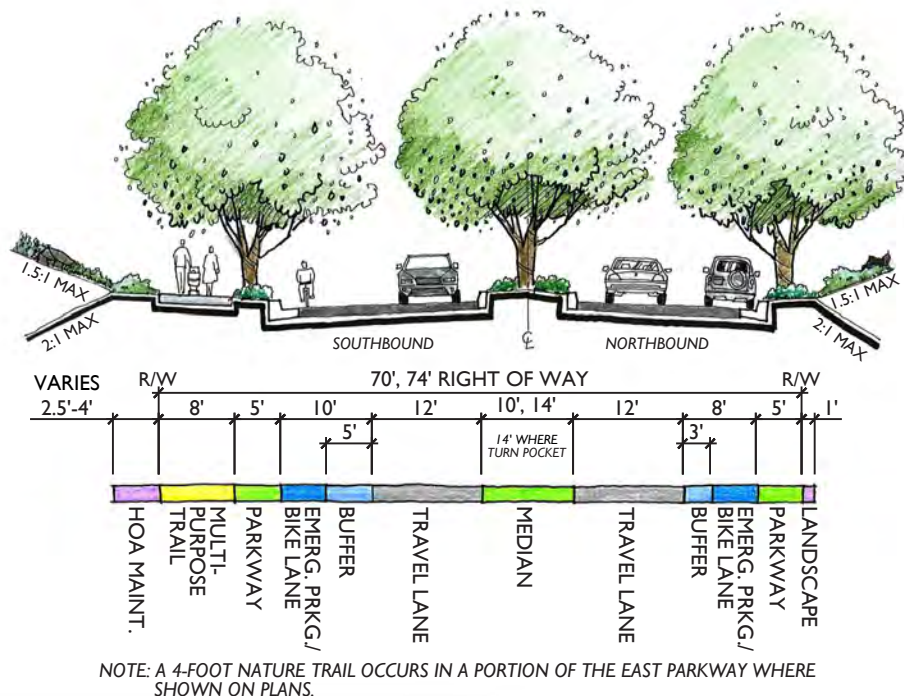
Cuyamaca Street will be extended beyond Chaparral Drive, as illustrated in *Exhibit 4.12.6: Cuyamaca Street, On & Off-Site - 2-Lane Parkway Type I (Chaparral Drive to Street “A”/Street “W”)*. This street section consists of a 2-lane divided road with bike lanes in each direction and an 8-foot multi-purpose trail on the west side of the street. A 4-foot wide nature trail on the east side of Cuyamaca Street will connect an existing primitive trail at the reservoir access road to the village nature trail at the first roundabout at Streets “A”/“W.” The width of this street section has been minimized and the alignment carefully planned to decrease grading while providing full mobility and emergency access. This section of roadway seeks to preserve the scenic character of the rock outcroppings and topography as a gateway experience as described in *Section 5.2.1: Cuyamaca Street Gateway*.



**Key Map**  
not to scale

Design Standards <sup>1</sup>	
Volume	5,000-15,000 Average Daily Trips
Design Speed	40 mph (20 mph in vicinity of roundabout)
Modes	<ul style="list-style-type: none"> <li>• Vehicles</li> <li>• Bicycles</li> <li>• Pedestrians</li> </ul>
Dimensions	
Right-of-Way Width	70 feet, 74 feet at turn pockets
Curb-to-Curb Width	<ul style="list-style-type: none"> <li>• West side (southbound): 22 feet</li> <li>• East side (northbound): 20 feet</li> </ul>
Median	10 feet wide (increases to 14 feet wide at turn pockets), raised and landscaped
Modes	
Landscape Scheme	
Style	Informal “Chaparral” parkway and median planting
Tree Spacing	75 - 500 feet on center
Roadside FMZ	50 feet both sides

1. For full engineering street design criteria, refer to *Table 4.1: Street Design Criteria*. (Tentative Map Street Section No. 3)



## Landscape Palette:

### Trees

- QUERCUS AGRIFOLIA - Coast Live Oak
- QUERCUS ILEX - Holly Oak
- CHILOPSIS LINEARIS CULT. - Desert Willow Cultivars

### Shrubs / Perennials

- RHAMNUS CALIFORNICA - California Coffeeberry
- AGAVE WEBERI - Weber's Agave
- OPUNTIA FICUS-INDICA - Prickly Pear or Nopales

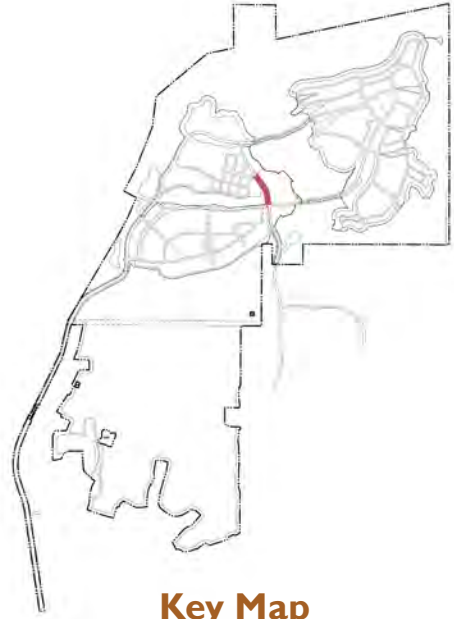
### Groundcovers

- BACCHARIS P. 'PILULARIS' - Dwarf Coyote Bush
- COTONEASTER DAMMERI 'LOWFAST' - Lowfast Bearberry Cotoneaster
- ACHILLEA 'MILLEFOLIUM' - Yarrow

## Exhibit 4.12.6: Cuyamaca Street, On & Off-Site - 2-Lane Parkway Type I (Chaparral Drive to Street "A"/Street "W")

### 4.2.7 Cuyamaca Street - Residential Collector Type V (Street “A”/Street “W” to Street “T”)

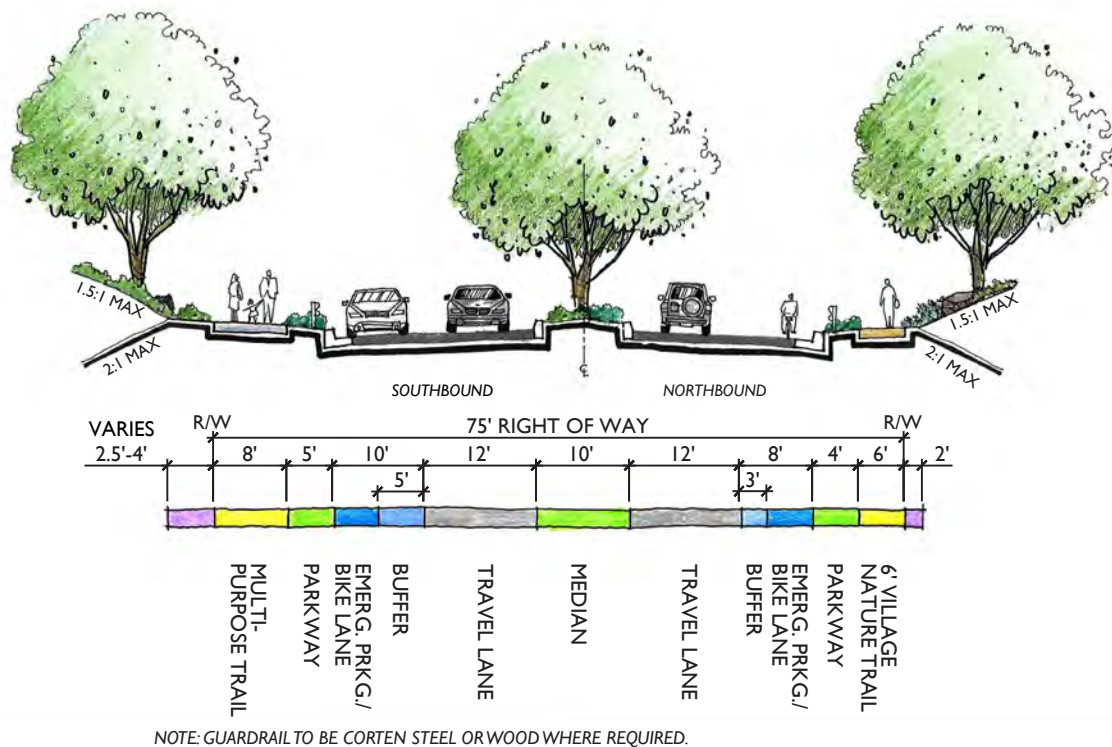
From Street “A”/Street “W” northward to Street “T” in Fanita Commons, Cuyamaca Street transitions to the cross section illustrated in *Exhibit 4.12.7: Cuyamaca Street - Residential Collector Type V (Street “A”/Street “W” to Street “T”)*. This street section consists of a 2-lane divided road with bike lanes in each direction, an 8-foot multi-purpose trail on the west side of the street and a 6-foot Village Nature Trail adjacent to the Farm on the east side of the street. This section of road slopes down toward the Fanita Commons Village Center, offering views of the Farm and hills north of the Village, reflecting the agrarian character of Fanita Ranch.



**Key Map**  
not to scale

Design Standards <sup>1</sup>	
Volume	4,000 - 10,000 Average Daily Trips
Design Speed	35 mph (20 mph in vicinity of roundabout)
Modes	<ul style="list-style-type: none"> <li>• Vehicles</li> <li>• Bicycles</li> <li>• Pedestrians</li> </ul>
Dimensions	
Right-of-Way Width	75 feet
Curb-to-Curb Width	<ul style="list-style-type: none"> <li>• West side (southbound): 22 feet</li> <li>• East side (northbound): 20 feet</li> </ul>
Median	10 feet wide, raised and landscaped
Landscape Scheme	
Style	Informal “Chaparral” parkway and median planting
Tree Spacing	75 - 500 feet on center
Roadside FMZ	50 feet west side

1. For full engineering street design criteria, refer to *Table 4.1: Street Design Criteria. (Tentative Map Street Section No. 10)*



## Landscape Palette:

### Trees

- QUERCUS AGRIFOLIA - Coast Live Oak
- QUERCUS ILEX - Holly Oak
- CHILOPSIS LINEARIS CULT. - Desert Willow Cultivars

### Shrubs / Perennials

- RHAMNUS CALIFORNICA - California Coffeeberry
- AGAVE WEBERI - Weber's Agave
- OPUNTIA FICUS-INDICA - Prickly Pear or Nopales

### Groundcovers

- BACCHARIS P. 'PIGEON POINT' - Dwarf Coyote Bush
- COTONEASTER DAMMERI 'LOWFAST' - Lowfast Bearberry Cotoneaster
- ACHILLEA 'MOONSHINE' - Moonshine Yarrow

## Exhibit 4.12.7: Cuyamaca Street - Residential Collector Type V (Street "A"/Street "W" to Street "T")



### 4.2.8 Cuyamaca Street - Village Collector (Street “T” to Fanita Parkway)

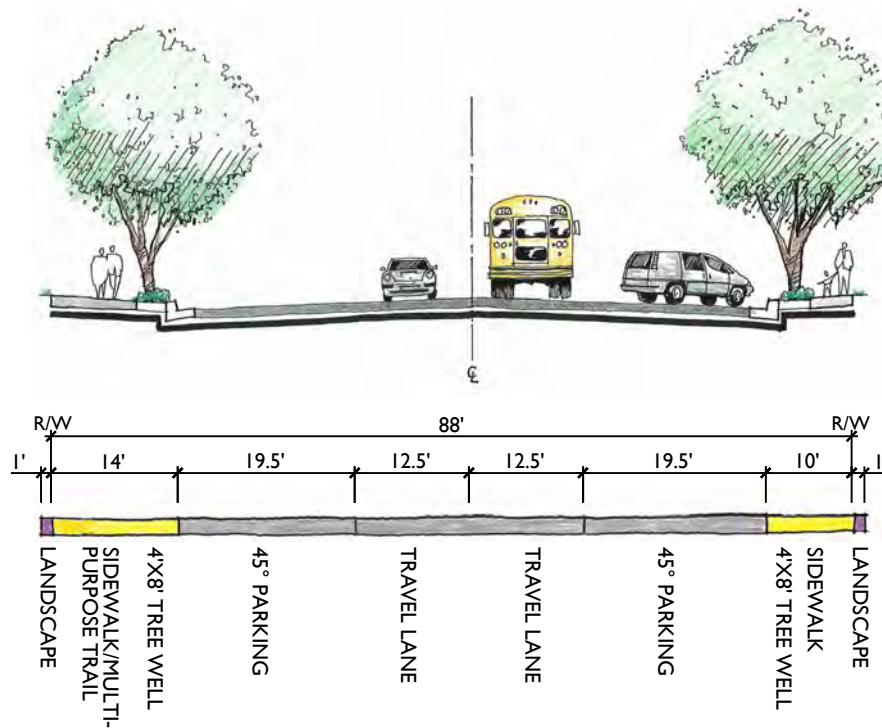
From Street “T” to Fanita Parkway, Cuyamaca Street transitions to the cross section illustrated in *Exhibit 4.12.8: Cuyamaca Street – Village Collector (Street “T” to Fanita Parkway)*. This street section consists of a 2-lane road with 45 degree angled parking in each direction, a 14-foot sidewalk/ multi-purpose trail on the west side of the street and a 10-foot sidewalk on the east side of the street. Landscape pockets are located intermittently between angled parking stalls.



**Key Map**  
not to scale

Design Standards <sup>1</sup>	
Volume	4,000 - 10,000 Average Daily Trips
Design Speed	35 mph (20 mph in vicinity of roundabout)
Modes	<ul style="list-style-type: none"> <li>• Vehicles</li> <li>• NEVs</li> <li>• Bicycles</li> <li>• Pedestrians</li> </ul>
Dimensions	
Right-of-Way Width	88 feet
Curb-to-Curb Width	64 feet
Median	None
Landscape Scheme	
Style	Formal parkway
Tree Spacing	30 - 50 feet on center
Roadside FMZ	None

1. For full engineering street design criteria, refer to *Table 4.1: Street Design Criteria*. (Tentative Map Street Section No. 11)



## Landscape Palette:

### Trees

- CERCIS C. 'FOREST PANSY' - Forest Pansy Redbut
- GEIJERA PARVIFLORA - Australian Willow
- KOELREUTERIA PANICULATA - Golden Rain Tree

### Shrubs / Perennials

- AGAVE 'BLUE GLOW' – Blue Glow Agave
- RHAPHIOLEPIS SP. – Indian Hawthorn

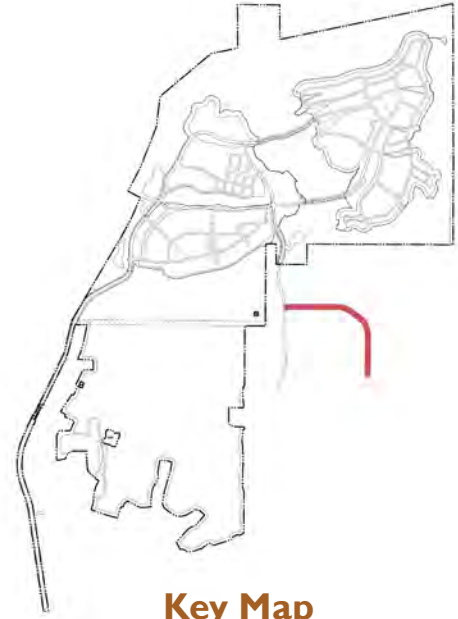
### Groundcovers

- CRASSULA MULTICAVA – Fairy Crassula
- FRAGARIA CHILOENSIS – Ornamental Strawberry
- MYOPORUM P. 'PINK' - Pink Myoporum

**Exhibit 4.12.8: Cuyamaca Street - Village Collector**  
(Street "T" to Fanita Parkway)

### 4.2.9 Magnolia Avenue, Off-Site - Collector Type IV (Existing Terminus to Cuyamaca Street)

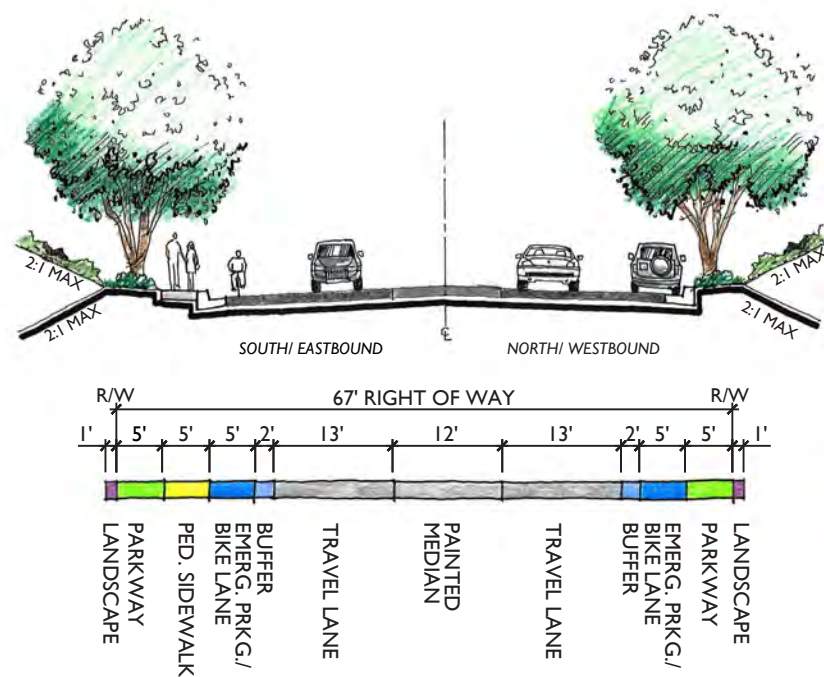
Magnolia Avenue will be extended from its current terminus and curve to the west to intersect with Cuyamaca Street outside the Specific Plan Area boundary. *Exhibit 4.12.9: Magnolia Avenue, Off-Site – Collector Type IV (Existing Terminus to Cuyamaca Street)* illustrates the proposed street section for this new segment of roadway, which provides additional access to Fanita Ranch via Cuyamaca Street. This street section consists of 2 travel lanes, a painted center median, bike lanes/emergency parking on both sides, a landscaped parkway on one side and a continuous sidewalk on the other side.



**Key Map**  
not to scale

Design Standards <sup>1</sup>	
Volume	4,000 - 10,000 Average Daily Trips
Design Speed	35 mph
Modes	<ul style="list-style-type: none"> <li>• Vehicles</li> <li>• Bicycles</li> <li>• Pedestrians</li> </ul>
Dimensions	
Right-of-Way Width	67 feet
Curb-to-Curb Width	52 feet
Median	12 feet wide, painted
Modes	
Landscape Scheme	
Style	Formal parkway planting
Tree Spacing	50 feet on center
Roadside FMZ	50 feet both sides

1. For full engineering street design criteria, refer to *Table 4.1: Street Design Criteria*. (Tentative Map Street Section No. 9)



## Landscape Palette:

### Trees

- MAGNOLIA GRANDIFLORA 'MAJESTIC BEAUTY' - Southern Magnolia
- LOPHOSTEMON CONFERTUS - Brisbane Box
- HYMENOSPORUM FLAVUM - Sweetshade

### Shrubs / Perennials

- CEANOTHUS SP. - California Lilac
- CISTUS SP. - Rockrose
- HEMEROCALLIS SP. - Daylily

### Groundcovers

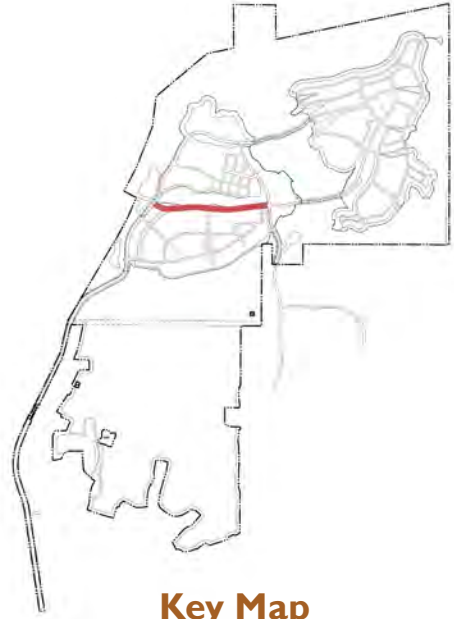
- BACCHARIS P. 'PIGEON POINT' - Dwarf Coyote Bush
- ERIGERON KARVINSKIANUS - Santa Barbara Daisy
- CISTUS SKANBERGII - Pink Rock Rose

## Exhibit 4.12.9: Magnolia Avenue, Off-Site - Collector Type IV (Existing Terminus to Cuyamaca Street)

### 4.2.10 Residential Collector Type I

#### (Fanita Parkway to Cuyamaca Street)

Exhibit 4.12.10: Residential Collector Type I (Fanita Parkway to Cuyamaca Street) illustrates the residential collector street located adjacent to the south drainage connecting Fanita Parkway and Cuyamaca Street. This roadway is adjacent to the southerly bank of the drainage and is elevated above Fanita Commons offering significant views of the main Village Center below. A neighborhood park and 6-foot trail along the drainage provide recreational opportunities, as well as a pedestrian connection via a pedestrian bridge to the school site and the Village Center.

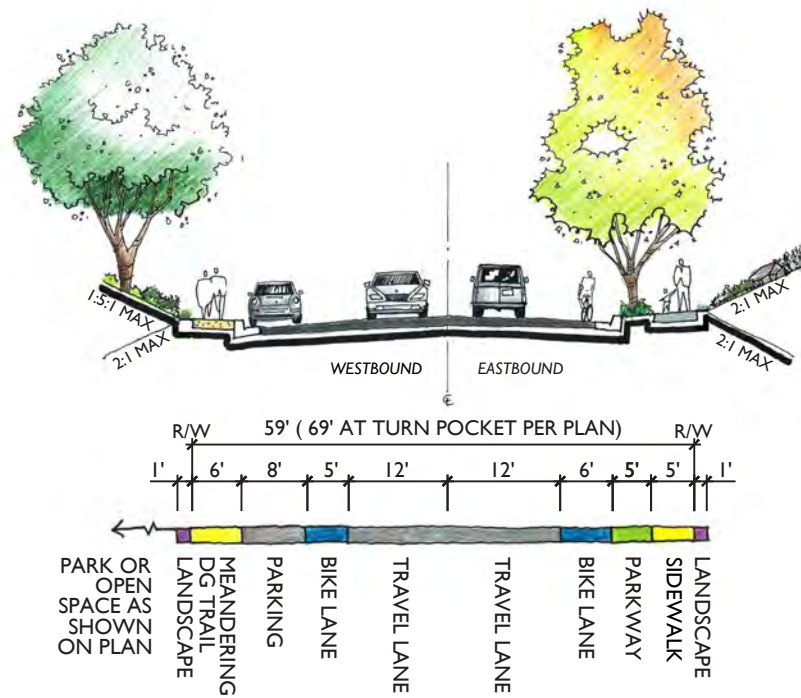


**Key Map**  
not to scale

Design Standards <sup>1</sup>	
Volume	4,000 - 10,000 Average Daily Trips
Design Speed	35 mph
Modes	<ul style="list-style-type: none"> <li>• Vehicles</li> <li>• NEVs</li> <li>• Bicycles</li> <li>• Pedestrians</li> </ul>
Dimensions	
Right-of-Way Width	59 feet, 69 feet at turn pockets
Curb-to-Curb Width	43 - 53 feet
Median	10 feet wide painted at left turn pockets
Landscape Scheme	
Style	Informal “Riparian” parkway planting
Tree Spacing	75 - 500 feet on center
Roadside FMZ	30 feet on north side

1. For full engineering street design criteria, refer to Table 4.1: Street Design Criteria. (Tentative Map Street Section No. 6)





## Landscape Palette:

### Trees

- QUERCUS AGRIFOLIA - Coast Live Oak
- CHILOPSIS LINEARIS CULT. - Desert Willow Cultivars
- QUERCUS ILEX - Holly Oak

### Shrubs / Perennials

- IVA HAYESIANA - San Diego Poverty Weed
- AGAVE PARRYI - Parry Agave
- FESTUCA MAIREI - Atlas Fescue

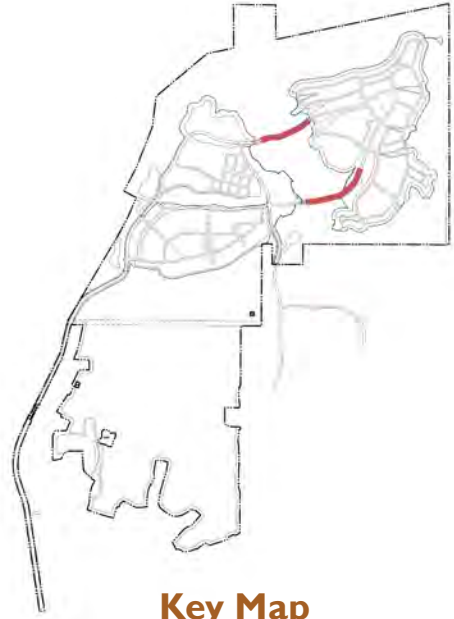
### Groundcovers

- MYOPROUM X 'PACIFICA' - Trailing Myoporum
- CEANOOTHUS G. HORIZONTALIS - Carmel Creeper
- CRASSULA MULTICAVA - Fairy Crassula

**Exhibit 4.12.10: Residential Collector Type I**  
(Fanita Parkway to Cuyamaca Street)

### 4.2.II Residential Collector Type II (Through Habitat Preserve - Streets “V” and “W”)

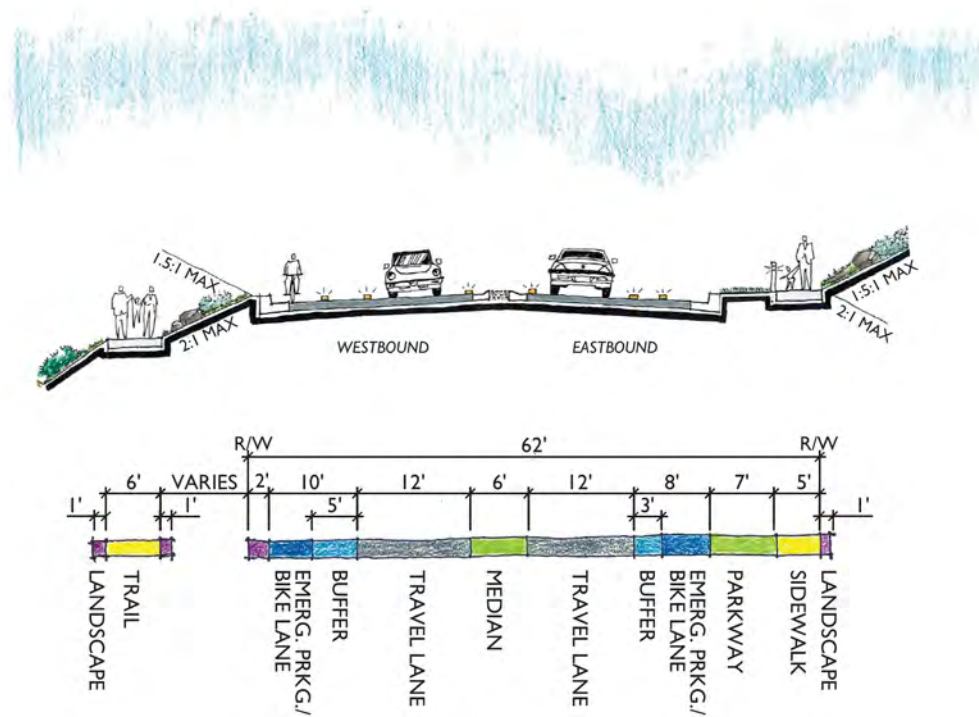
Where the Residential Collector Type II crosses the Habitat Preserve, a special street section has been designed to accommodate wildlife crossing and minimize disturbance of the Habitat Preserve. As illustrated in *Exhibit 4.12.11: Residential Collector Type II (Through Habitat Preserve - Streets “V” and “W”)*, the street section is narrow to minimize grading and the crossing distance for wildlife. The 6-foot median is specially designed to minimize barriers perceived by wildlife. Paving through this segment of roadway may consist of colored pavement that mimics the natural terrain. Because these street segments are major fire evacuation routes, landscaping will be permanently irrigated and limited to low growing, fire-resistive shrubs and ground covers with a few trees.



**Key Map**  
not to scale

Design Standards <sup>1</sup>	
Volume	4,000 - 10,000 Average Daily Trips
Design Speed	35 mph
Modes	<ul style="list-style-type: none"> <li>• Vehicles</li> <li>• NEVs</li> <li>• Bicycles</li> <li>• Pedestrians</li> </ul>
Dimensions	
Right-of-Way Width	62 feet
Curb-to-Curb Width	48 feet
Median	6-foot wide median with rolled curb, no landscaping
Landscape Scheme	
Style	Informal planting of fire-resistive ground covers, shrubs and a few trees
Paving	Special colored concrete to blend with natural surroundings
Roadside FMZ	50 feet on both sides

1. For full engineering street design criteria, refer to *Table 4.1: Street Design Criteria*. (Tentative Map Street Section No. 7)  
 2. See *Section 5.9: Conceptual Lighting Plan* for lighting details.



## Landscape Palette:

### Trees

- QUERCUS AGRIFOLIA - Coast Live Oak
- QUERCUS ILEX - Holly Oak
- CHILOPSIS LINEARIS CULT. - Desert Willow Cultivars

### Shrubs / Perennials

- GALVEZIA SPECIOSA - Island Bush Snapdragon
- IVA HAYESIANA - Hayes Ivy
- RHAMNUS CROCEA - Red Coffeeberry

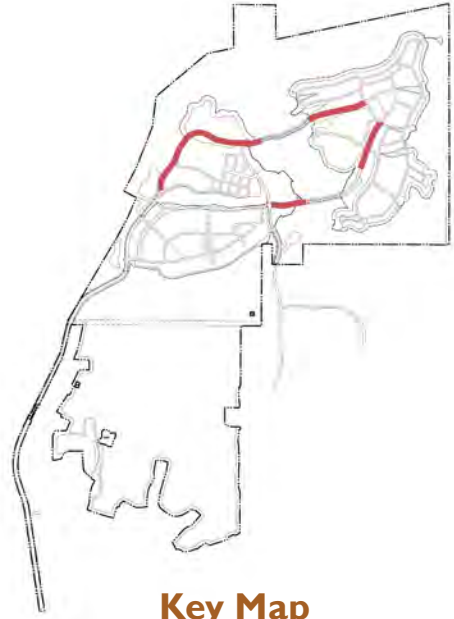
### Groundcovers

- BACCHARIS P. 'PILULARIS' - Dwarf Coyote Bush
- CISTUS SP. - Rockrose
- MYOPORUM P. 'PINK' - Pink Myoporum

## Exhibit 4.12.11: Residential Collector Type II (Through Habitat Preserve - Streets "V" and "W")

### 4.2.12 Residential Collector Type III

The Residential Collector Type III street section applies to a variety of internal roadway segments, including portions of Fanita Parkway and Street “A” that traverse various Villages. The section, as illustrated *Exhibit 4.12.12: Residential Collector Type III*, consists of a 2-lane divided road with bike lanes on both sides and a 14-foot raised and landscaped median. In some locations, the section provides 5-foot sidewalks on both sides. In other locations, the sidewalk on one side of the street is replaced by a 6-foot or 10-foot trail to provide continuous trail connectivity, based upon location within the community. Landscape palette and style vary by Village.

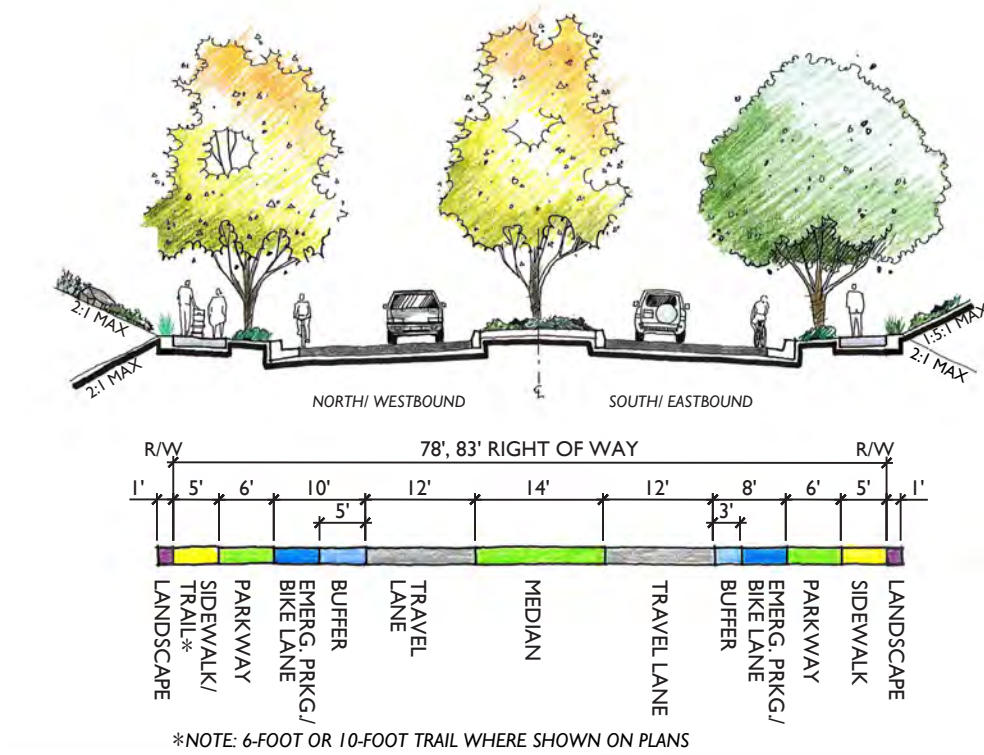


**Key Map**  
not to scale

Design Standards <sup>1</sup>	
Volume	4,000 - 10,000 Average Daily Trips
Design Speed	35 mph
Modes	<ul style="list-style-type: none"> <li>• Vehicles</li> <li>• NEVs</li> <li>• Bicycles</li> <li>• Pedestrians</li> </ul>
Dimensions	
Right-of-Way Width	78 feet, 83 feet
Curb-to-Curb Width	22 feet on the west/north side, 20 feet on the east/south side
Median	14 feet wide, raised and landscaped
Landscape Scheme	
Style	Informal “Chaparral” or “Riparian” parkway planting by Village
Tree Spacing	75 - 500 feet on center
Roadside FMZ	No FMZ, or 30 feet or 50 feet per Tentative Map; varies

1. For full engineering street design criteria, refer to *Table 4.1: Street Design Criteria*. (Tentative Map Street Section No. 8)





Refer to *Chapter 5: Landscape Architecture, Community Design & Outdoor Lighting Design Plan* for specific plant palettes by Village.



**Exhibit 4.12.12: Residential Collector Type III**



### 4.2.13 Residential Collector Type VII

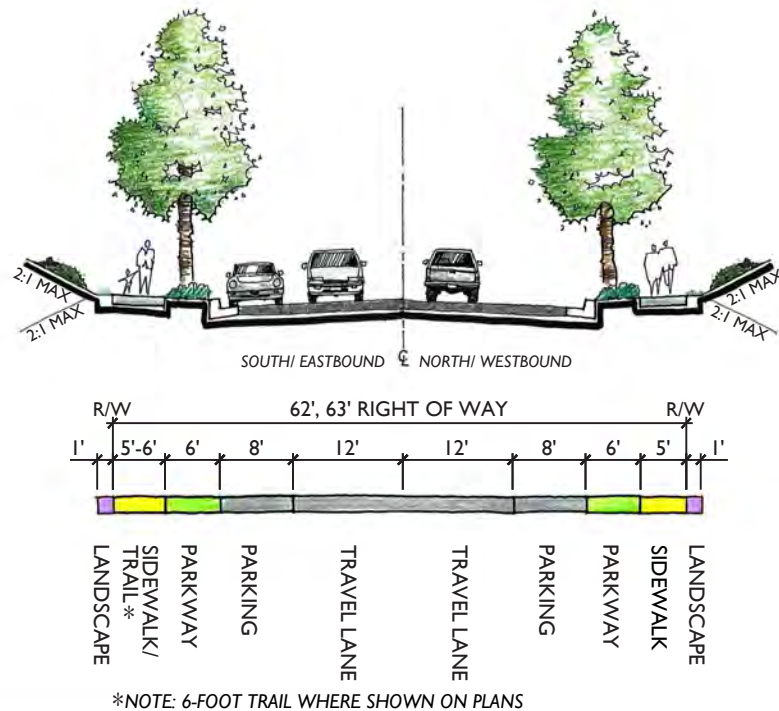
This Residential Collector Type VII section, as illustrated in *Exhibit 4.12.13: Residential Collector Type VII*, occurs in Orchard and Vineyard Villages. This street section consists of a 2-lane road with parking, parkways and sidewalks on both sides.



**Key Map**  
not to scale

Design Standards <sup>1</sup>	
Volume	4,000 - 10,000 Average Daily Trips
Design Speed	25 mph
Modes	<ul style="list-style-type: none"> <li>• Vehicles</li> <li>• NEVs</li> <li>• Bicycles</li> <li>• Pedestrians</li> </ul>
Dimensions	
Right-of-Way Width	62 feet (63 feet with 6-foot trail option)
Curb-to-Curb Width	40 feet
Median	None
Landscape Scheme	
Style	Formal parkway and median planting
Tree Spacing	50 feet on center
Roadside FMZ	None

1. For full engineering street design criteria, refer to *Table 4.1: Street Design Criteria*. (Tentative Map Street Section No. 12)



## Landscape Palette:

### Trees

- LOPHOSTEMON CONFERTUS - Brisbane Box
- Liquidambar styraciflua - Sweetgum
- MAGNOLIA GRANDIFLORA 'MAJESTIC BEAUTY' - Southern Magnolia

### Shrubs / Perennials

- DIETES SP. - Fortnight Lily
- ESCALLONIA 'NEWPORT DWARF' - Escallonia 'Newport Dwarf'
- PITTOSPORUM T. 'WHEELER'S DWARF' - Dwarf Mock Orange

### Groundcovers

- AECHILLEA 'MOONSHINE' - Moonshine Yarrow
- FESTUCA MAIREI - Atlas Fescue
- HEMEROCALLIS SP. - Daylily

## Exhibit 4.12.13: Residential Collector Type VII

### 4.2.14 Residential Street

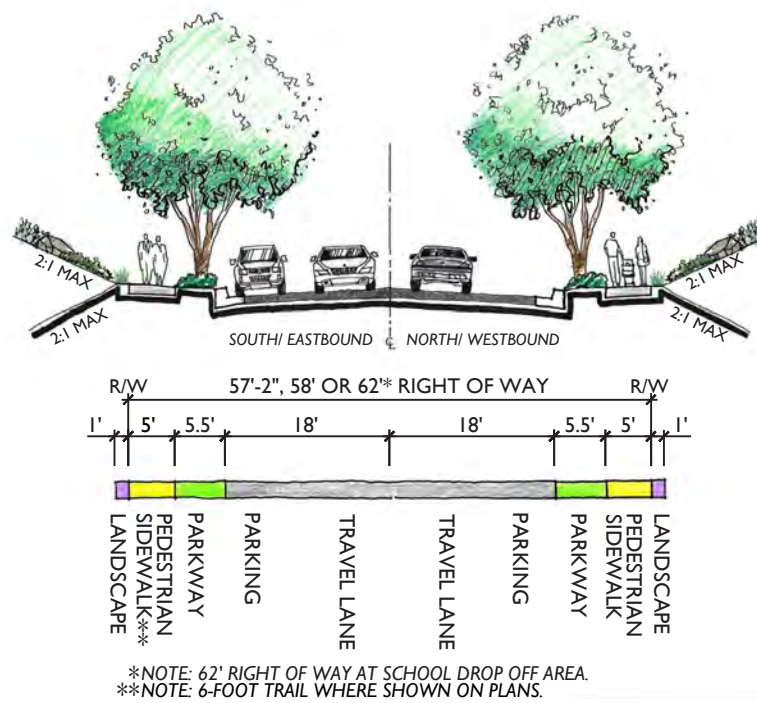
Residential streets include conventional 2-way streets with parallel parking on both sides, as illustrated in *Exhibit 4.12.14: Residential Street*. Street trees provide shade for pavement and parked cars to reduce heat island effect. Sidewalks are provided on both sides. In select locations the sidewalk on one side is replaced with a 6-foot trail. Plant palette varies by Village. This street is modified along the school site to accommodate pedestrian circulation and drop-off. The final design will be coordinated with the Santee School District during school site design.



**Key Map**  
not to scale

Design Standards <sup>1</sup>	
Volume	2,200 Average Daily Trips
Design Speed	25 mph
Modes	<ul style="list-style-type: none"> <li>• Vehicles</li> <li>• NEVs</li> <li>• Bicycles</li> <li>• Pedestrians</li> </ul>
Dimensions	
Right-of-Way Width	57 feet (58 feet with 6-foot trail option; 62 feet at school drop-off)
Curb-to-Curb Width	36 feet (41 feet at school drop-off)
Median	None
Landscape Scheme	
Style	Formal parkway planting
Tree Spacing	50 feet on center
Roadside FMZ	50 feet on south side of Street “N” only per Tentative Map

1. For full engineering street design criteria, refer to *Table 4.1: Street Design Criteria*. (Tentative Map Street Section No. 16)



Refer to *Chapter 5: Landscape Architecture, Community Design & Outdoor Lighting Design Plan* for specific plant palettes by Village.



**Exhibit 4.12.14: Residential Street**

### 4.2.15 Carlton Hills Boulevard (Private Street)

Carlton Hills Boulevard is an existing dead-end street that provides access to the Special Use Area, a Padre Dam Municipal Water District reservoir and a mini park that includes a trail staging area. The existing asphalt curbs will be replaced with concrete curb and gutter and a sidewalk will be added to the west side of the street (see *Exhibit 4.12.15: Carlton Hills Boulevard - Private Street*). Due to existing geologic conditions, permanent irrigation is not allowed. Plantings will be limited to a non-irrigated hydroseed mix of hardy native grasses, forbs, perennials and a few shrubs as required for implementation of BMPs within the 4' x 8' areas. The hydroseed mix will be applied in the winter to maximize establishment. This portion of Carlton Hills Boulevard may be designed as a public street during final engineering.

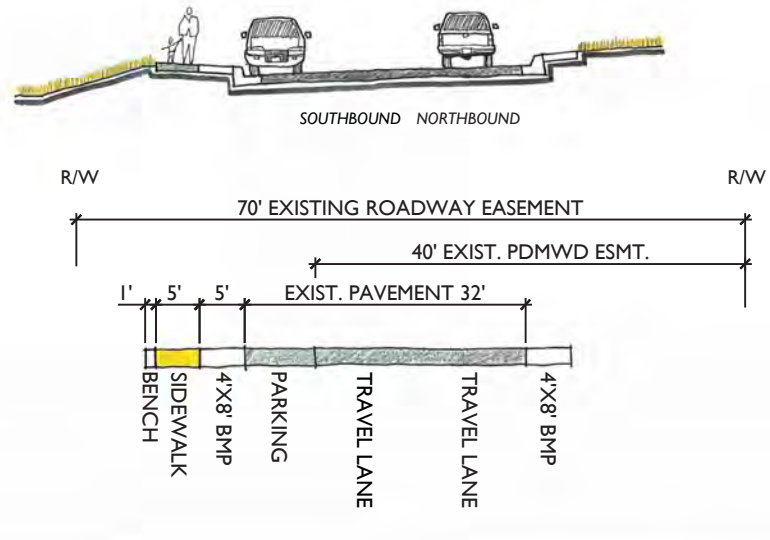


**Key Map**  
not to scale

Design Standards <sup>1</sup>	
Volume	2,200 Average Daily Trips
Design Speed	25 mph
Modes	<ul style="list-style-type: none"> <li>• Vehicles</li> <li>• Bicycles</li> <li>• Pedestrians</li> </ul>
Dimensions	
Right-of-Way Width	70 feet (existing roadway easement)
Curb-to-Curb Width	32 feet
Median	None
Landscape Scheme	
Style	Informal “Chaparral” planting
Tree Spacing	Not applicable
Roadside FMZ	None

1. For full engineering street design criteria, refer to *Table 4.1: Street Design Criteria*. (Tentative Map Street Section No. 18)



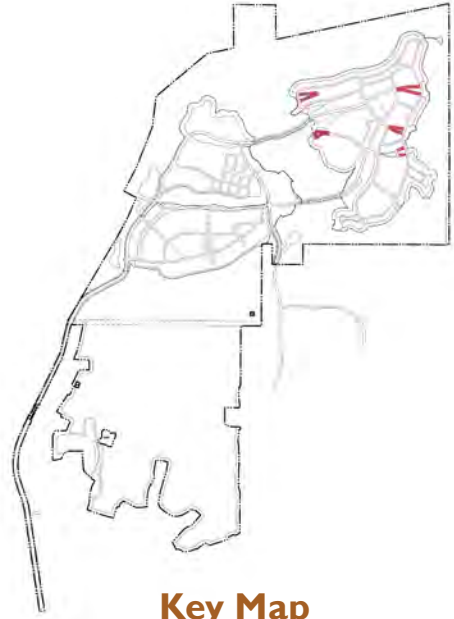


Plantings will be limited to a non-irrigated hydroseed mix of hardy native grasses, forbs, perennials and a few shrubs as required for implementation of BMPs within the 4' x 8' areas.

**Exhibit 4.12.15: Carlton Hills Boulevard - Private Street**

### 4.2.16 Split Residential Street (One-Way)

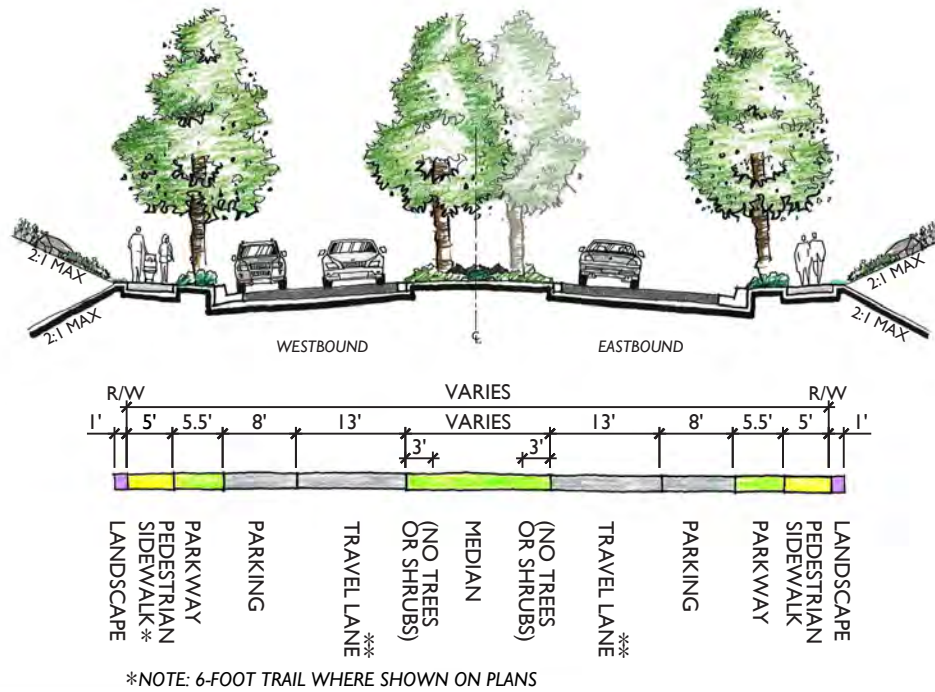
Split residential streets are one-way streets that are separated by a median or park. The width of the median or park varies as illustrated in *Exhibit 4.12.16: Split Residential Street (One-Way)*. These unique streets establish neighborhood character. Parallel parking and sidewalks are provided on both sides. In select locations, the sidewalk on one side is replaced with a 6-foot trail. Plant palette varies by Village.



**Key Map**  
not to scale

Design Standards <sup>1</sup>	
Volume	2,200 Average Daily Trips
Design Speed	25 mph
Modes	<ul style="list-style-type: none"> <li>• Vehicles</li> <li>• NEVs</li> <li>• Bicycles</li> <li>• Pedestrians</li> </ul>
Dimensions	
Right-of-Way Width	Varies
Curb-to-Curb Width	21 feet in each direction
Median	Varies
Landscape Scheme	
Style	Formal parkway planting
Tree Spacing	50 feet on center
Roadside FMZ	None

1. For full engineering street design criteria, refer to *Table 4.1: Street Design Criteria*. (Tentative Map Street Section No. 17)



Refer to *Chapter 5: Landscape Architecture, Community Design & Outdoor Lighting Design Plan* for specific plant palettes by Village.



**Exhibit 4.12.16: Split Residential Street (One-Way)**

### 4.2.17 Private Residential Street

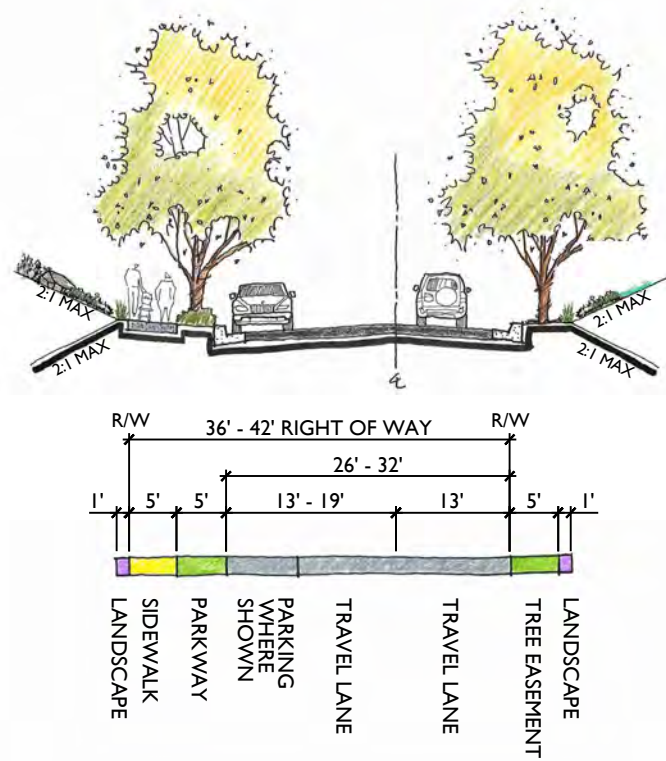
Private residential streets are local 2-way streets with parallel parking on one side and a street tree easement on the other side, as shown in *Exhibit 4.12.17: Private Residential Street*. These streets provide local access within a neighborhood creating an enclave-type feel. Street trees provide shade for pavement and parked cars to reduce heat island effect and for the comfort of pedestrians. A sidewalk is provided on one side of the street.



**Key Map**  
not to scale

Design Standards <sup>1</sup>	
Volume	1,100 Average Daily Trips
Design Speed	25 mph
Modes	<ul style="list-style-type: none"> <li>• Vehicles</li> <li>• Bicycles</li> <li>• Pedestrians</li> </ul>
Dimensions	
Right-of-Way Width	36 - 42 feet
Curb-to-Curb Width	26 - 32 feet
Median	None
Landscape Scheme	
Style	Formal parkway planting
Tree Spacing	50 feet on center
Roadside FMZ	None

1. For full engineering street design criteria, refer to *Table 4.1: Street Design Criteria*. (Tentative Map Street Section No. 19)



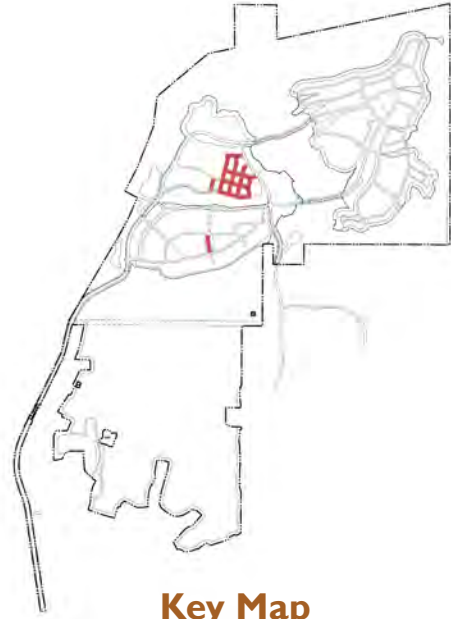
Refer to *Chapter 5: Landscape Architecture, Community Design & Outdoor Lighting Design Plan* for specific plant palettes by Village.

**Exhibit 4.12.17: Private Residential Street**



### 4.2.18 Village Streets

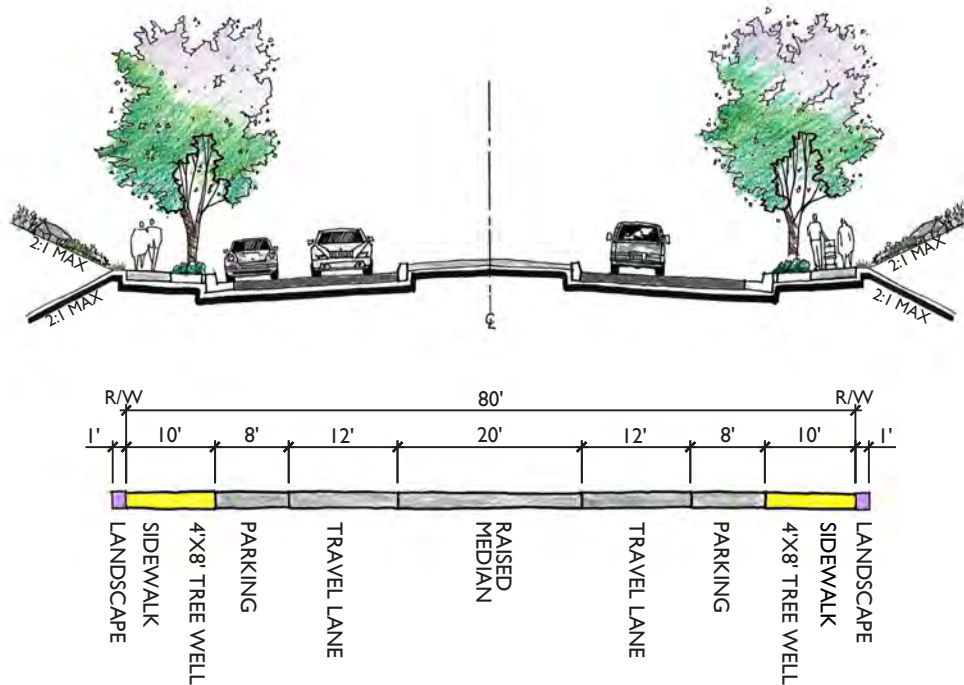
Within each Village Center, a variety of street sections are possible. This variety is intended to provide options in creating diversity in streetscapes that are consistent with the vision for walkable, “main street” style Village Centers. Each Village Street is designed to provide on-street parking in parallel or angled parking configurations. Each Village Street also includes a 10-foot sidewalk on each side, with tree wells located within the sidewalk approximately every 50 feet on center. Trees provide shade for pavement and parked cars to reduce heat island effect. Refer to *Exhibits 4.12.18 through 4.12.20*.



**Key Map**  
not to scale

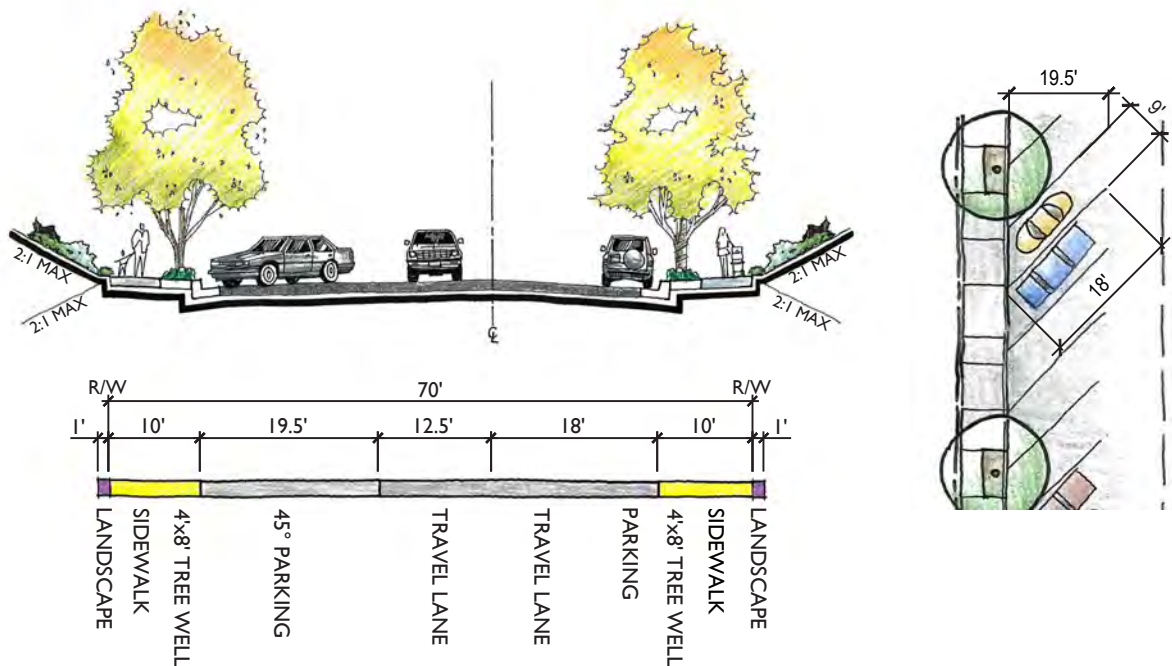
Design Standards <sup>1</sup>	
Volume	2,200 Average Daily Trips
Design Speed	25 mph
Modes	<ul style="list-style-type: none"> <li>• Vehicles</li> <li>• NEVs</li> <li>• Bicycles</li> <li>• Pedestrians</li> </ul>
Dimensions	
Right-of-Way Width	56 - 80 feet (depending upon section)
Curb-to-Curb Width	36 - 60 feet (depending upon section)
Median	Depends on section
Landscape Scheme	
Style	Formal parkway
Tree Spacing	50 feet on center
Roadside FMZ	30 feet for a portion of Street P per Tentative Map

1. For full engineering street design criteria, refer to *Table 4.1: Street Design Criteria*. (Tentative Map Street Sections No. 13, 14 and 15)



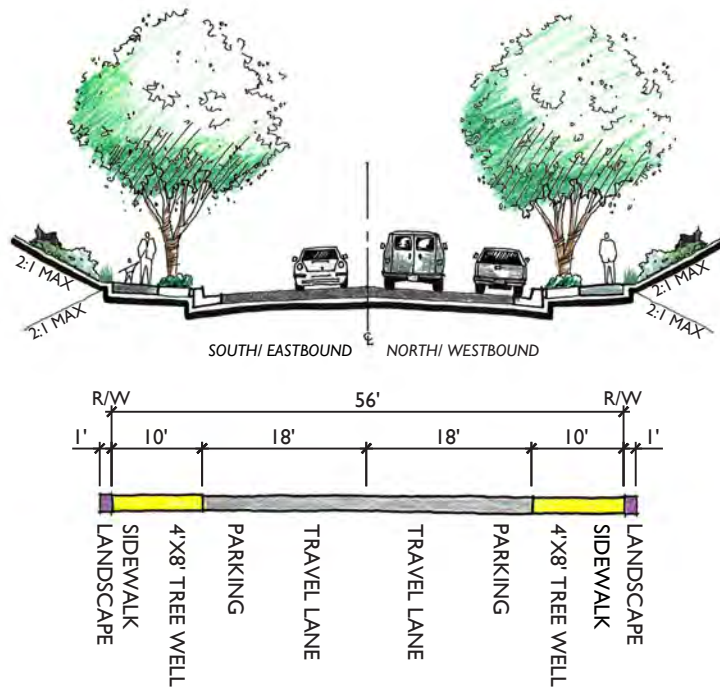
Refer to *Chapter 5: Landscape Architecture, Community Design & Outdoor Lighting Design Plan* for specific plant palettes by Village. (Tentative Map Street Section No. 13)

**Exhibit 4.12.18: Village Street Type I**



Refer to *Chapter 5: Landscape Architecture, Community Design & Outdoor Lighting Design Plan* for specific plant palettes by Village. (Tentative Map Street Section No. 14)

**Exhibit 4.12.19: Village Street Type II**



Refer to *Chapter 5: Landscape Architecture, Community Design & Outdoor Lighting Design Plan* for specific plant palettes by Village. (Tentative Map Street Section No. 15)

**Exhibit 4.12.20: Village Street Type III**

### 4.2.19 Private Residential Driveway

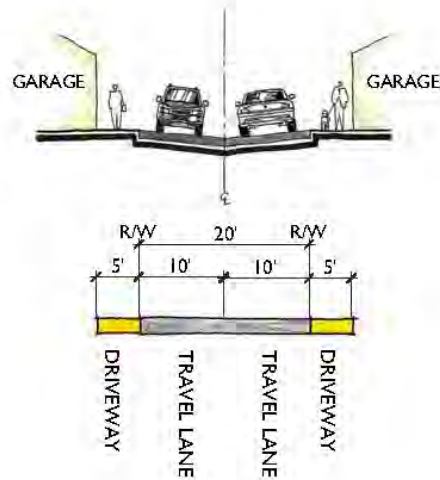
Private residential driveways provide access to garages located at the back of the buildings and are used to eliminate garage doors from the street to improve the street scene. Private residential driveways are located in Planning Area M-9 shown in *Exhibit 3.2: Site Utilization Plan* in Orchard Village and are also anticipated in residential areas within the Village Centers. As shown in *Exhibit 4.12.21: Private Residential Driveway*, these narrow travelways are intended for vehicle use and are designed for local access only. Because private residential driveways provide primary vehicular access to rear-loaded garages, they should be treated with landscaping, architectural articulation and lighting to create a pleasant and safe driving experience for the residents. To allow for landscaping, buildings shall be set back a minimum of 4 feet from the edge of the private residential driveway. Garage setbacks from the adjacent private residential driveway shall be 5 feet where no full garage driveway is provided for individual units or a minimum of 18 feet where full garage driveways are provided. Parking is prohibited along the private residential driveways.



**Key Map**  
not to scale

Design Standards <sup>1</sup>	
Volume	Less than 1,000 Average Daily Trips
Design Speed	15 mph
Modes	Vehicles
Dimensions	
Right-of-Way Width	20 feet
Curb-to-Curb Width	10 feet in each direction
Median	None
Landscape Scheme	
Style	Small trees, vines and shrubs
Tree Spacing	Not applicable
Roadside FMZ	None

1. For full engineering street design criteria, refer to *Table 4.1: Street Design Criteria. (Tentative Map Street Section No. 20)*



Refer to *Chapter 5: Landscape Architecture, Community Design & Outdoor Lighting Design Plan* for specific plant palettes by Village.



**Exhibit 4.12.21: Private Residential Driveway**



### 4.3 Trail Corridor & Landscape Standards

Thoughtful planning and design of trails is essential to encouraging their use for both transportation and recreation. In conformance with the Santee General Plan Trails Element, Fanita Ranch includes plans for more than 35 miles of trails. Trails are planned to provide safe, multi-modal paths that allow access for pedestrians and bicyclists throughout the community and to regional trails. An existing equestrian trail in the northeast corner of the Specific Plan Area will be maintained to connect Sycamore Canyon County Preserve to the north with the Oak Creek Drive area (in the County of San Diego) to the east. To ensure the long-term quality and viability of the trail system, trail maintenance will be provided by the entity that is responsible for the areas in which the trails are located, as shown in *Exhibit 10.2: Operation & Maintenance Responsibility Areas*.

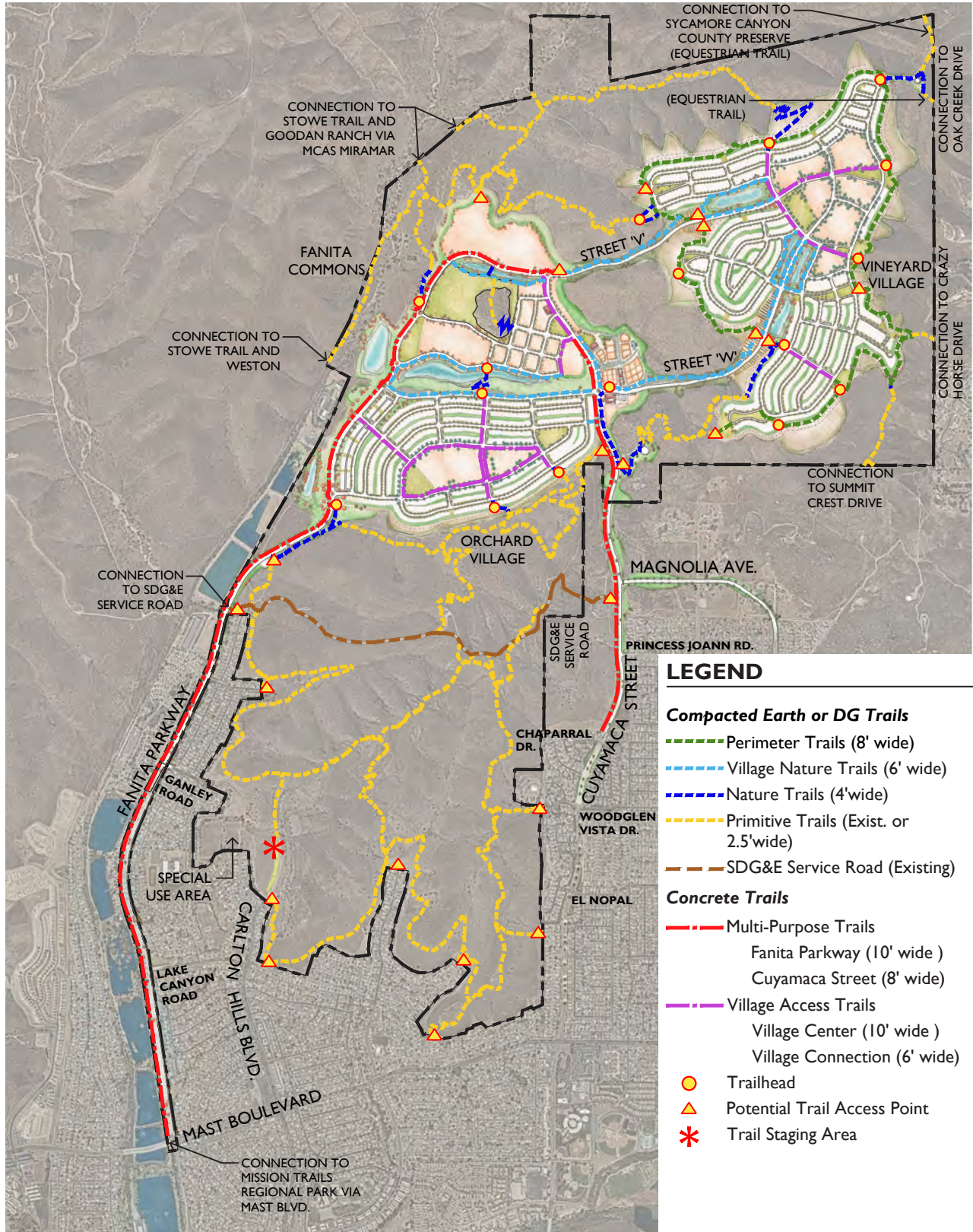
Trail surface type, width, grades, and vertical and horizontal clearances from vegetation and fixed objects will be designed in accordance with recognized standards as depicted in *Table 4.3: Trail Design*. Site amenities, such as trail maps, seating, shade and drinking fountains, will be sited at appropriate locations. Amenities in the Habitat Preserve shall be provided in accordance with the Public Access Plan (Fanita Ranch EIR Appendix D, Biological Resources Technical Report, Appendix T) requirements. Cable and post or post and rail fencing will be used where appropriate for user safety and the protection of surrounding habitat. Landscaping styles will be determined by adjacent landscapes such as the Habitat Preserve, riparian corridors or village themes, and will conform to the approved Fire Protection Plan and preserve management and restoration plans. *Exhibit 4.13: Trails Map* depict the Fanita Ranch trail system and *Exhibits 4.14.1 through 4.14.7* depict the standard trail sections.

**Table 4.3: Trail Design**

Trails Design Matrix					
Trail Type	Width	Surface	Grade <sup>1</sup>	Vertical Clearance	Horizontal Clearance
Multi-Purpose	10' - Fanita Parkway 8' - Cuyamaca Street	Concrete	≤12%	10'	2'
Village Access	10' Village Centers 6' to Village Center	Concrete	≤12%	10'	2'
Perimeter	8'	Earth or DG	≤15%	10'	2'
Village Nature	6'	Earth or DG	≤15%	10'	1'
Nature	4'	Earth or DG	≤20%	10'	1'
Primitive - Existing	Existing	Native Earth	Existing	10'	To Edge
Primitive - New <sup>2</sup>	2.5'	Native Earth	≤20%	10'	To Edge
SDG&E Service Road	Existing	Native Earth	Existing	Per SDG&E	To Edge

Notes:

1. These are optimum grade ranges. Actual grades will vary due to topography, existing conditions and environmental constraints.

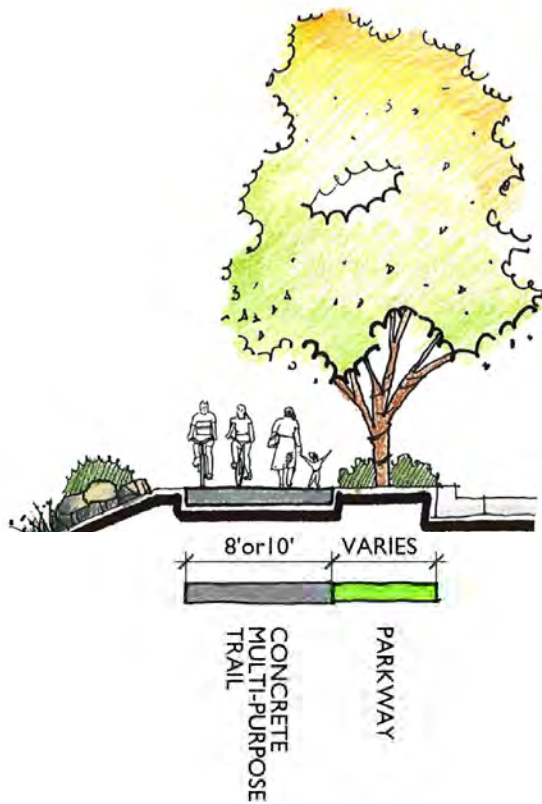


For illustrative purposes only; final design may vary.

**Exhibit 4.13: Trails Map**

⊕ not to scale





Multi-Purpose Trails are broad, all-weather, high user volume, concrete paved paths along Fanita Parkway and Cuyamaca Street that connect Fanita Ranch to Santee Lakes and greater Santee. Multi-Purpose Trails are separated from the roadways with a landscaped parkway strip that varies in width.

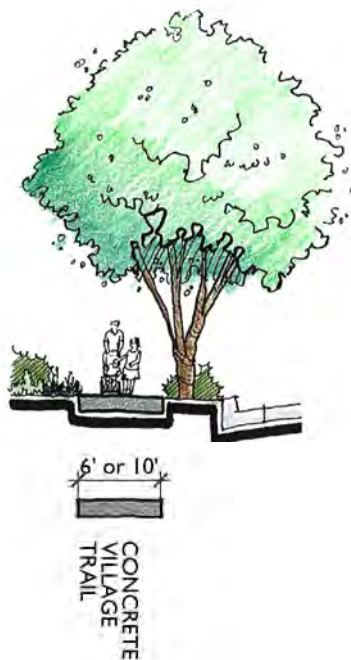
**Design Standards**

Width	10 feet - Fanita Parkway 8 feet - Cuyamaca Street
Surface	Concrete
Modes	<ul style="list-style-type: none"> <li>• Bicycles</li> <li>• Pedestrians</li> </ul>

Refer to *Chapter 5: Landscape Architecture, Community Design & Outdoor Lighting Design Plan* for specific plant palettes by Village.

**Exhibit 4.14.1: Multi-Purpose Trail**

Village Access Trails are broad, all-weather, high user volume, concrete paved paths that connect Village Centers to the community-wide trail system.

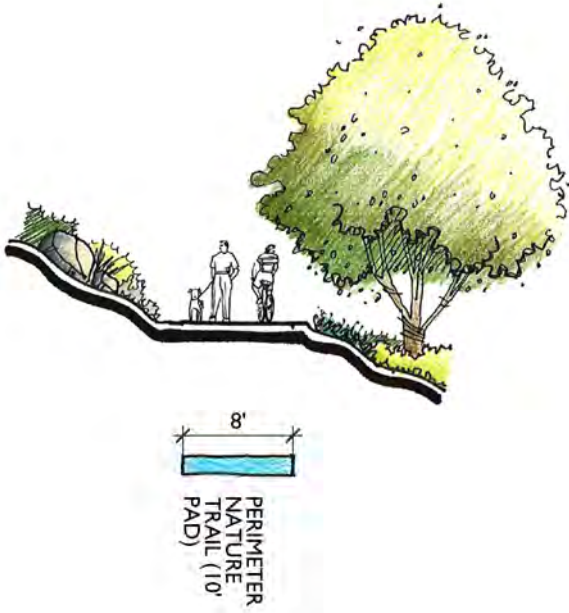


**Design Standards**

Width	10 feet wide and adjacent to curbs in Village Centers 6 feet elsewhere
Surface	Concrete
Modes	<ul style="list-style-type: none"> <li>• Bicycles</li> <li>• Pedestrians</li> </ul>

Refer to *Chapter 5: Landscape Architecture, Community Design & Outdoor Lighting Design Plan* for specific plant palettes by Village.

**Exhibit 4.14.2: Village Access Trail**



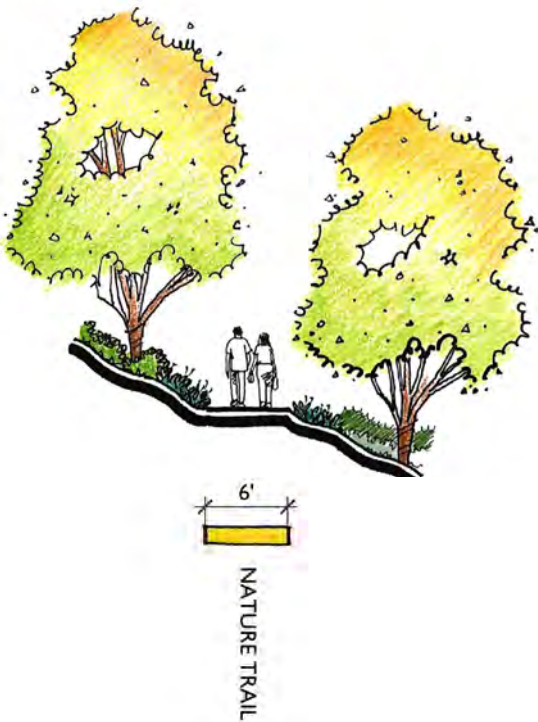
Perimeter Trails are 8-foot wide native earth or DG paths that loop around the Vineyard Village and are intended for recreational use and fire access. These trails also serve as maintenance access to the fuel modification zones. Neighborhood parks and mini-parks provide trail and maintenance access points.

**Design Standards**

Width	8 feet (10-foot bench)
Surface	Native Earth or DG
Modes	<ul style="list-style-type: none"> <li>• Bicycles</li> <li>• Pedestrians</li> </ul>

Refer to *Chapter 5: Landscape Architecture, Community Design & Outdoor Lighting Design Plan* for specific plant palettes by Village.

**Exhibit 4.14.3: Perimeter Trail**



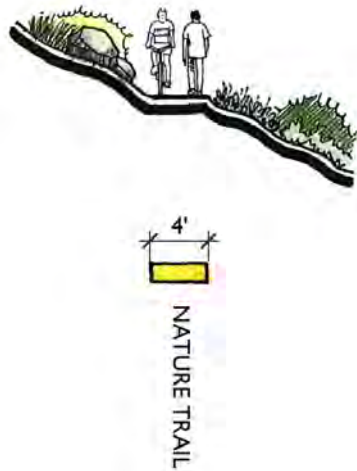
Village Nature Trails are 6-foot wide native earth or DG paths for maintenance vehicles and recreation uses. These trails connect Vineyard Village to Fanita Commons and the Farm through the Habitat Preserve, and provide access to the riparian areas and basins from Fanita Commons and Orchard and Vineyard Villages.

**Design Standards**

Width	6 feet
Surface	Native Earth or DG
Modes	<ul style="list-style-type: none"> <li>• Bicycles</li> <li>• Pedestrians</li> </ul>

Refer to *Chapter 5: Landscape Architecture, Community Design & Outdoor Lighting Design Plan* for specific plant palettes by Village.

**Exhibit 4.14.4: Village Nature Trail**



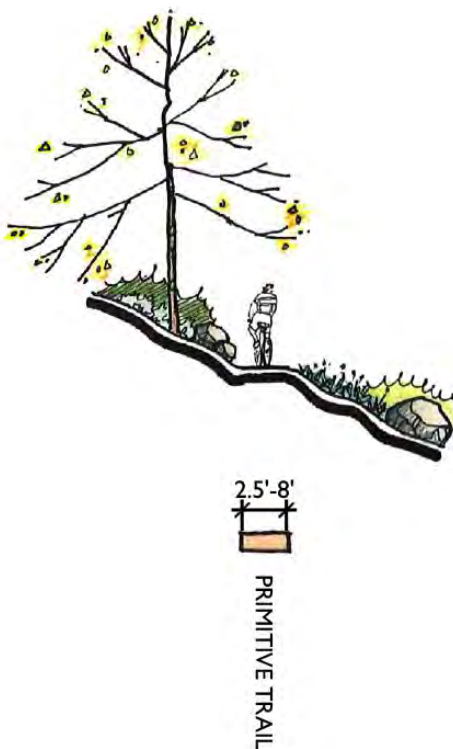
Nature Trails are 4-foot wide native earth or DG recreational trails that provide access from the developed area to the existing Primitive Trails in the Habitat Preserve. The final design of any Nature Trails in the Habitat Preserve shall be in accordance with MSCP Subarea Plan design standards.

**Design Standards**

Width	4 feet
Surface	Native Earth or DG
Modes	<ul style="list-style-type: none"> <li>• Bicycles</li> <li>• Pedestrians</li> </ul>

Refer to *Chapter 5: Landscape Architecture, Community Design & Outdoor Lighting Design Plan* for specific plant palettes by Village.

**Exhibit 4.14.5: Nature Trail**



Primitive Trails are existing and new native earth recreational trails of varying widths located in the Habitat Preserve. Where existing trails have been identified as negatively impacting sensitive habitat, the trails will be removed, the impacted habitat restored, and new Primitive Trails constructed around the sensitive habitat in accordance with MSCP Subarea Plan design standards.

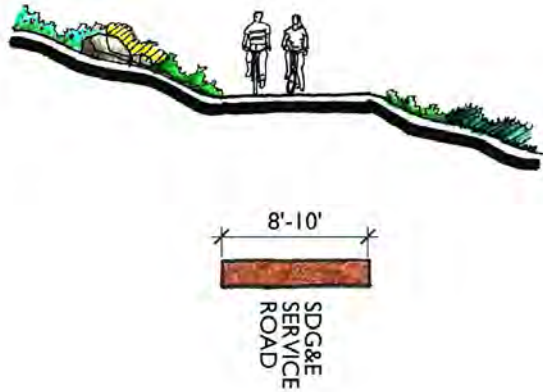
**Design Standards**

Width	Existing varies, new trails 2.5 feet
Surface	Native Earth
Modes	<ul style="list-style-type: none"> <li>• Bicycles</li> <li>• Pedestrians</li> </ul>

Refer to *Chapter 5: Landscape Architecture, Community Design & Outdoor Lighting Design Plan* for specific plant palettes by Village.

**Exhibit 4.14.6: Primitive Trail**





The SDG&E Service Road is an existing native earth road of varying widths crossing through the southern Habitat Preserve utilized by SDG&E to access the existing power lines and towers. The road is also suitable for recreational use by pedestrians and bicyclists.

**Design Standards**

Width	Existing
Surface	Native Earth
Modes	<ul style="list-style-type: none"> <li>• Bicycles</li> <li>• Pedestrians</li> </ul>

Refer to *Chapter 5: Landscape Architecture, Community Design & Outdoor Lighting Design Plan* for specific plant palettes by Village.

**Exhibit 4.14.7: SDG&E Service Road**

# Chapter 5:

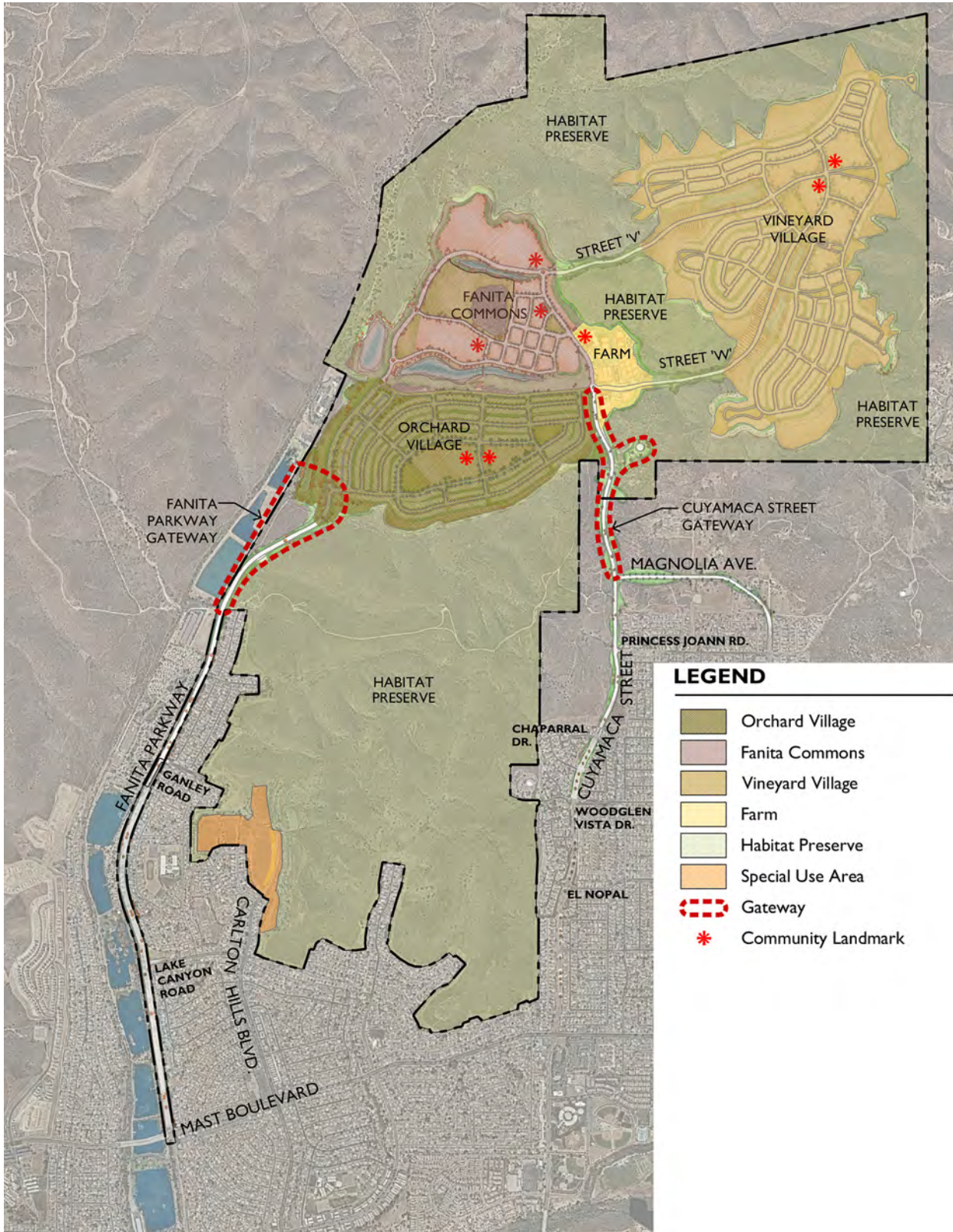
## Landscape Architecture, Community Design & Outdoor Lighting Design Plan

### 5.1 Community Organization and Landscape Theme

The design theme for Fanita Ranch reflects Santee’s unique heritage and is represented in many forms, from farm-themed Villages to a celebration of the site’s ecological resources outside of the Villages. The community has been organized to provide a transition from naturalized open space areas to neighborhoods within an agricultural setting, giving the impression of a small community that has emerged from an agrarian heritage. The community is organized by a series of experiences, as illustrated in *Exhibit 5.1: Community Organization*, including the following organizational elements:

- Gateways
- Landmarks
- Villages
- Habitat Preserve
- Farm

*Exhibit 5.2: Fanita Ranch Illustrative Plan*, depicts Fanita Ranch’s organization and landscape theme, its connections to the larger Santee community and hundreds of acres of preserved natural open space. The City of Santee is designated a Tree City USA by the Arbor Day Foundation in partnership with the United States Forest Service and the National Association of State Foresters. In support of this designation, Fanita Ranch includes a robust tree planting program that will be implemented throughout the community. Gateways and landmarks within open space areas take advantage of existing landforms, natural features, and scenic vistas to provide natural orientation and wayfinding. At the gateways to Fanita Ranch, the naturalistic landscape gradually transitions, giving way to authentic working agricultural fields and orchards. The Farm, at the center of the community, remains a focal point, and each Village reflects the importance of the Farm through a unique agricultural theme. Beyond the fields and orchards, neighborhoods include an eclectic mix of architecture, reflective of typical California farm communities. The emphasis is on an Americana-style of architecture that reinforces the farm design theme. For a more detailed description of the proposed community-wide landscape palette, refer to *Section 5.5: Landscape Palette*.

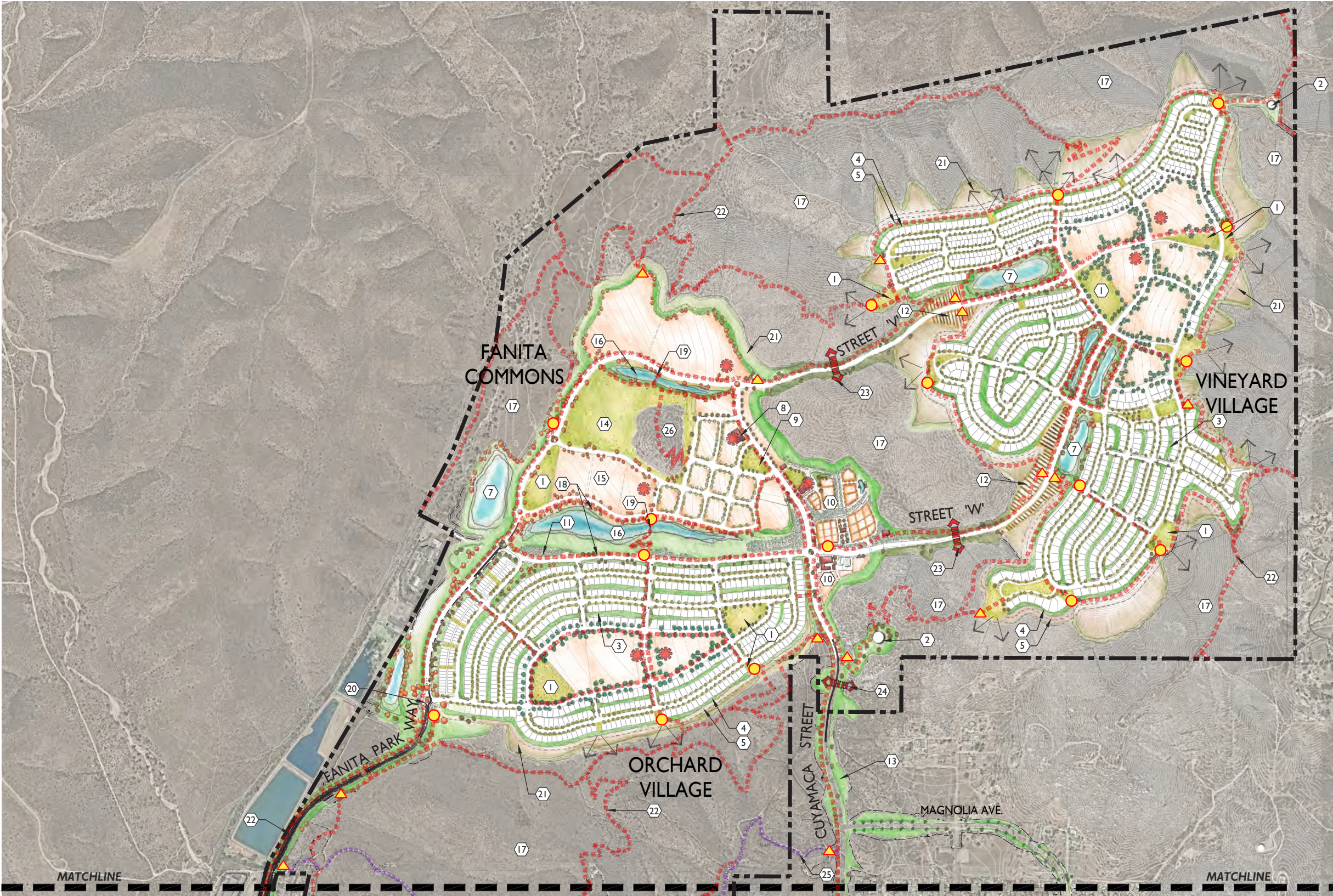


For illustrative purposes only; final design may vary.

**Exhibit 5.I: Community Organization**

⊕ not to scale





- LEGEND**
- ① Neighborhood and Mini Parks
  - ② Water Reservoir
  - ③ Interior Slope Erosion Control Planting
  - ④ FMZ Zone 1 Planting
  - ⑤ FMZ Zone 2
  - ⑥ *Item Intentionally Deleted*
  - ⑦ Water Quality Basin (Typ.)
  - ⑧ Fire Station Site
  - ⑨ Village Green
  - ⑩ Farm
  - ⑪ Orchard (Typ.)
  - ⑫ Vineyard (Typ.)
  - ⑬ Cuyamaca Gateway w/ Informal Oak/ Chaparral Style Planting
  - ⑭ Community Park
  - ⑮ School Site
  - ⑯ Riparian Enhancement and Preserve Area
  - ⑰ Habitat Preserve
  - ⑱ Linear Park
  - ⑲ Pedestrian Bridge
  - ⑳ Fanita Gateway with Informal Riparian Style Planting
  - ㉑ Preserve Revegetation Area
  - ㉒ Trail
  - ㉓ At-grade Wildlife Crossing
  - ㉔ Below Grade Wildlife Crossing
  - ㉕ SDG&E Service Road
  - ㉖ Community Park Passive Area
- Community Landmark
  - View Point
  - Trail
  - SDG&E Service Road
  - Trailhead
  - Potential Trail Access Point
  - Wildlife Crossing

Note: For clarity, not all uses and elements are shown or labeled.

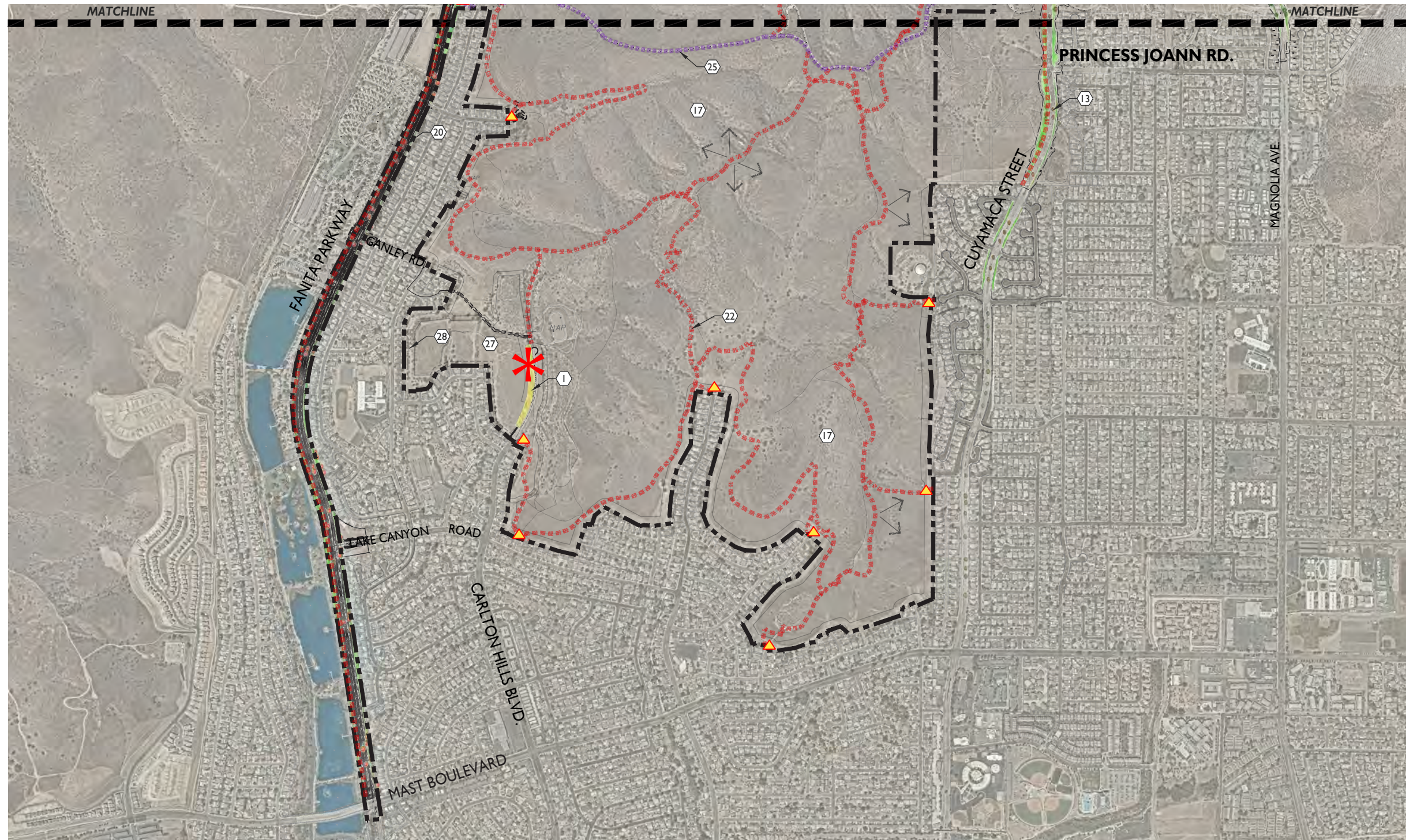
Match Line: See Exhibit 5.2b

not to scale For illustrative purposes only; final design may vary.

**Exhibit 5.2a: Fanita Ranch Illustrative Plan (North)**



Match Line: See Exhibit 5.2a



**LEGEND**

- ① Neighborhood and Mini Parks
- ⑬ Cuyamaca Gateway w/ Informal Oak/Chaparral Style Planting
- ⑰ Habitat Preserve
- ⑳ Fanita Gateway with Informal Riparian Style Planting
- ㉒ Trail
- ㉕ SDG&E Service Road
- ㉗ Special Use Area
- ㉘ Special Use Area Screening Landscape
- Trail
- SDG&E Service Road
- Trailhead
- ▲ Potential Trail Access Point
- \* Trail Staging Area

Note: For clarity, not all uses and elements are shown or labeled.

**Exhibit 5.2b: Fanita Ranch Illustrative Plan (South)**

For illustrative purposes only; final design may vary. ⊕ not to scale



## 5.2 Gateways

Gateways announce entry into Fanita Ranch, with a gateway sequence at two main entries as described in the following sections. Rather than traditional architectural and signage statements for gateways, entry to Fanita Ranch pays homage to the rural, agrarian heritage of the land through the use of the native and agrarian landscape.

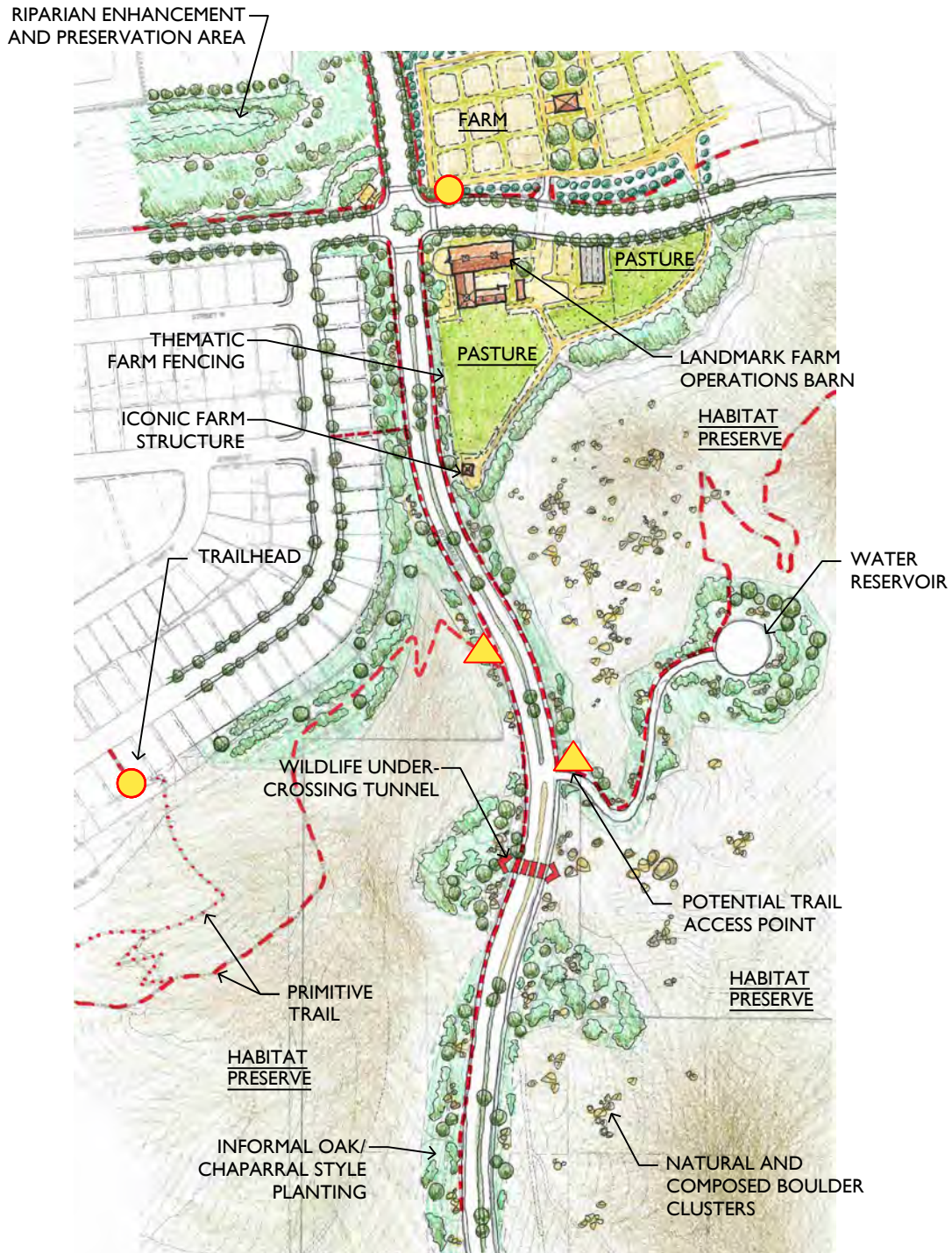
### 5.2.1 Cuyamaca Street Gateway

Cuyamaca Street provides access into the Specific Plan Area. *Exhibit 5.3: Cuyamaca Street Gateway Concept* depicts the visitors' first impressions of the Fanita Ranch community. Upon entering the community, the roadway is designed to preserve and enhance the natural hillsides and rock outcroppings. The roadway passes through the natural terrain to respect slopes and landforms to the greatest extent possible.



Landscaping along roadway edges is designed to reflect the natural setting and preserve views toward significant landforms through limited and informal planting patterns that harmonize with the natural vegetation. Just beyond the most significant rock formation, the roadway begins to slope downward and gives way to views of the Farm in the distance. The roadway landscaping begins to transition to post and rail fencing indicative of an agricultural landscape. Orchard landscaping begins to replace native vegetation and a barn structure announces the Farm and entry into the community.

Community signage will be incorporated into the landscape as rock-outcropping or farm-themed signage. A roundabout with thematic landscaping in its center will define the first intersection and subtle farm-themed wayfinding signage will direct visitors to one of three Villages. The rear elevation of some homes in Orchard Village will be visible from Cuyamaca Gateway and will be enhanced with additional elevation treatments, view fencing and orchard-themed landscaping as appropriate.



Note: Refer to Exhibit 4.13: Trails Map for detail regarding trail types and widths.

For illustrative purposes only; final design may vary.

### Exhibit 5.3: Cuyamaca Street Gateway Concept

⊕ not to scale

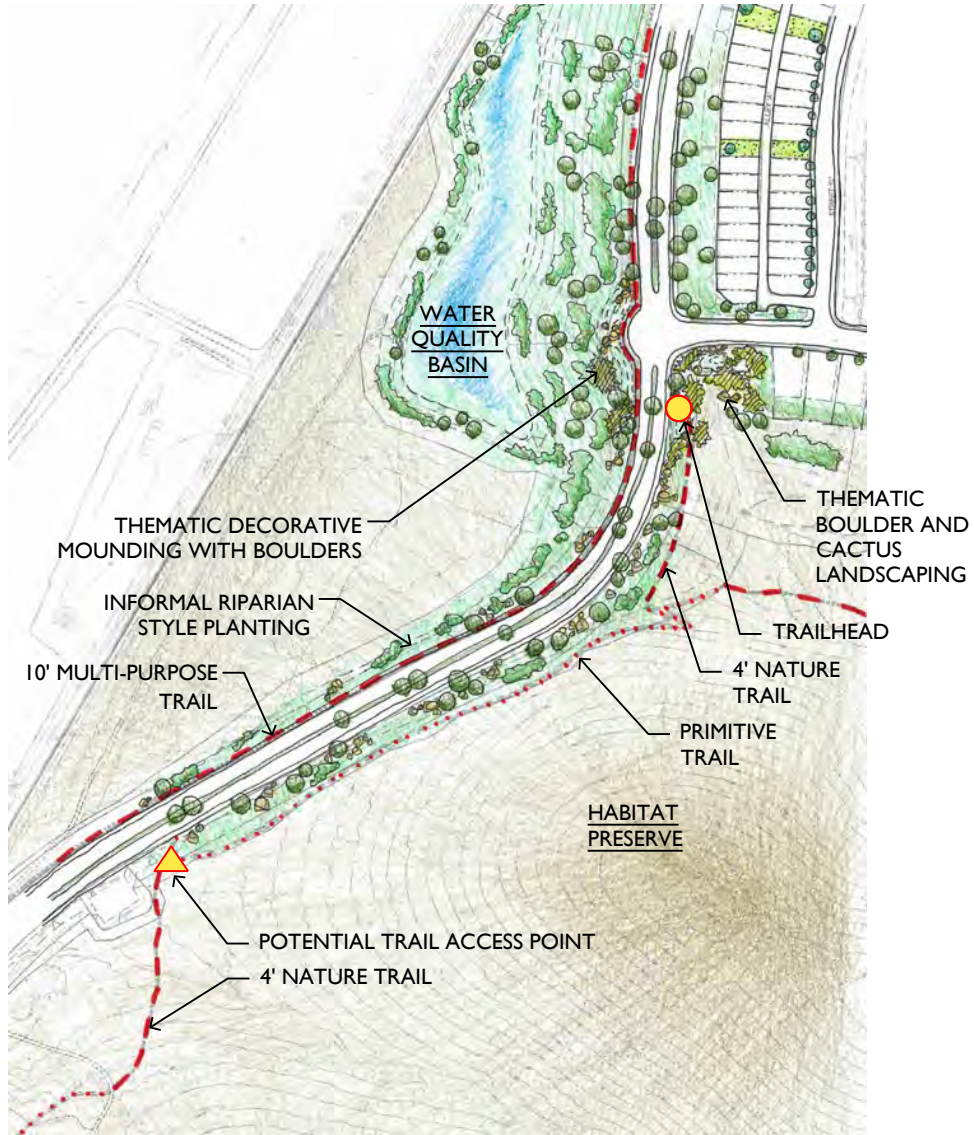
## 5.2.2 Fanita Parkway Gateway

Fanita Parkway also provides access into the Specific Plan Area. *Exhibit 5.4: Fanita Parkway Gateway Concept* maintains the existing roadways rural character by limiting new landscaping and creating informal clusters of trees to preserve views to Santee Lakes. Selected plant species focus on enhancing the existing landscape and views of adjacent existing neighbors. Beyond the existing neighborhoods, plantings of native species recreate the natural habitats that occur within the Specific Plan Area to celebrate the natural resources in the area.



At the southwest edge of the Orchard Village, roadway landscaping transitions to stacked stone walls, post and rail fencing and orchard trees. Community signage is incorporated into the landscape, such as a rock-outcropping or farm-themed signage. A roundabout at Street “A” featuring one or more large specimen trees and subtle farm-themed wayfinding signage will direct visitors to one of three Villages. The rear elevations of homes in Orchard Village visible from Fanita Parkway will be enhanced with additional elevation treatments, view fencing, and orchard-themed landscape as appropriate.





Note: Refer to Exhibit 4.13: Trails Map for detail regarding trail types and widths.

For illustrative purposes only; final design may vary.

### Exhibit 5.4: Fanita Parkway Gateway Concept

 not to scale

## 5.3 Landmarks

Landmarks assist in orientation within the community, particularly at key intersections and nodes to help people identify where they are within the community. *Exhibit 5.1: Community Organization* identifies the location of proposed landmarks within the community. Landmarks may consist of iconic buildings, building tower elements, thematic structures or significant landscape features that are consistent with the farm theme. Examples of appropriate landmarks are provided in *Exhibit 5.5: Conceptual Landmark Imagery*.

## 5.4 Villages

Villages represent the developed portions of the Fanita Ranch community and are designed to provide a unique, individual theme consistent with the overall agrarian design theme. Within each Village, the landscape palette, street furniture and architecture support the Village design theme. *Exhibit 5.1: Community Organization* identifies the three Villages, which are named according to their intended design theme and are described in the following sections.







**Exhibit 5.5: Conceptual Landmark Imagery**



### 5.4.1 Fanita Commons

Fanita Commons serves as the main “common village” for all of Fanita Ranch. With the Farm as its focal point, orchards, vineyards, fields, and a large event barn serve as defining elements of this Village. A Village Green, located across from the Farm, provides the main community gathering space. This public gathering space will serve as an extension of the Farm, allowing farm activities such as farmers’ markets and harvest festivals to spill into the Village Center. *Exhibit 5.2: Fanita Ranch Illustrative Plan, Exhibit 5.6: Fanita Commons Illustrative Plan and Exhibit 5.7: Fanita Commons Imagery* illustrate some of the key landscape and site design concepts for Fanita Commons including the following:







- Create a Village Green with landscaping materials and street furniture consistent with the farm design theme. The Village Green is designed and sized to include open areas and flexible spaces that support community events such as farmers’ markets, harvest festivals, outdoor movies and more.
- Maintain strong visual connection between the Village Green and the passive portion of the Community Park.
- Promote walkability in Fanita Commons by providing shade and other pedestrian amenities such as water fountains, benches, and street furniture that are consistent with the farm design theme.
- Install edible landscapes along trails and sidewalks, where appropriate, to create an “AgMeander” that connects the Farm to other areas of Fanita Commons including the school site, Community Park, Active Adult neighborhood and Village Green.
- Use iconic structures to serve as landmarks and assist with wayfinding.
- Provide a pedestrian bridge across the southerly drainage to connect Fanita Commons with Orchard Village.



Note: Refer to Exhibit 4.13: Trails Map for detail regarding trail types and widths.

**LEGEND**

-  Community Landmark
-  Trailhead
-  Potential Trail Access Point
-  Trail

For illustrative purposes only; final design may vary.

**Exhibit 5.6: Fanita Commons Illustrative Plan**

 not to scale





**Exhibit 5.7: Fanita Commons Imagery**



In support of a consistent Village theme, the Fanita Commons plant palette provides a unified list of trees, shrubs, succulents, and ground covers. *Exhibit 5.8: Fanita Commons Plant Palette* identifies specified plants that can be selected for use in public or publicly viewable spaces.

## **FANITA COMMONS PLANT PALETTE**

**SCIENTIFIC NAME / Common Name**

*(\*) Denotes a native cultivar that shall not be used adjacent to Habitat Preserve.*

### **General Landscape Trees**

GEIJERA PARVIFLORA / Australian Willow

JACARANDA MIMOSIFOLIA / Jacaranda

RHUS LANCEA / African Sumac

### **Street Trees - Residential Collector**

GEIJERA PARVIFLORA / Australian Willow

JACARANDA MIMOSIFOLIA / Jacaranda

KOELREUTERIA BIPINNATA / Chinese Flame Tree

### **Street Trees - Village Collector and Streets**

CASSIA SPLENDIDA 'GOLDEN' / Golden Wonder Cassia

CERCIS CANADENSIS 'FOREST PANSY' / Forest Pansy Eastern Redbud

KOELREUTERIA PANICULATA / Golden Rain Tree

### **Street Trees - Residential Streets**

LIQUIDAMBER STYRACIFLUA / Sweet Gum

CASSIA SPLENDIDA 'GOLDEN' / Golden Wonder Cassia

CERCIS CANADENSIS 'FOREST PANSY' / Forest Pansy Eastern Redbud

### **Park and Village Green Trees**

ALMUS RHOMBIFOLIA / White Alder

CERCIS CANADENSIS 'FOREST PANSY' / Forest Pansy Eastern Redbud

CINNAMOMUM CAMPHORA / Camphor Tree

FRAXINUS UDHEI/Shamel Ash

JACARANDA MIMOSIFOLIA / Jacaranda

KOELREUTERIA PANICULATA / Golden Rain Tree

LIQUIDAMBAR STYRACIFLUA / Sweet Gum

PLATANUS RACEMOSA / California Sycamore

## **Exhibit 5.8: Fanita Commons Plant Palette**

## FANITA COMMONS PLANT PALETTE (CONT.)

### SCIENTIFIC NAME / Common Name

*(\*) Denotes a native cultivar that shall not be used adjacent to Habitat Preserve.*

### School Site Trees

CASSIA SPLENDIDA 'GOLDEN' / Golden Wonder Cassia  
PLATANUS ACERIFOLIA / London Plane  
JACARANDA MIMOSIFOLIA / Jacaranda  
MAGNOLIA GRANDIFLORA / Southern Magnolia  
ULMUS PARVIFOLIA / Chinese Elm

### Active Adult Residential Site Trees

GEIJERA PARVIFLORA / Australian Willow  
CERCIS CANADENSIS 'FOREST PANSY' / Forest Pansy Eastern Redbud  
MAGNOLIA GRANDIFLORA / Southern Magnolia  
ULMUS PARVIFOLIA / Chinese Elm

### Succulents and Cacti

AGAVE AMERICANA / Century Plant  
AGAVE X 'BLUE GLOW' / Blue Glow Agave  
ALOE ARBORESCENS / Torch Aloe  
DASYLIRION WHEELERII / Grey Desert Spoon  
HESPERALOE PARVIFLORA / Red Yucca

### Screening Shrubs

CEANOETHUS X 'CONCHA' / Concha California Lilac\*  
HETEROMELES ARBUTIFOLIA / Toyon  
PITTOSPORUM TENUIFOLIUM 'SILVER SHEEN' / Tawhiwhi  
PRUNUS CAROLINIANA 'BRIGHT 'N TIGHT' / Carolina Laurel

### Ornamental Shrubs and Perennials

ABELIA X GRANDIFLORA 'SHERWOODII' / Dwarf Abelia  
BOUGAINVILLEA SP. / Bougainvillea (To be maintained per Fire Protection Plan)  
CEANOETHUS G. 'ANCHOR BAY' / Anchor Bay Ceanothus\*  
CISTUS SP. / Rockrose

## Exhibit 5.8: Fanita Commons Plant Palette (cont.)

## FANITA COMMONS PLANT PALETTE (CONT.)

SCIENTIFIC NAME / Common Name

*(\*) Denotes a native cultivar that shall not be used adjacent to Habitat Preserve.*

### Ornamental Shrubs and Perennials (Cont.)

GALVEZIA SPECIOSA / Island Bush Snapdragon

LANTANA SP. / Lantana

LAVANDULA STOECHAS / Spanish Lavender

LEUCOPHYLLUM SP. / Texas Ranger

MYRTUS COMMUNIS 'COMPACTA' / Dwarf Myrtle

RHAPHIOLEPIS SP. / Indian Hawthorn

### Ornamental Grasses or Grass-like Plants

ARMERIA MARITIMA / Common Thrift

BULBINE FRUTESCENS / Stalked Bulbine

CHONDROPETALUM TECTORUM / Small Cape Rush

DIANELLA CAERULEA 'CASSA BLUE' / Cassa Blue Flax Lily

FESTUCA GLAUCA / Blue Fescue

PHORMIUM TENAX VAR. / New Zealand Flax

### Groundcovers

CEANOTHUS 'CENTENNIAL' / Centennial Lilac\*

CRASSULA MULTICAVA / Fairy Crassula

DYMONDIA MARGARETAE / Dymondia

FRAGARIA CHILOENSIS / Ornamental Strawberry

GREVILLEA LANIGERA 'MT. TAMBORITHA' / Mt. Tamboritha Grevillea

LANTANA X 'NEW GOLD' / New Gold Lantana

MYOPORUM PARVIFOLIUM 'PINK' / Pink Myoporum

### Vines

DISTICTUS SP. / Trumpet Vine

JASMINUM SP. / Jasmine

WISTERIA SINENSIS / Wisteria

---

## Exhibit 5.8: Fanita Commons Plant Palette (cont.)

## FANITA COMMONS PLANT PALETTE (CONT.)

SCIENTIFIC NAME / Common Name

*(\*) Denotes a native cultivar that shall not be used adjacent to Habitat Preserve.*

### Shade Tolerant Plants

COPROSMA REPENS / Mirror Plant

MAHONIA EURYBRACTEATA 'SOFT CARESS' / Soft Caress Mahonia

PHILODENDRON SP. / Philodendron

POLYSTICHUM MUNITUM / Western Sword Fern

RIBES VIBURNIFOLIUM / Catalina Current

SANSEVIERIA TRIFASCIATA / Mother-in-Law's Tongue

### Notes:

1. Proposed plant palettes are intended to convey a consistent theme throughout a Village or planning area. They are not all encompassing and may be adjusted to conform to final design style and site conditions.
2. Refer to *Exhibit 5.15: Community Streets Plant Palette* for the Fanita Parkway landscape palette.
3. Refer to *Exhibit 5.17: Edible/Medicinal Plant Palette* for "AgMeander" and edible landscapes palette.
4. Landscaping adjacent to Wildland Urban Interface areas must be fire resistant and be consistent with the Fire Protection Plan.

---

## Exhibit 5.8: Fanita Commons Plant Palette (cont.)



### 5.4.2 Orchard Village

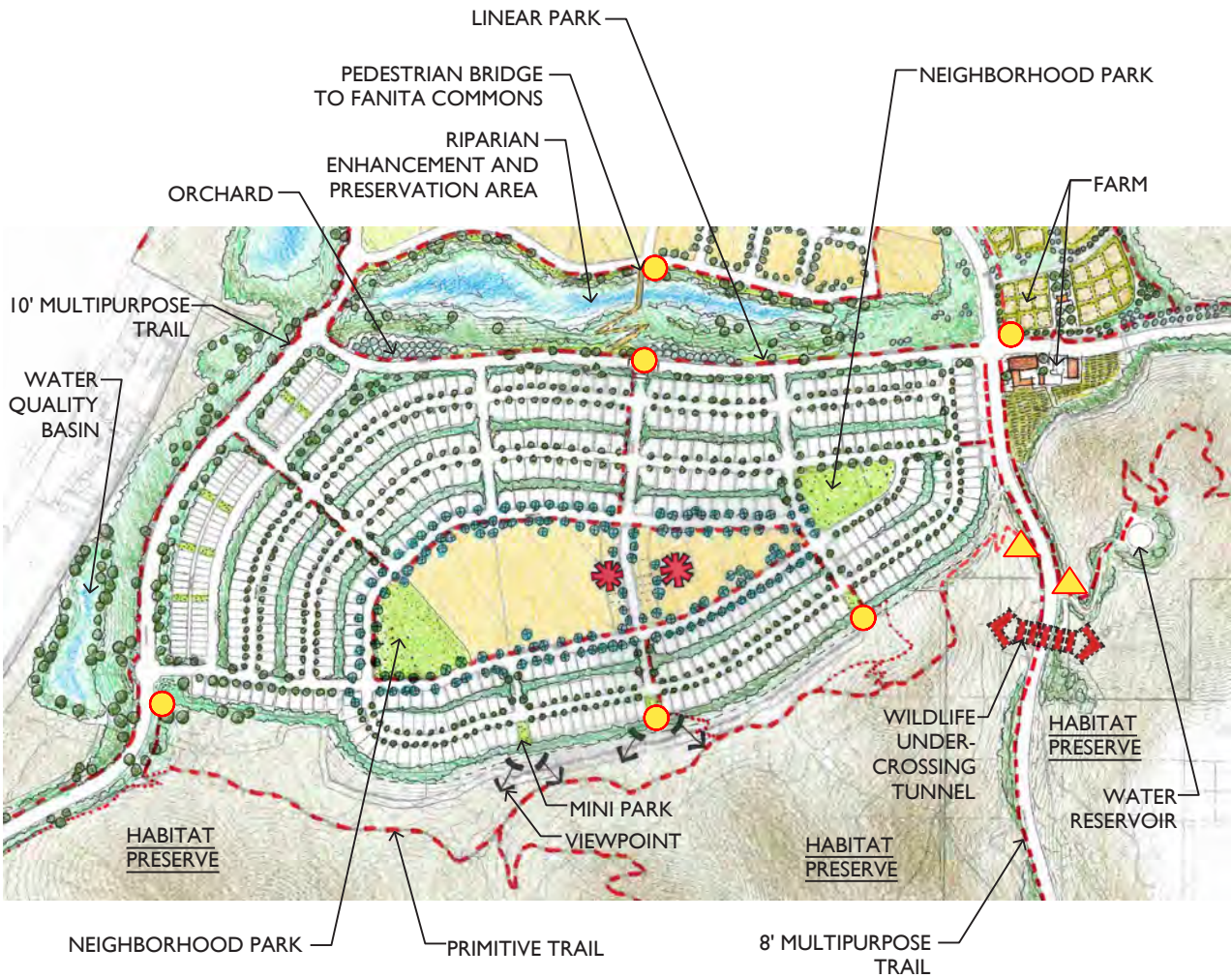
Orchard Village, located south of Fanita Commons, includes orchards that extend from the Farm as its defining design element. Orchard Village is geographically and topographically separated from Fanita Commons, but will be physically connected by roadways, trails and a pedestrian bridge. *Exhibit 5.9: Orchard Village Illustrative Plan* and *Exhibit 5.10: Orchard Village Imagery* illustrate some of the key landscape elements for Orchard Village including the following:



- Extend orchards from the Farm to the southerly side of the southerly riparian area and along roadways within Orchard Village.
- Design orchard plantings north of the riparian areas to be visible from Fanita Commons and establish the orchard design theme.
- Promote walkability in Orchard Village by providing shade and other pedestrian amenities such as benches and water fountains consistent with a farm design theme.
- Install orchard trees and edible landscaping along trails and sidewalks, where appropriate, to extend the “AgMeander” educational and recreational trail from the Farm and Fanita Commons. Refer to *Section 7.3.5: AgMeander* for additional information.
- Use iconic structures typically associated with orchards to serve as landmarks and assist with wayfinding.
- Provide access for tractors and other orchard maintenance equipment to ensure orchards are authentic, well maintained and sustainable.









Refer to *Exhibit 5.11: Orchard Village Plant Palette* for a comprehensive listing of plants for this Village.



Note: Refer to Exhibit 4.13: Trails Map for detail regarding trail types and widths.

**LEGEND**

-  Community Landmark
-  Trailhead
-  Potential Trail Access Point
-  Trail
-  Viewpoint
-  Wildlife Crossing

*For illustrative purposes only; final design may vary.*

 not to scale

**Exhibit 5.9: Orchard Village Illustrative Plan**





**Exhibit 5.10: Orchard Village Imagery**

## ORCHARD VILLAGE PLANT PALETTE

### SCIENTIFIC NAME / Common Name

*(\*) Denotes a native cultivar that shall not be used adjacent to Habitat Preserve.*

### General Landscape Trees

ARBUTUS X 'MARINA' / Marina Strawberry Tree  
CUPANIOPSIS ANACARDIOIDES / Carrotwood  
LAGERSTROEMIA HYBRID / Crepe Myrtle  
PLATANUS RACEMOSA / California Sycamore

### Street Trees - Residential Collector

ARBUTUS X 'MARINA' / Marina Strawberry Tree  
CUPANIOPSIS ANACARDIOIDES / Carrotwood  
GEIJERA PARVIFLORA / Australian Willow  
PLATANUS RACEMOSA / California Sycamore

### Street Trees - Residential Street

ARBUTUS X 'MARINA' / Marina Strawberry Tree  
GEIJERA PARVIFLORA / Australian Willow  
HANDROANTHUS IMPETIGINOSUS / Pink Trumpet Tree

### Street Tree - Village Street

HYMENOSPORUM FLAVUM / Sweetshade  
PLATANUS ACERIFOLIA CULT. / London Plane Tree Cultivars  
ZELKOVA SERRATA 'VILLAGE GREEN' / Sawleaf Zelkova

### Street Tree - Private Residential Driveway

BUXUS SEMPERVIRENS 'GREEN TOWER' / Green Tower Boxwood  
EUGENIA MYRTIFOLIA 'ORANGE TWIST' / Bush Cherry  
ILEX VOMITORIA 'WILL FLEMING' / Yaupon  
RHAPHIOLEPIS INDICA 'MAJESTIC BEAUTY' / Indian Hawthorn

### Interior Slopes Trees

ARBUTUS X 'MARINA' / Marina Strawberry Tree  
CERCIS OCCIDENTALIS / Western Redbud  
ERYOBOTRYA DEFLEXA / Bronze Loquat  
RHUS LANCEA / African Sumac

## Exhibit 5.11: Orchard Village Plant Palette



## ORCHARD VILLAGE PLANT PALETTE (CONT.)

### SCIENTIFIC NAME / Common Name

*(\*) Denotes a native cultivar that shall not be used adjacent to Habitat Preserve.*

### Neighborhood and Mini Park Trees

ALBIZIA JULIBRISSIN / Mimosa Tree  
ERYOBOTRYA DEFLEXA / Bronze Loquat  
HANDROANTHUS IMPETIGINOSUS / Pink Trumpet Tree  
LAGERSTROEMIA HYBRID / Crepe Myrtle  
PISTACIA CHINENSIS / Chinese Pistache  
PLATANUS RACEMOSA / California Sycamore  
QUERCUS AGRIFOLIA / Coast Live Oak  
ZELKOVA SERRATA 'VILLAGE GREEN' / Sawleaf Zelkova

### Linear Park Trees

ALNUS RHOMBIFOLIA / White Alder  
CERCIS OCCIDENTALIS / Western Redbud  
PLATANUS RACEMOSA / California Sycamore  
POPULUS FREMONTII / Fremont Cottonwood  
QUERCUS AGRIFOLIA / Coast Live Oak  
SALIX GOODDINGII / Black Willow  
SALIX LASIOLEPIS / Arroyo Willow

### Succulents and Cacti

AEONIUM CANARIENSE / Giant Velvet Rose  
ALOE MACULATA / Soap Aloe  
ALOE X 'BLUE ELF' / Blue Elf Aloe  
CRASSULA OVATA / Jade Plant  
CYLINDROPUNTIA PROLIFERA / Coastal Cholla  
OPUNTIA LITTORALIS / Coastal Prickly Pear  
OPUNTIA ORICOLA / Chaparral Prickly Pear

### Screening Shrubs

PODOCARPUS M. 'MAKI' / Shrubby Yew Plant (To be maintained per FPP)  
PRUNUS CAROLINIANA 'BRIGHT 'N TIGHT' TM / Carolina Laurel  
RHAMNUS CALIFORNICA 'EVE CASE' / California Coffeeberry\*

## Exhibit 5.11: Orchard Village Plant Palette (cont.)

## ORCHARD VILLAGE PLANT PALETTE (CONT.)

### SCIENTIFIC NAME / Common Name

*(\*) Denotes a native cultivar that shall not be used adjacent to Habitat Preserve.*

### Ornamental Shrubs and Perennials

ABULITON SP. / Flowering Maple  
BUDDLEJA SP. / Butterfly Bush  
BUXUS MICROPHYLLA / Littleleaf Boxwood  
IVA HAYESIANA / San Diego Poverty Weed  
NANDINA SP. / Heavenly Bamboo  
PITTIOSPORUM T. 'WHEELER'S DWARF' / Wheeler's Dwarf Mock Orange  
PRUNUS CAROLINIANA 'BRIGHT 'N TIGHT' / Carolina Laurel  
RHAPHIOLEPIS / Indian Hawthorn  
RUSSELIA EQUISETIFORMIS / Coral Fountain  
VERBENA SP. / Verbena

### Ornamental Grasses or Grass-like Plants

DIANELLA REVOLUTA 'LITTLE REV' / Little Rev Flax Lily  
DIETES 'LEMON DROP' / Lemon Drop Fortnight Lily  
HELICOTRICHON SEMPERVIRENS / Blue Oat Grass  
IRIS DOUGLASIANA / Douglas Iris  
JUNCUS PATENS / California Gray Rush  
LOMANDRA LONGIFOLIA 'SEA BREEZE' / Dwarf Mat Rush  
TULBAGHIA SP. / Society Garlic

### Groundcovers

BACCHARIS P. 'PIGEON POINT' / Dwarf Coyote Bush\*  
COPROSMA 'KIRKII' / Creeping Mirror Plant  
FRAGARIA CHILOENSIS / Ornamental Strawberry  
LANTANA MONTEVIDENSIS / Purple Trailing lantana  
MYOPORUM PARVIFOLIUM 'PINK' / Pink Myoporum  
SENECIO SP. / Blue Chalk Sticks

---

## Exhibit 5.11: Orchard Village Plant Palette (cont.)

## ORCHARD VILLAGE PLANT PALETTE (CONT.)

SCIENTIFIC NAME / Common Name

*(\*) Denotes a native cultivar that shall not be used adjacent to Habitat Preserve.*

### Vines

CLEMATIS ARMANDII / Evergreen Clematis

LONICERA SP. / Honeysuckle

MACFADYENA UNGUIS-CATI / Cat's Claw Vine

### Shade Tolerant Plants

BUXUS X 'CHICAGOLAND GREEN' / Glencoe Boxwood

CYRTOMIUM FALCATUM / Holly Fern

FATSIA JAPONICA / Japanese Aralia

NANDINA DOMESTICA VARIETIES / Heavenly Bamboo

PITTOSPORUM CRASSIFOLIUM / Karo Mock Orange

POLYSTICHUM MUNITUM / Western Sword Fern

Notes:

1. Proposed plant palettes are intended to convey a consistent theme throughout a Village or planning area. They are not all encompassing and may be adjusted to conform to final design style and site conditions.
2. Refer to *Exhibit 5.15: Community Streets Plant Palette* for the Fanita Parkway and Cuyamaca Street landscape palettes.
3. Refer to *Exhibit 5.17: Edible/Medicinal Plant Palette* for "AgMeander" and edible landscapes palette.
4. Landscaping adjacent to Wildland Urban Interface Areas must be fire resistant and be consistent with the Fire Protection Plan.

---

## Exhibit 5.11: Orchard Village Plant Palette (cont.)

### 5.4.3 Vineyard Village

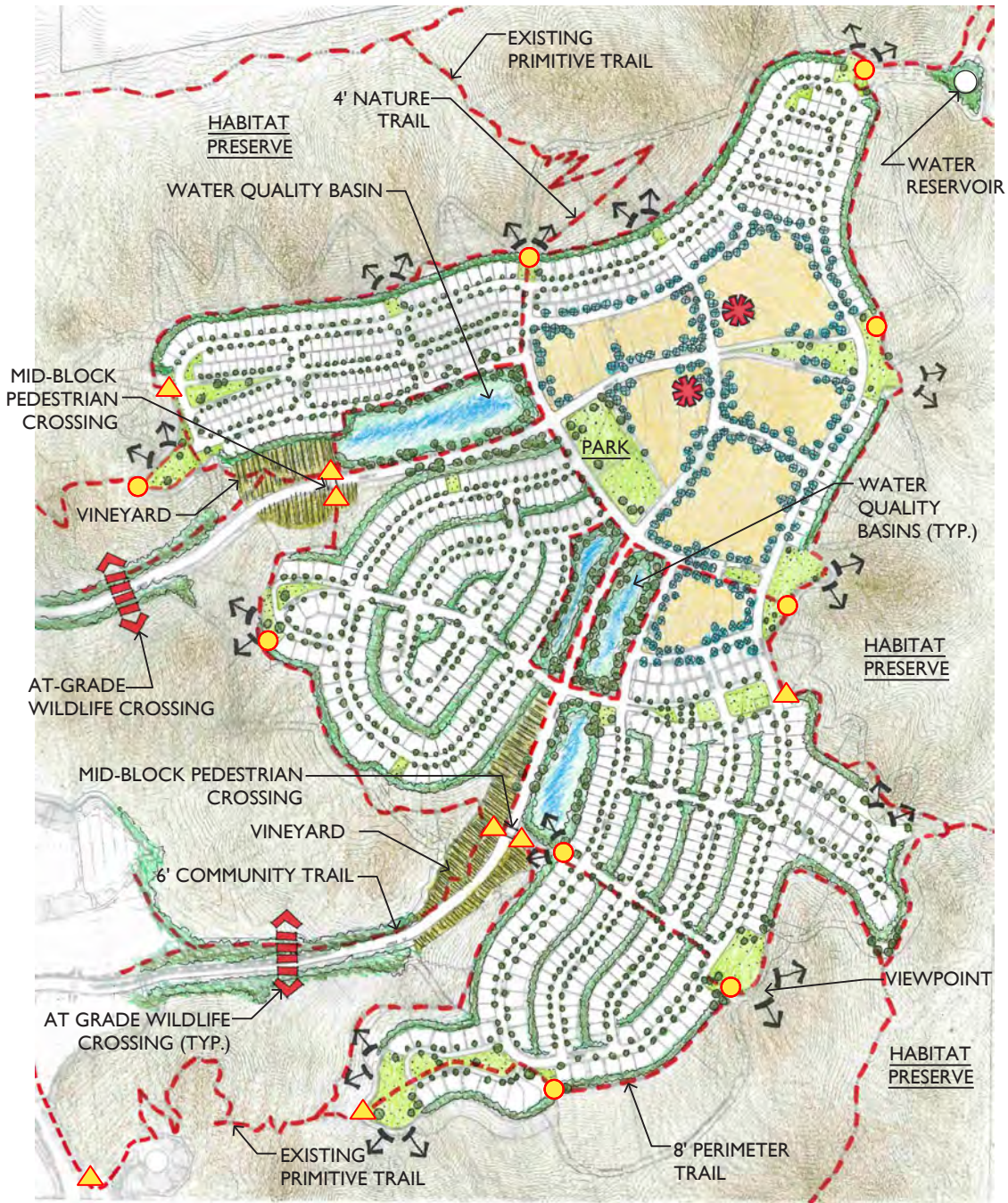
Vineyard Village, located east of Fanita Commons and the Farm, includes vineyards that extend from the edge of the Habitat Preserve up the slopes along the Village access roads. The rising vineyards will highlight the topographical change from Fanita Commons to the top of Vineyard Village. *Exhibit 5.12: Vineyard Village Illustrative Plan* and *Exhibit 5.13: Vineyard Village Imagery* illustrate some of the key landscape elements for Vineyard Village, including the following:

- Extend vineyards from the street entry up the open space slopes.
- Promote walkability of the Vineyard Village by providing a network of trails, paths and walks, including an 8-foot wide trail around the perimeter of the Village.
- Allow community paths and trails to pass through and alongside the vineyards as a part of the AgMeander.
- Use iconic structures, materials and equipment to serve as landmarks and assist with wayfinding.
- Provide access for trucks, tractors and other farm equipment to ensure that the vineyards are viable and sustainable.

Refer to *Exhibit 5.14: Vineyard Village Plant Palette* for a listing of plants for public or publicly viewable spaces in this Village.














Note: Refer to Exhibit 4.13: Trails Map for detail regarding trail types and widths.

**LEGEND**

-  Community Landmark
-  Trailhead
-  Potential Trail Access Point
-  Trail
-  Viewpoint
-  Wildlife Crossing

For illustrative purposes only; final design may vary.

**Exhibit 5.12: Vineyard Village Illustrative Plan**

 not to scale





**Exhibit 5.13: Vineyard Village Imagery**

## VINEYARD VILLAGE PLANT PALETTE

### SCIENTIFIC NAME / Common Name

*(\*) Denotes a native cultivar that shall not be used adjacent to Habitat Preserve.*

### General Landscape Trees

CERCIDIUM X 'DESERT MUSEUM' / Palo Verde

CHILOPSIS LINEARIS CULT. / Desert Willow Cultivars

PODOCARPUS GRACILIOR / Fern Pine (To be maintained per Fire Protection Plan)

### Street Trees - Residential Collectors (Street "X" and portions of Streets "V" and "W")

LIQUIDAMBAR STYRACIFLUA / Sweet Gum

LOPHOSTEMON CONFERTUS / Brisbane Box

MAGNOLIA GRANDIFLORA 'RUSSET' / Russet Southern Magnolia

### Street Trees - Residential Streets

BRACHYCHITON POPULNEUS / Bottle Tree

LIQUIDAMBAR STYRACIFLUA / Sweet Gum

ULMUS PARVIFOLIA 'TRUE GREEN' / True Green Elm

### Street Trees - Split Residential Streets

LOPHOSTEMON CONFERTUS / Brisbane Box

MAGNOLIA GRANDIFLORA 'MAJESTIC BEAUTY' / Southern Magnolia

ULMUS PARVIFOLIA 'TRUE GREEN' / True Green Elm

### Interior Slopes Trees

CHILOPSIS LINEARIS CULT. / Desert Willow Cultivars

X CHITALPA TASHKENTENSIS / Chitalpa

QUERCUS ILEX / Holly Oak

### Neighborhood and Mini Parks Trees

BRACHYCHITON POPULNEUS / Bottle Tree

FRAXINUS UHDEI / Shamel Ash

CERCIDIUM X 'DESERT MUSEUM' / Palo Verde

CERCIS OCCIDENTALIS / Western Redbud

CHILOPSIS LINEARIS CULT. / Desert Willow Cultivars

CUPANIOPSIS ANACARDIOIDES / Carrotwood

## Exhibit 5.14: Vineyard Village Plant Palette



## VINEYARD VILLAGE PLANT PALETTE (CONT.)

### SCIENTIFIC NAME / Common Name

*(\*) Denotes a native cultivar that shall not be used adjacent to Habitat Preserve.*

### Neighborhood and Mini Park Trees (cont.)

MAGNOLIA GRANDIFLORA / Southern Magnolia

PISTACIA CHINENSIS / Chinese Pistache

QUERCUS ILEX / Holly Oak

QUERCUS SUBER / Cork Oak

TIPUANA TIPU / Tipu Tree

X CHITALPA TASHKENTENSIS / Chitalpa

### Succulents and Cacti

AGAVE ATTENUATA / Foxtail Agave

AGAVE PARRYI / Parry's Agave

AGAVE WEBERI / Weber's Agave

ALOE NOBILIS / Gold Tooth Aloe

ALOE PLICATILIS / Fan Aloe

ALOE VERA / Medicinal Aloe

EUPHORBIA TIRUCALLI / Sticks on Fire

OPUNTIA VIOLACEA 'SANTA RITA' / Purple Prickly Pear\*

### Screening Shrubs

CEANOTHUS X 'CONCHA' / Concha California Lilac\*

PITTOSPORUM TENUIFOLIUM 'SILVER SHEEN' / Tawhiwhi

RHAMNUS CALIFORNICA 'EVE CASE' / California Coffeeberry\*

### Ornamental Shrubs and Perennials

CALLIANDRA CALIFORNICA / Baja Fairy Duster

CEANOTHUS CYANEUS (SCARIFIED) / NCN

CISTUS LADANIFER / Crimson-Spot Rockrose

EREMOPHILA MACULATA 'VALENTINE' / Valentine Emu Bush

ESCALLONIA SP. / Escallonia Varieties

LAVANDULA DENTATA / French Lavender

PITTOSPORUM TOBIRA / Mock Orange

ROSA SP. / Rose

WESTRINGIA FRUTICOSA / Coast Rosemary

## Exhibit 5.14: Vineyard Village Plant Palette (cont.)



## VINEYARD VILLAGE PLANT PALETTE (CONT.)

### SCIENTIFIC NAME / Common Name

*(\*) Denotes a native cultivar that shall not be used adjacent to Habitat Preserve.*

### Ornamental Grasses or Grass-like Plants

ANIGOZANTHOS SP. / Kangaroo Paw  
ARISTIDA PURPUREA / Purple Threeawn  
DIANELLA TASMANICA `VARIEGATA` / Flax Lily  
FESTUCA MAIREI / Atlas Fescue  
HEMEROCALLIS SP. / Daylily  
KNIPHOFIA UVARIA / Red Hot Poker

### Groundcovers

ACHILLEA `MOONSHINE` / Moonshine Yarrow\*  
CEANOETHUS G. HORIZONTALIS / Carmel Creeper  
CISTUS SP. / Rockrose  
COTONEASTER DAMMERI `LOWFAST` / Lowfast Bearberry  
ERIGERON KARVINSKIANUS / Santa Barbara Daisy  
GREVILLEA LANIGERA `COASTAL GEM` / Coastal Gem Grevillea  
MYOPROUM X `PACIFICA` / Trailing Myoporum  
THYMUS SP. / Thyme

### Vines

PANDOREA JASMINOIDES / Bower Vine  
TRACHELOSPERMUM JASMINOIDES / Star Jasmine  
VITIS CALIFORNICA `WALKER RIDGE` / California Wild Grape\*

### Shade Tolerant Plants

DIANELLA CULTIVARS / Flax Lily Cultivars  
DIETES / Fortnight Lily  
FRAGARIA CHILOENSIS / Ornamental Strawberry  
HEUCHERA SP. / Coral Bells  
MYRICA CALIFORNICA / Pacific Wax Myrtle  
RHAMNUS CALIFORNICA `MOUND SAN BRUNO` / California Coffeeberry\*  
SYMPHORICARPOS ALBA / Snowberry

## Exhibit 5.14: Vineyard Village Plant Palette (cont.)

Notes:

1. Proposed plant palettes are intended to convey a consistent theme throughout a Village or planning area. They are not all encompassing and may be adjusted to conform to final design style and site conditions.
2. Refer to *Exhibit 5.15: Community Streets Plant Palette* for the Fanita Parkway landscape palette.
3. Refer to *Exhibit 5.17: Edible/Medicinal Plant Palette* for “AgMeander” and edible landscapes palette.
4. Landscaping adjacent to Wildland Urban Interface Area to be fire resistant and be consistent with the Fire Protection Plan.



**Exhibit 5.14: Vineyard Village Plant Palette (cont.)**



## 5.5 Community-Wide Street Landscape Palette

The community-wide plant palettes developed for Fanita Ranch, as depicted in *Exhibits 5.15 through 5.17*, offer a unique and diversified range of materials. While respecting the existing native landscape and addressing fire management requirements, the plant palette includes water-wise ornamental plants, agricultural plants, edible ornamental plants, native plants, and interesting accent plants. Careful attention has been given to develop a palette that is drought tolerant and non-invasive, complements the natural surroundings and provides a rich aesthetic quality to the various Villages. Landscape and irrigation in Fanita Ranch shall comply with the applicable provisions of the Guidelines for Implementation of the City of Santee Water Efficient Landscape Ordinance.

Certain areas within Fanita Ranch require special attention to landscaping to address site-specific conditions. These conditions include fuel modification zones, riparian habitat areas, the protected Habitat Preserve and revegetation areas. Planting techniques and palettes for these areas shall comply with the requirements of the Fanita Ranch Fire Protection Plan (FPP) and Preserve Management Plan.

Village-specific plant palettes are discussed in the previous sections. The following plant palettes have been provided for the remaining areas of the Specific Plan to establish the intended design character for roadways, public spaces, common areas, exterior slopes within Fuel Modification Zones 1 and 2 and areas within the development area that will be restored as part of the Habitat Restoration Plan. All proposed plant materials must comply with the FPP.

Additional plant materials that are complementary to the following palettes may be permitted, provided they are non-invasive, have received a recommendation of approval from the Master Developer and have been approved by Santee Fire Department. Following are representative plant palettes for streets, street fuel modification zone landscaping, exterior slope fuel modification zone landscaping and edible landscaping.



## COMMUNITY STREETS PLANT PALETTE

SCIENTIFIC NAME / Common Name

*(\*) Denotes a native cultivar that shall not be used adjacent to Habitat Preserve.*

### **FANITA PARKWAY**

#### **Median Trees**

ARBUTUS X 'MARINA' / Marina Strawberry Tree  
KOELREUTERIA BIPINNATA / Chinese Flame Tree  
PLATANUS RACEMOSA / California Sycamore

#### **Roadside Fuel Modification Zones and Median Trees**

ARBUTUS X 'MARINA' / Marina Strawberry Tree  
CASSIA SPLENDIDA 'GOLDEN' / Golden Wonder Cassia  
JACARANDA MIMOSIFOLIA / Jacaranda  
KOELREUTERIA PANICULATA / Golden Rain Tree  
PLATANUS ACERIFOLIA CULTIVARS / London Plane Tree

#### **Roadside Fuel Modification Zones and Median Shrubs**

AEONIUM CANARIENSE / Giant Velvet Rose  
ALOE X 'BLUE ELF' / Blue Elf Aloe  
ARMERIA MARITIMA / Common Thrift  
BULBINE FRUTESCENS / Stalked Bulbine  
CEANOETHUS G. 'ANCHOR BAY' / Anchor Bay California Lilac\*  
CISTUS SP. / Rockrose  
LANTANA SP. / Lantana  
LAVANDULA STOECHAS / Spanish Lavender  
LEUCOPHYLLUM SP. / Texas Ranger  
PHORMIUM TENAX VAR. / New Zealand Flax  
ROSA SP. / Rose

#### **Roadside Fuel Modification Zones and Median Groundcovers**

ACHILLEA 'MOONSHINE' / Moonshine Yarrow\*  
ARTEMESIA 'CANYON GRAY' / Canyon Gray Sagebrush  
CEANOETHUS G. HORIZONTALIS / Carmel Creeper  
CISTUS SP. / Rockrose  
DYMONDIA MARGARETAE / Dymondia  
FRAGARIA CHILOENSIS / Ornamental Strawberry

### **Exhibit 5.15: Community Streets Plant Palette**



## COMMUNITY STREETS PLANT PALETTE (CONT.)

SCIENTIFIC NAME / Common Name

*(\*) Denotes a native cultivar that shall not be used adjacent to Habitat Preserve.*

### Roadside Fuel Modification Zones and Median Groundcovers (cont.)

LANTANA MONTEVIDENSIS / Purple Trailing Lantana

MYOPORUM PARVIFOLIUM 'PINK' / Pink Myoporum

## CUYAMACA STREET

### Street Trees

ERCIDIUM X 'DESERT MUSEUM' / Desert Museum Palo Verde

CHILOPSIS LINEARIS CULT. / Desert Willow Cultivars

QUERCUS ILEX / Holly Oak

RHUS LANCEA / African Sumac

X CHITALPA TASHKENTENSIS / Chitalpa

### Roadside Fuel Modification Zones and Median Trees

CERCIDIUM X 'DESERT MUSEUM' / Palo Verde

CHILOPSIS LINEARIS CULT. / Desert Willow Cultivars

QUERCUS ILEX / Holly Oak

RHUS LANCEA / African Sumac

X CHITALPA TASHKENTENSIS / Chitalpa

### Roadside Fuel Modification Zones and Median Shrubs, Succulents and Cacti

AGAVE ATTENUATA / Foxtail Agave

CISTANTHE GRANDIFLORA / Rock Purslane

DIANELLA REVOLUTA 'LITTLE REV' / Little Rev Flax Lily

GREVILLEA CULTIVARS / Grevillea Cultivars

IVA HAYESIANA / San Diego Poverty Weed

LAVANDULA DENTATA / French Lavender

TULBAGHIA SP. / Society Garlic

VERBENA SP. / Verbena

### Roadside Fuel Modification Zones and Median Groundcovers

ACHILLEA MILLEFOLIUM / Common Yarrow

BACCHARIS PILULARIS PILULARIS / Dwarf Coyote Bush

## Exhibit 5.15: Community Streets Plant Palette (cont.)

## COMMUNITY STREETS PLANT PALETTE (CONT.)

SCIENTIFIC NAME / Common Name

*(\*) Denotes a native cultivar that shall not be used adjacent to Habitat Preserve.*

### Roadside Fuel Modification Zones and Median Groundcovers (cont.)

COPROSMA 'KIRKII' / Creeping Mirror Plant

LANTANA X 'NEW GOLD' / New Gold Lantana

MYOPORUM X 'PACIFICA' / Trailing Myoporum

SENECIO SP. / Blue Chalk Sticks

### MAGNOLIA AVENUE

#### Street Trees

HYMENOSPORUM FLAVUM / Sweetshade

MAGNOLIA GRANDIFLORA 'RUSSET' / Russet Southern Magnolia

### Roadside Fuel Modification Zones and Median Shrubs

CISTUS SP. / Rockrose

HEMEROCALLIS SP. / Daylily

IRIS DOUGLASIANA / Douglas Iris

LOMANDRA LONGIFOLIA 'SEA BREEZE' / Dwarf Mat Rush

### Roadside Fuel Modification Zones and Median Groundcovers

BACCHARIS PILULARIS 'TWIN PEAKS NO.2' / Dwarf Coyote Bush

COTONEASTER DAMMERI 'LOWFAST' / Lowfast Bearberry

ERIGERON KARVINSKIANUS / Santa Barbara Daisy

THYMUS SP. / Thyme

### RESIDENTIAL COLLECTOR - STREETS "V" & "W" FROM CUYAMACA STREET TO STREET "X"

#### Street Trees

QUERCUS AGRIFOLIA / Coast Live Oak

QUERCUS ILEX / Holly Oak

QUERCUS SUBER / Cork Oak

## Exhibit 5.15: Community Streets Plant Palette (cont.)

## COMMUNITY STREETS PLANT PALETTE (CONT.)

SCIENTIFIC NAME / Common Name

*(\*) Denotes a native cultivar that shall not be used adjacent to Habitat Preserve.*

### Roadside Fuel Modification Zones and Median Trees

CHILOPSIS LINEARIS CULT. / Desert Willow Cultivars

QUERCUS AGRIFOLIA / Coast Live Oak

QUERCUS ILEX / Holly Oak

QUERCUS SUBER / Cork Oak

### Roadside Fuel Modification Zones and Median Shrubs, Succulents and Cacti

CISTUS LADANIFER / Crimson-Spot Rockrose

CYLINDROPUNTIA PROLIFERA / Coastal Cholla

EREMOPHILA MACULATA 'VALENTINE' / Valentine Emu Bush

FESTUCA MAIREI / Atlas Fescue

HERSPERALOE PARVIFLORA / Red Yucca

OPUNTIA LITTORALIS / Coastal Prickly Pear

OPUNTIA ORICOLA / Chaparral Prickly Pear

### Roadside Fuel Modification Zones and Median Groundcovers

BACCHARIS PILULARIS PILULARIS / Dwarf Coyote Bush

CEANOETHUS G. HORIZONTALIS / Carmel Creeper

CRASSULA MULTICAVA / Fairy Crassula

#### Notes:

1. Proposed plant palettes are intended to convey a consistent theme throughout Fanita Ranch. They are not all encompassing and may be adjusted to conform to final design style and site conditions.
2. Landscaping adjacent to Wildland Urban Interface Area shall be fire resistant and be consistent with the Fire Protection Plan.

## Exhibit 5.15: Community Streets Plant Palette (cont.)

## EXTERIOR SLOPES PLANT PALETTE

SCIENTIFIC NAME / Common Name

*(\*) Denotes a native cultivar that shall not be used adjacent to Habitat Preserve.*

### Fuel Management Zone I - Trees

ARBUTUS UNEDO / Strawberry Tree  
ARBUTUS X 'MARINA' / Marina Arbutus  
CHILOPSIS LINEARIS CULT. / Desert Willow Cultivars  
QUERCUS AGRIFOLIA / Coast Live Oak  
QUERCUS ENGELMANNII / Englemann Oak  
QUERCUS ILEX / Holly Oak  
QUERCUS SUBER / Cork Oak

### Fuel Management Zone I - Shrubs/Perennials

ACHILLEA MILLEFOLIUM / Common Yarrow  
CEANOTHUS CYANEUS / Big Pod Ceanothus  
CEANOTHUS G. HORIZONTALIS / Carmel Creeper  
CEANOTHUS MEGACARPUS / Coast Ceanothus  
CEANOTHUS RAMULOSUS 'RODEO LAGOON' / Rodeo Lagoon Ceanothus\*  
CEANOTHUS TOMENTOSUS / Woolly-Leaf Ceanothus  
PRUNUS ILICIFOLIA / Hollyleaf Cherry  
RHAMNUS CALIFORNICA / California Coffeeberry  
RHAMNUS CROCEA / Redberry  
RHAMNUS CROCEA ILICIFOLIA / Hollyleaf Redberry  
RHUS INTEGRIFOLIA / Lemonade Berry  
RHUS LANCEA / African Sumac  
RIBES INDECORUM / White-Flowered Current  
RIBES SPECIOSUM / Fuchsia-Flowering Gooseberry  
RIBES VIBURNIFOLIUM / Evergreen Current  
SAMBUCUS MEXICANA / Mexican Elderberry

### Fuel Management Zone I - Groundcovers

BACCHARIS PILULARIS PILULARIS / Dwarf Coyote Bush  
CEANOTHUS G. HORIZONTALIS/ Ceanothus  
COPROSMA 'KIRKII' / Creeping Mirror Plant  
MYOPORUM PARVIFOLIUM 'PINK' / Pink Myoporum

## Exhibit 5.16: Exterior Slopes Plant Palette



## EXTERIOR SLOPES PLANT PALETTE (CONT.)

SCIENTIFIC NAME / Common Name

*(\*) Denotes a native cultivar that shall not be used adjacent to Habitat Preserve.*

### Fuel Management Zone I - Succulents/Cacti

CYLINDROPUNTIA PROLIFERA / Coast Cholla

DUDLEYA SP. / Dudleya

OPUNTIA LITTORALIS / Coast Prickly Pear

OPUNTIA ORICOLA / Chaparral Prickly Pear

### Herbaceous Plants in Fuel Modification Zones

ELYMUS CONDENSATUS / Giant Wild Rye

ERIOPHYLLUM CONFERTIFOLIUM / Golden Yarrow

ESCHSCHOLZIA CALIFORNICA / California Poppy

GNAPHALIUM CALIFORNICUM / California Everlasting

HELIANTHEMUM SCOPARIUM / Rushrose

LASTHENIA CALIFORNICA / Coast Goldfields

LUPINUS SUCCULENTUS / Arroyo Lupine

NEMOPHILA MENZIESII / Baby Blue Eyes

PLANTAGO ERECTA / Dot-Seed Plantain

STIPA PULCHRA / Purple Needle Grass

Notes:

1. Proposed plant palettes are intended to convey a consistent theme throughout Fanita Ranch. They are not all encompassing and may be adjusted to conform to final design style and site conditions.
2. Landscaping adjacent to Wildland Urban Interface areas must be fire resistant and be consistent with the Fire Protection Plan.



## Exhibit 5.16: Exterior Slopes Plant Palette (cont.)

## EDIBLE / MEDICINAL PLANT PALETTE

### SCIENTIFIC NAME / Common Name

#### Trees

ANACARDIUM OCCIDENTALE / Cashew  
ARBUTUS UNEDO / Strawberry Tree  
CERATONIA SILIQUA / Carob  
CITRUS 'IMPROVED MEYER' / Meyer Lemon  
CITRUS KUMQUAT 'MEIWA' / Meiwa Kumquat  
CITRUS RETICULATA 'GOLD NUGGET' / Gold Nugget Mandarin Orange  
CITRUS X AURANTIIFOLIA 'BEARSS SEEDLESS' / Bearass Seedless Lime  
CITRUS X SINENSIS CULT. / Orange Cultivars  
CITRUS X TANGELO 'MINNEOLA' / Honeybell Tangelo  
DIOSPYROS KAKI 'FUYU' / Fuyu Persimmon  
ERIOBOTRYA JAPONICA / Loquat  
FEIJOA SELLOWIANA / Pineapple Guava  
FICUS CARICA 'MISSION' / Mission Fig  
JUGLANS CALIFORNICA / California Walnut  
LAURUS NOBILIS / Sweet Bay  
MACADAMIA INTERFRIFOLIA / Macadamia Nut  
MALUS DOMESTICA 'HONEYCRISP' / Honeycrisp Apple  
OLEA EUROPAEA VAR. / European Olive (To be maintained per FPP)  
PERSEA AMERICANA 'HASS' / Avocado (To be maintained per FPP)  
PISTACIA VERA / Pistacio  
PRUNUS MARITIMA / Beach Plum  
PUNICA GRANATUM 'WONDERFUL' / Pomegranite  
PYRUS SP. / Pear  
VITEX AGNUS-CASTUS / Chaste Tree

#### Shrubs / Perennials / Succulents

ABELIA GRANDIFLORA VARIETIES / Glossy Abelia  
ALLIUM SP. / Chives  
ALOE VERA / Medicinal Aloe  
ALOYSIA TRIPHYLLA / Lemon Verbena  
ARBUTUS UNEDO 'COMPACTA' / Dwarf Strawberry Tree  
CAMELLIA SINENSIS / Green Tea

### Exhibit 5.17: Edible / Medicinal Plant Palette

## **EDIBLE / MEDICINAL PLANT PALETTE (CONT.)**

SCIENTIFIC NAME / Common Name

### **Shrubs / Perennials / Succulents (cont.)**

CYMBOPOGON CITRATUS / Lemon Grass  
HAMAMELIS VIRGINIANA / Witch Hazel  
SIMMONDSIA CHINENSIS / Jojoba

### **Shrubs / Perennials / Succulents (Cont.)**

LAVANDULA DENTATA / French Lavender  
LAVANDULA STOECHAS / Spanish Lavender  
LYCIUM BARBARUM / Firecracker Gojiberry  
OPUNTIA FICUS-INDICA / Prickly Pear of Nopales  
RIBES RUBRUM 'RED LAKE' / Red Lake Current  
ROSA DAMASCENA / Otto Rose  
SALVIA ELEGANS / Pineapple Sage  
SALVIA OFFICINALIS CULT. / Sage  
SAMBUCUS CANADENSIS 'ADAMS' / Adams Elderberry  
SAMBUCUS NIGRA / Common Elderberry  
THYMUS VULGARIS / English Thyme  
VACCINIUM CORYMBOSUM VAR. / Blueberry

### **Groundcovers**

ACHILLEA MILLEFOLIUM / Yarrow  
ARNICA CHAMISSONIS / Meadow Arnica  
CENTELLA ASIATICA / Gotu Kola  
CHAMAEMELUM NOBILE / Roman Chamomile  
FRAGARIA X ANANASSA VAR. / Strawberry  
HELICHRYSUM ITALICUM / Curry Plant  
MENTHA PIPERITA / Peppermint  
ORIGANUM VULGARE / Italian Oregano  
TARAXACUM OFFICINALE / Dandelion  
THYMUS SERPYLLUM 'MAGIC CARPET' / Magic Carpet Creeping Thyme  
THYMUS X CITRIODORUS 'AUREUS' / Golden Lemon Thyme

---

## **Exhibit 5.17: Edible / Medicinal Plant Palette (cont.)**

## **EDIBLE / MEDICINAL PLANT PALETTE (CONT.)**

**SCIENTIFIC NAME / Common Name**

### **Vines**

PASSIFLORA SP. / Passion Flower

RUBUS SP. / Raspberry Varieties

VITIS CALIFORNICA / California Grape

VITIS SP. / GRAPE Varieties

WISTERIA SINESIS / Wisteria

### Notes:

1. Proposed plant palettes are intended to convey a consistent theme throughout Fanita Ranch. They are not all encompassing and may be adjusted to conform to final design style and site conditions.
2. Landscaping adjacent to Wildland Urban Interface Area shall be fire resistant and be consistent with the Fire Protection Plan.

## **Exhibit 5.17: Edible / Medicinal Plant Palette (cont.)**



## 5.6 Brush Management/Fuel Modification

Characteristic of most communities in Southern California, wildfires within natural open space areas are highly probable events. Community planning, landscaping and maintenance must be planned and designed to minimize loss of life and property when a fire does occur. All landscaping within Fanita Ranch must comply with the Fanita Ranch FPP. All plants within Fanita Ranch shall be selected from the FPP approved plant list. New and existing plants within the designated fire protection zones and street side fuel modification zones shall be planted and maintained in accordance with the FPP. Plants on the FPP prohibited plant list shall not be planted, and existing plants within the development areas that are on the FPP prohibited plant list shall be removed. Refer to *Section 8.6.2.1: Fuel Modification Zones* and Fanita Ranch EIR Appendix P1 for additional detail.

## 5.7 Habitat Restoration Program

The Fanita Ranch project will implement a habitat restoration and enhancement program that will offset impacts to existing biological resources located within the development footprint and generally increase the integrity of ecological systems across the property. Restoration activities will occur in upland and wetland-riparian areas that increase and improve native habitat coverage, which will benefit wildlife in general, and potentially sensitive species such as California gnatcatcher, cactus wren, Quino checkerspot and Hermes copper butterflies, and San Diego fairy shrimp. To accomplish these goals, the program will address issues associated with vernal pools, southern willow scrub, mule fat scrub, and a variety of native upland vegetation communities. Manufactured slopes on the exterior of the development footprint and Fuel Modification Zones will primarily be revegetated with coastal sage scrub, chaparral and cactus species to blend with the adjacent native vegetation and provide additional habitat for key sensitive species.

Moreover, native habitat in the Habitat Preserve will be managed in perpetuity through implementation of a Preserve Management Plan (PMP). The PMP will direct long-term management of preserved biological resources through the enhancement, restoration and maintenance of native vegetation communities, sensitive species, and the local ecosystem for the betterment of the environment and to enhance the quality of life for residents of Santee.

As with all landscaping within the Fanita Ranch community, the design, installation and maintenance of the habitat restoration program will comply with the Fanita Ranch FPP. Proper plant species selection and spacing will restore native habitat while reducing the effects of potential future fire events.

## 5.8 Walls and Fencing

*Exhibit 5.18: Conceptual Wall and Fencing Plan* depicts the location of project-wide theme walls and fences that will reflect the community’s farm theme, provide privacy, and enhance the safety of the residents. The walls and fences shown below are generally representative of the proposed design character; however, wall and fence materials, colors and details may vary by Village but will be complimentary and consistent with the Fanita Ranch agrarian theme. Final wall and fencing specifications to be determined during preparation of detailed Landscape Improvement Plans.

The Fanita Ranch FPP requires the following:

*“Fencing within all lots that are directly adjacent to open space or naturally vegetated areas would be constructed with non-combustible materials (e.g., stone, block), fire rated wood, treated fire-rated vinyl, or SFD [Santee Fire Department] approved materials. In no case would the fence return (closest five feet of fencing to a structure) be constructed of combustible materials.”*

Following are the wall and fence types that occur at Fanita Ranch:

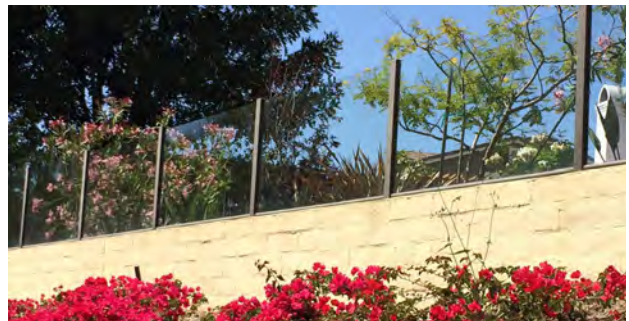
- **Masonry Community Walls:** Reduce noise and provide privacy for residences adjacent to primary streets. Community walls consist of 6-foot high slump block walls and slump block pilasters. Landscaping in front of the wall softens the mass of the wall. Masonry sound walls shall be constructed at the perimeter of the pump stations to provide noise attenuation.
- **View Fences:** Tubular steel or masonry and Plexiglas view fences define the boundary between public and private spaces while allowing visual access to the views from many of the residential lots. Decorative tubular steel fencing 6-foot high is utilized for most conditions. Where sound attenuation or open space fire mitigation is required, a short slump block masonry wall finished to match the community wall, topped with a tempered glass or Plexiglas view screen, is appropriate. Tubular street fences secure stormwater basins as well.



Masonry Community Wall



Tubular Steel View Fence



View Fence

- **Tubular Steel View Fence in Fuel Modification Zones:** Perimeter lots in the Orchard and Vineyard Villages that abut the Habitat Preserve have exceptional views. To keep these views completely open, the 6-foot high view fence will be moved down the slope into the FMZs.

- **Privacy Fencing:** 5-foot 6-inch high wood fencing provides privacy between adjacent residences and from the street. A medium-body stain treatment provides a finished appearance and reduces sun and water bleaching of the wood. All fencing in lots adjacent to native open space shall be constructed of non-combustible materials (fire-rated wood referred to as FRX exterior treated rated wood product (Hoover brand or equivalent)). For interior lots, fencing within 5 feet of a structure must be non-combustible or meet the same fire rating as the structure wall. See the Fanita Ranch FPP Section 6.1.1.1 and Section 6.4.1 for additional details.



Privacy Fencing

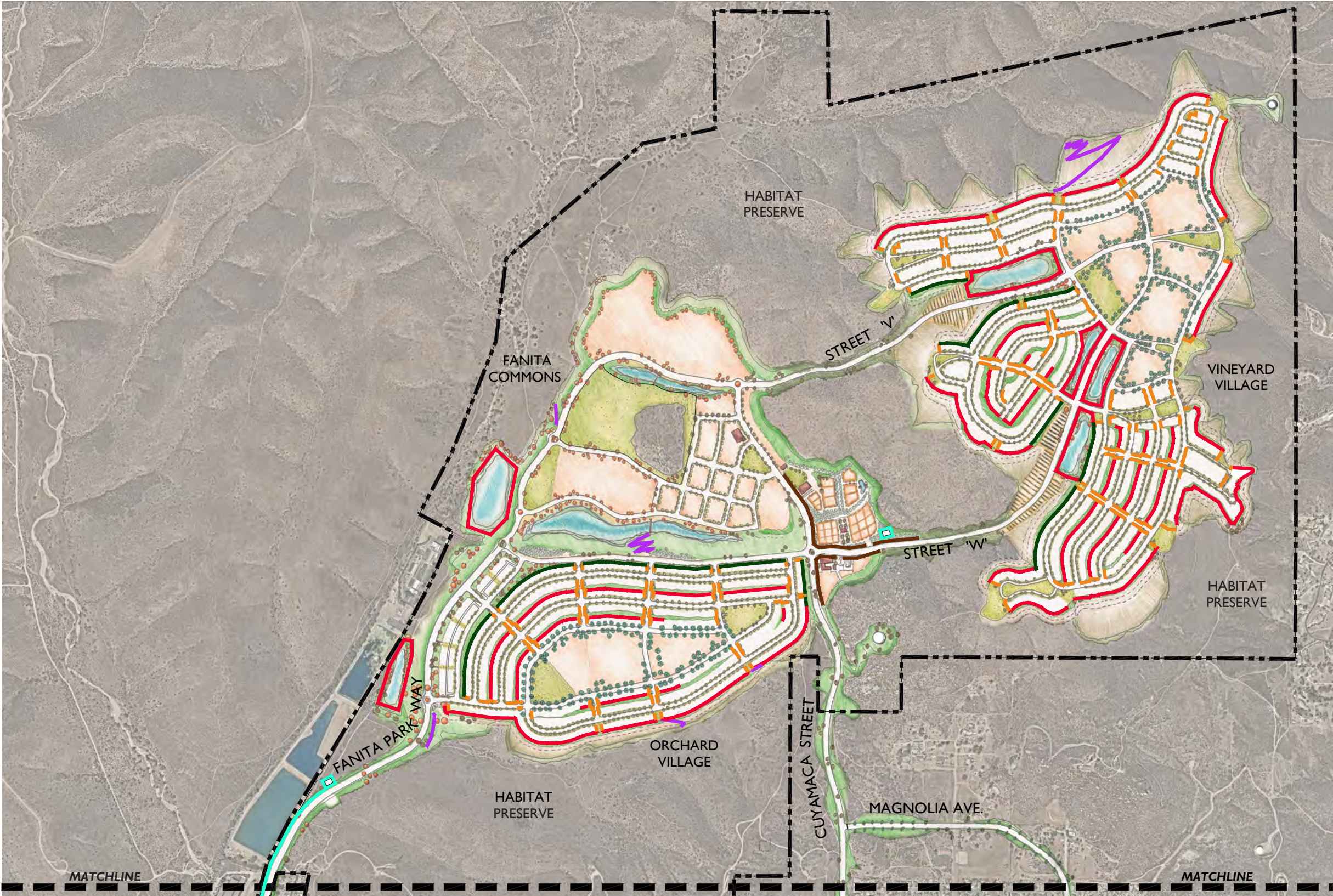
- **Open Space and Trail Fencing:** Peeler log post and rail fencing keeps trail users safe and on approved trails. The 4.5-foot high natural wood fence is treated to resist insects and decay. Wood-look precast concrete split rail fencing is an appropriate option. Open space and trail fencing will be located as needed and only portions are shown on *Exhibit 5.18: Conceptual Wall and Fencing Plan*.



Post and Rail Trail Fencing

- **Special Use Area Security Fencing:** A 6-foot high tubular steel, masonry wall or similar will surround and secure the Special Use area. The wall will help visually blend into the surrounding landscape and provide visual screening.





- LEGEND**
- Masonry Community Wall
  - Tubular Steel View Fence
  - Masonry and Glass View Fence
  - Open Space and Trail Fencing
  - Thematic Farm Fencing
  - Masonry Sound Wall

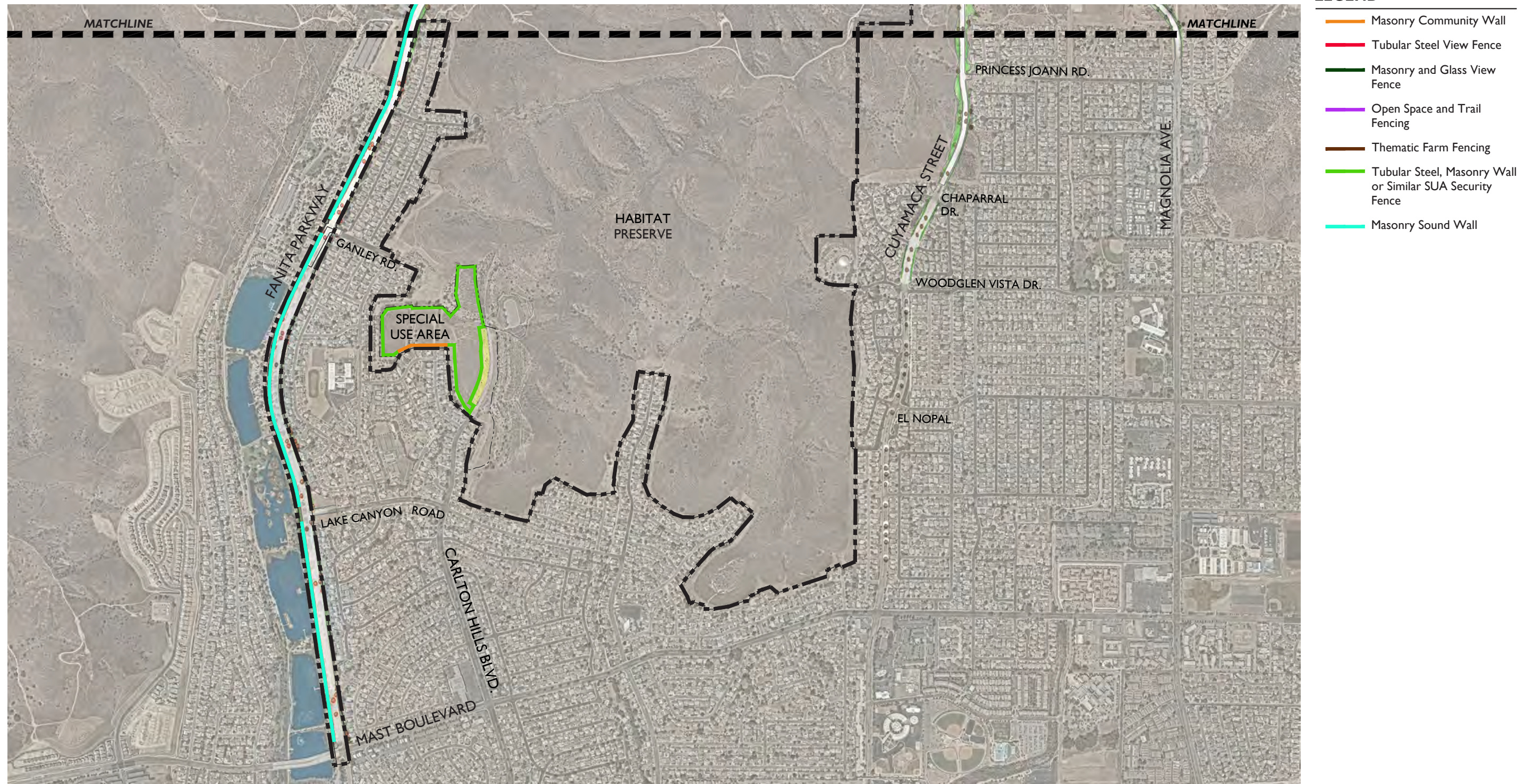
Match Line: See Exhibit 5.18b

⊕ not to scale For illustrative purposes only; final design may vary.

**Exhibit 5.18a: Conceptual Wall and Fencing Plan (North)**



Match Line: See Exhibit 5.18a



- LEGEND**
- Masonry Community Wall
  - Tubular Steel View Fence
  - Masonry and Glass View Fence
  - Open Space and Trail Fencing
  - Thematic Farm Fencing
  - Tubular Steel, Masonry Wall or Similar SUA Security Fence
  - Masonry Sound Wall

**Exhibit 5.18b: Conceptual Wall and Fencing Plan (South)**

For illustrative purposes only; final design may vary.  not to scale



## 5.9 Conceptual Lighting Plan

Outdoor lighting, when implemented in a consistent manner, plays a large role in the visual unification of a community. The Fanita Ranch Conceptual Lighting Plan provides general lighting design guidance for streets, pathways, common open space, recreation areas, buildings, special accent lighting and sign illumination, as conceptually depicted on *Exhibit 5.19: Conceptual Lighting Plan*. Five guiding principles were considered during preparation of this Community Lighting Plan:

1. Provide streets with a safe and desirable level of illumination for motorists and pedestrians without intruding into adjacent residential, riparian and Habitat Preserve areas.
2. Reduce or eliminate light pollution by utilizing low glare and full cutoff light fixtures, lower wattage luminaires and lighting controls to create a “Dark Sky” friendly community.
3. Relate lighting fixtures to the human scale, especially in pedestrian areas.
4. Choose fixtures and luminaires to complement the design and character of the environment in which they are placed.
5. Coordinate with the City of Santee to implement the use of energy efficient fixtures and appropriate technologies.

### Lighting Design Theme

Thematic and special accent lighting design will enhance the architectural and landscape theme within Fanita Ranch, primarily within the Village Centers. Enhanced lighting will vary based upon lighting location and application within each Village Center. Village Center streets should be well lit to encourage evening use and pedestrian activity. Thematic walkway lighting, parking lot lighting and building accent lighting will be utilized to reinforce the community agrarian theme. Lighting may be utilized to create unique landmarks and enhance community gateways. Light fixture images provided herein are for illustrative purposes only. Final fixtures will be selected during the Development Review process.



## Dark Sky

One of the defining characteristics of a community is the visibility of stars in the night sky. Excessive outdoor lighting can brighten the night sky and adversely impact community character, views of the night sky, ecosystems and energy resources. The “Dark Sky” concept will be implemented in Fanita Ranch to minimize light pollution caused by the effects of sky glow, glare and light trespass onto adjacent properties, streets and environmentally sensitive areas, conserve energy use and maintain nighttime safety and security. This will be achieved by: 1) designing lighting according to use; 2) prohibiting certain types of light sources; 3) using appropriate shielding and direction of lighting sources; and 4) enforcing lighting curfews for certain uses.

## General Lighting Guidelines

The Community Lighting Plan provides a conceptual design framework that reinforces the overall visual character of the community and establishes lighting design criteria consistent with the “Dark Sky” concept and lighting guidelines provided herein. Outdoor lighting angle and intensity will be planned for night-time mobility and safety. In general, light fixtures will be designed, spaced and placed to efficiently direct light downward, particularly lighting for streets and parking areas. All outdoor lighting shall be shielded to confine light within the site and prevent glare onto adjacent properties, Habitat Preserve lands, riparian areas and streets.

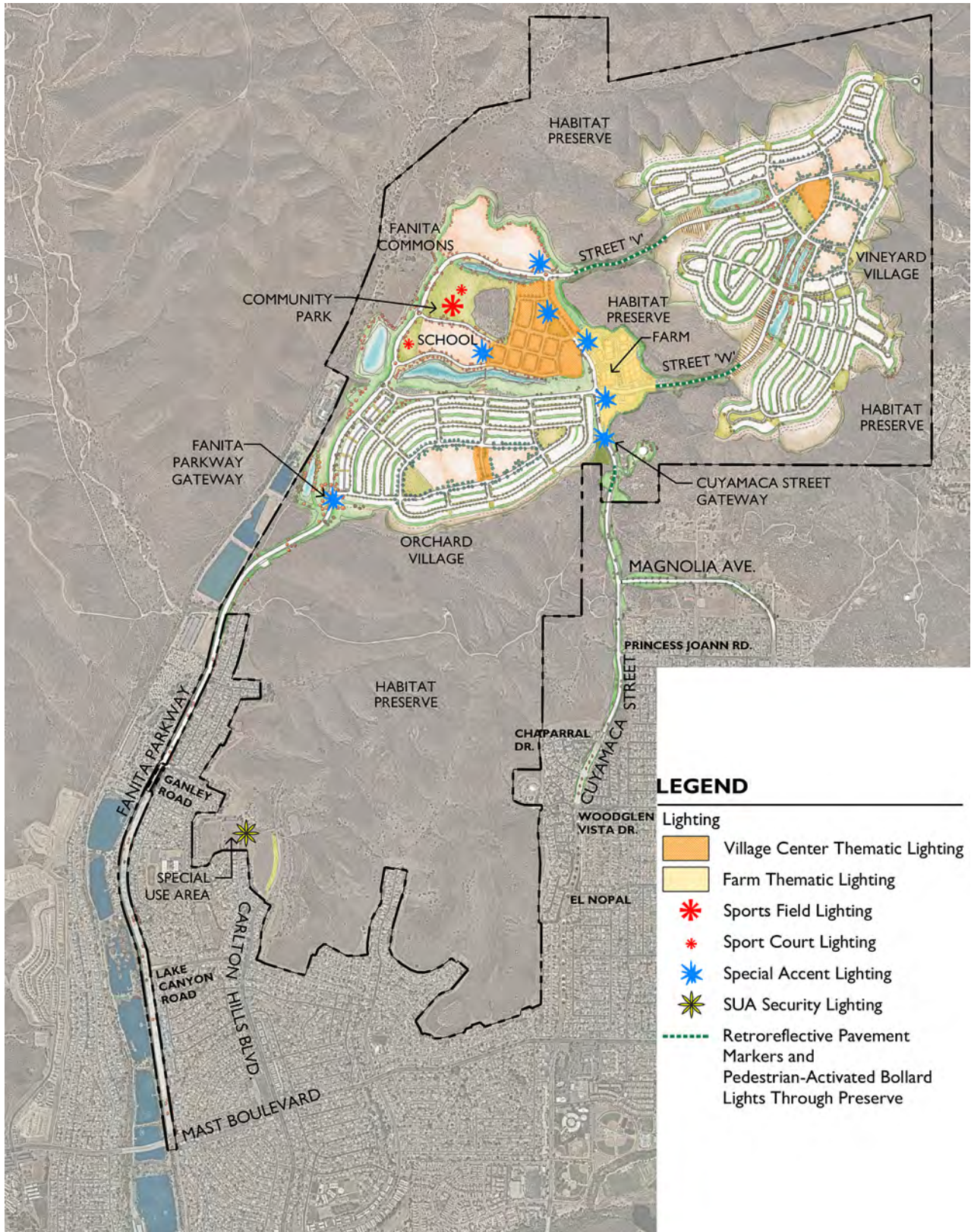
Site-specific lighting shall meet the following requirements:

1. All light fixtures shall conform to the requirements of Title 24 of the California Code of Regulations.
2. Direct lighting shall be shielded from adjacent residential properties, Habitat Preserve lands, riparian areas and other light sensitive receptors.



*For illustrative purposes only; final design may vary.*





**LEGEND**

- Lighting
- Village Center Thematic Lighting
  - Farm Thematic Lighting
  - \* Sports Field Lighting
  - \* Sport Court Lighting
  - \* Special Accent Lighting
  - \* SUA Security Lighting
  - Retroreflective Pavement Markers and Pedestrian-Activated Bollard Lights Through Preserve

*For illustrative purposes only; final design may vary.*

not to scale

**Exhibit 5.19: Conceptual Lighting Plan**



3. Lighting shall be directed to the specific location intended for illumination (e.g., roads, parking areas, walkways and recreation areas).
4. Non-essential lighting and stray light spillover shall be minimized.
5. Low-intensity lamps shall be used except where high-intensity illumination is needed or required.
6. Street light design and spacing shall be consistent with the City of Santee Public Works Standards (1982), as may be amended.

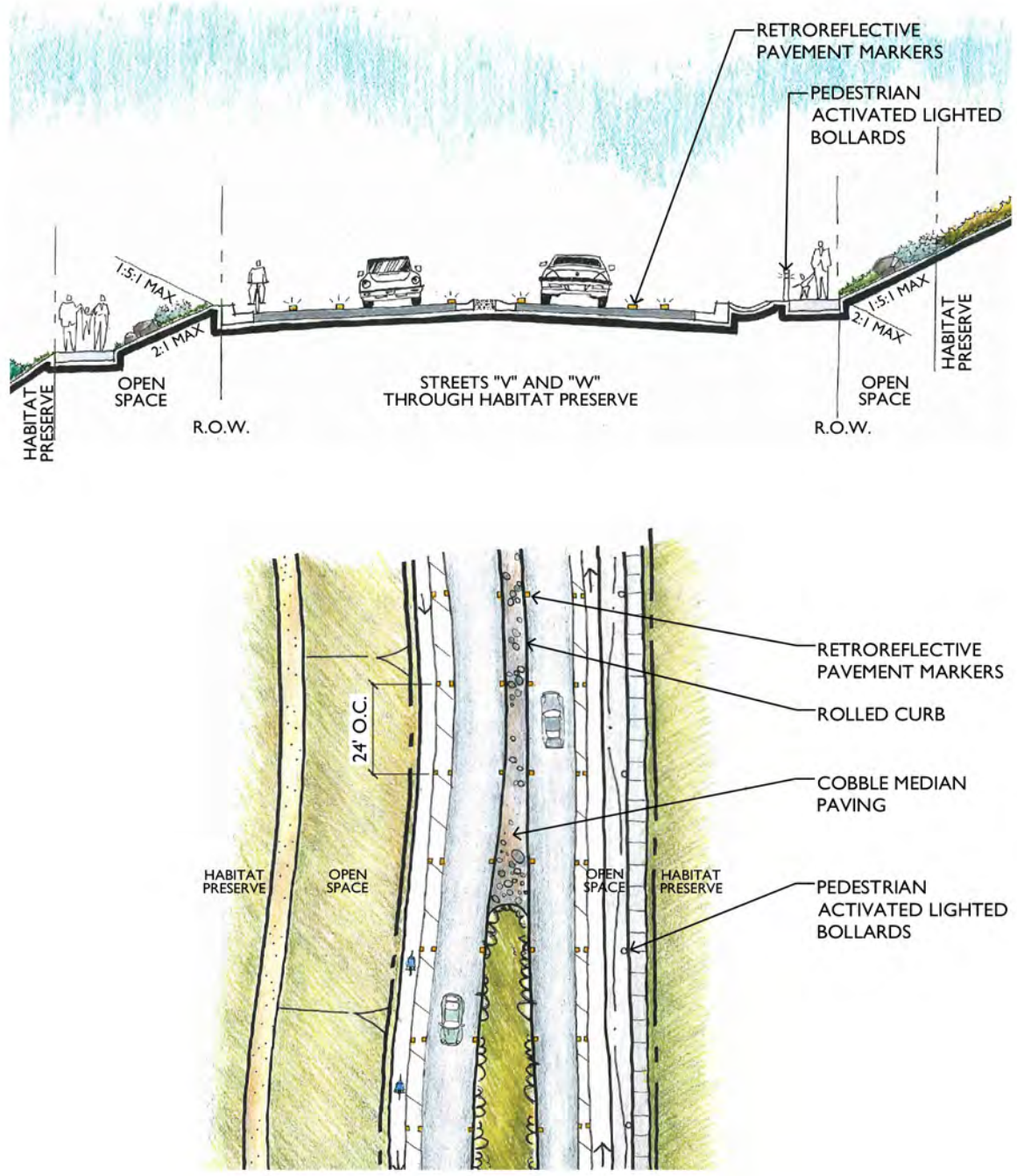
### ***Lighting Within or Adjacent to Habitat Preserve and Other Environmentally Sensitive Areas***

The Community Lighting Plan for Fanita Ranch:

- Eliminates lighting in or adjacent to conserved habitat, except where essential for roadway use, facility use, safety, or security purposes;
- Uses low-pressure sodium illumination sources or other similar technology;
- Does not use low-voltage outdoor or trail lighting, spotlights or bug lights; and
- Shields light sources adjacent to conserved habitat so that the lighting is focused downward.

Consistent with these requirements, lighting within the development areas shall be directed away from adjacent Habitat Preserve, riparian and other natural open space areas to limit light spillage. Low-pressure sodium lights shall be utilized, unless new and/or improved technology is available during project implementation. Fully shielded/full cutoff light fixtures shall be utilized to the extent feasible in areas adjacent to Habitat Preserve and other environmentally sensitive areas.

Streets “V” and “W” connect Fanita Commons and Orchard Village with the Vineyard Village. Portions of these roadways cross the Habitat Preserve at certain locations and are designed to include wildlife crossings. In order to create a safe corridor for automobiles and pedestrians, as well as accommodate nocturnal wildlife movement and enhance the viability of planned wildlife crossings, portions of these roads would be marked with highly reflective pavement markers instead of standard roadside City street lights and include a pedestrian-activated, low-level bollard lighting system. It has been demonstrated that, from an animal’s perspective, the pavement markers mimic a small rock in the landscape and would not negatively impact wildlife movement. Retroreflective Pavement Markers (pursuant to the State of California Department of Transportation specifications) will be spaced 24’ on center on these segments. The following exhibits show an example of how the reflective pavement markers will be incorporated in portions of Streets “V” and “W”.



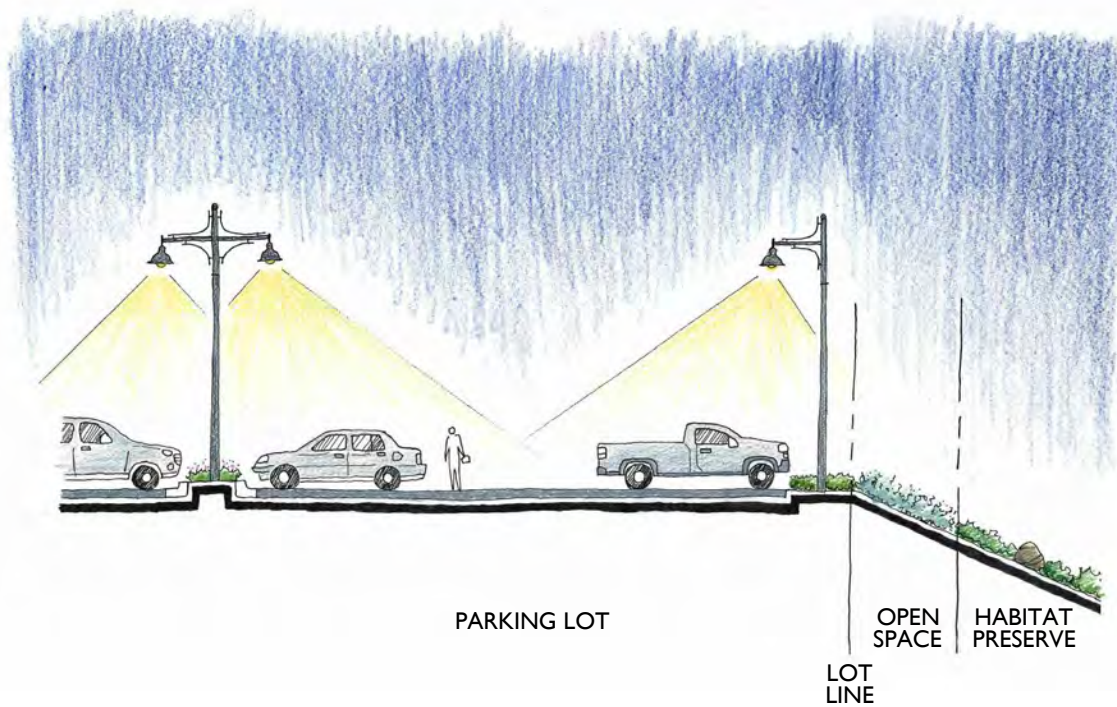
*For illustrative purposes only; final design may vary.*

### Street Lighting

The Fanita Ranch Conceptual Community Lighting Plan complies with the City of Santee Public Works Standards (1982) for street light standards, except as otherwise stated herein. Street lights will be spaced and placed to efficiently direct light downward. Timers or photocell sensors will be incorporated into the light fixtures to reduce energy use. Retroreflective pavement markers, rather than street lights, and a pedestrian-activated bollard lighting system will be used on street segments where wildlife crossings are planned to minimize light impacts on the adjacent Habitat Preserve areas, as previously described herein.

### Common Area and Parking/Loading Area Lighting

Lighting will only be used to provide illumination for the security and safety of on-site areas such as entries, pathways and parking and loading areas. Low intensity fixtures shall be utilized to illuminate walkways and trails to enhance pedestrian safety and comfort. Where appropriate, the lighting pattern and intensity may become more intense at path intersections and vehicular crossings. Parking and service area lighting shall be contained within the area boundaries/enclosure. The design of light fixtures must be architecturally compatible with the main structures.



*For illustrative purposes only; final design may vary.*

### **Park Lighting**

Lighting within community, neighborhood and mini-parks is anticipated. To accommodate night-time use of the Community Park and promote safety and security, lighting within sports fields, sport courts, parking lots and walkways, as well as building security and accent lighting, plaza lighting and signage lighting will be provided. Neighborhood parks and mini-parks are planned for day-time use only. Lighting within these facilities may be limited to walkway and building security lighting. Where playing fields and other recreational areas are to be illuminated to accommodate night-time use, lighting fixtures shall be designed, mounted and directed so that the light beams fall within the playing areas. Direct illumination shall be confined to within the property line of the recreational use. Illumination of the sports fields and other ball fields shall be designed to conform to the recommended practice by the Illuminating Engineering Society of North America (IESNA) for recreational ball fields. Any non-security lighting within the Community Park and other ball fields shall be turned off by 11 p.m. or 30 minutes past the event (whichever is later). Detailed lighting plans and photometric analysis will be required at the improvements site plan level. Specific lighting fixtures and lamps will be determined during the Development Review process.





### **Building Exterior Lighting**

Building exterior lighting shall be designed to minimize glare and light spill. Light fixtures must be consistent with the architectural style of the building. Indirect wall lighting, wall “washing” from concealed fixtures and landscape lighting are encouraged, provided they are subtle and not overly bright. Where appropriate and feasible, motion sensors or timers should be incorporated on exterior fixtures to reduce energy usage.



### **Implementation**

Outdoor lighting will be considered during Development Review and shall be consistent with this Community Lighting Plan. Light fixture specifications, fixture placement and a photometric analysis shall be submitted as part of a Development Review application or in conjunction with street or other improvement plans proposed within or adjacent to Habitat Preserve areas. All community facility and recreation area lighting that may illuminate a residential area between the hours of 11 p.m. and sunrise shall be clearly identified on the site plan.

# Chapter 6:

## Architectural Design Guidelines

The following architectural guidelines provide a general framework for building design to express the desired character of Fanita Ranch, ensure a consistent level of quality and support green building practices. The guidelines are not intended to limit innovative design, but rather provide direction and design criteria that support the vision of a high quality, sustainable community. While not every guideline may be applicable to each building style, building type or site conditions, future builders and architectural designers should attempt to meet the desired intent of these guidelines.

### 6.1 Architectural Styles

Fanita Ranch will incorporate a mix of architectural styles to promote visual interest and diversity and establish a distinct sense of place. Architecture in Fanita Ranch takes its inspiration from the small farm towns found throughout rural areas of California. These small towns evolved over time and include an eclectic mix of architectural styles that respond to the local climate and design trends of the various periods of development throughout California. Below is a list of the appropriate architectural styles for Fanita Ranch:

- Americana - National
- Americana - Traditional
- Americana - Victorian
- Americana - Ranch
- Arts & Crafts - Craftsman
- Arts & Crafts - Foursquare
- Arts & Crafts - Prairie
- Early California - Hacienda
- Early California - Monterey
- Mediterranean Countryside - Andalusian
- Modern - Mid-Century Modern
- Contemporary - Transitional

Because market conditions and homeowner preferences are constantly evolving, additional architectural styles not specifically identified in this Specific Plan are permitted within Fanita Ranch. Site plans, building elevations and a colors and materials palette for residential products shall be reviewed in accordance with the procedures set forth in *Section 10.6.5: Development Review* to ensure that quality design is commensurate with the standards contained in this Specific Plan.

## Americana - National

The National style emerged shortly after the railroads expanded west and allowed for the transport of bulkier and heavier items such as lumber. The National style was the first to implement light balloon or braced farming techniques in lieu of traditional log and sod construction. Homes still maintained simple, rectilinear forms with side-gables roofs or square forms with pyramidal roofs. Rectilinear wings were often added at right angles to the side of the primary building, resulting in the gabled-front-and-wing style commonly found throughout the United States. Frontages include simple stoops or broad covered porches. National style homes are typically covered by wood sheathing and remain simple and utilitarian in style with few adornments. Accents are usually limited to candle sconces and light fixtures that reinforce the rustic theme. Windows are simple and left bare to take advantage of unfiltered natural light. Roofs include metal seam, flat concrete tile or architectural grade composition tile.





## Americana - National Design Elements

Form and Massing	<ul style="list-style-type: none"> <li>• One and two story massing</li> <li>• Simple, rectilinear or square forms</li> <li>• Secondary wings at right angles to primary massing</li> </ul>
Roofs	<ul style="list-style-type: none"> <li>• Simple, gable primary roof forms</li> <li>• Shed roof forms may be located at first floor and porch</li> <li>• 6:12 to 8:12 primary roof pitch</li> <li>• 12” to 24” overhangs</li> <li>• Flat concrete tiles or architectural composition shingles; optional standing seam metal roof</li> </ul>
Exterior Wall Materials	<ul style="list-style-type: none"> <li>• Lap siding or a blend of lap siding and stucco on front elevations, and stucco on other elevations, with board and batten siding accents on gable ends</li> </ul>
Entries	<ul style="list-style-type: none"> <li>• Simple stoop or covered porch</li> <li>• Simple square porch posts or tapered columns</li> <li>• Front door simply detailed with surrounds</li> </ul>
Windows	<ul style="list-style-type: none"> <li>• Simple, rectilinear window forms and patterns</li> <li>• Wood or stucco window trims on front elevation and other highly visible elevations</li> </ul>
Accents and Trims	<ul style="list-style-type: none"> <li>• Simple, rustic door and window trims</li> <li>• Stucco or simulated wood eave details</li> </ul>



## Americana - Traditional

The Traditional style evolved from the National style and continues to maintain the rectilinear massing with gable roof forms, with greater articulation in wall planes and variety in massing. Frontages are similar and include covered stoops or broad covered porches (with porches being more common). Exterior wall materials can include stucco, stone, brick, plank siding, or a combination of these. Details include simple columns or columns with brackets supporting the porch, corbels, additional trim details around windows and doors, and accent features.



## Americana - Traditional Design Elements

Form and Massing	<ul style="list-style-type: none"> <li>• Rectilinear form with vertical and horizontal massing breaks</li> </ul>
Roofs	<ul style="list-style-type: none"> <li>• Front to back gable or hip roof with intersecting hip or gable roofs</li> <li>• 6:12 to 12:12 primary roof pitch</li> <li>• 12" to 24" overhangs</li> <li>• Flat shingle-textured concrete tiles or architectural composition shingles</li> </ul>
Exterior Wall Materials	<ul style="list-style-type: none"> <li>• Blended stucco and siding, with brick and stone accents</li> </ul>
Entries	<ul style="list-style-type: none"> <li>• Simple stoop or covered porch</li> <li>• Simple square porch posts or tapered columns</li> <li>• Front door detailed with simple trim</li> </ul>
Windows	<ul style="list-style-type: none"> <li>• Simple, rectilinear window shapes</li> <li>• Windows often grouped in two or three</li> </ul>
Accents and Trims	<ul style="list-style-type: none"> <li>• White or off-white detailing trim</li> <li>• Decorative accent windows</li> </ul>



## Americana - Victorian

Popular in the second half of the 19th century, the Victorian style evolved from the National style and continues to maintain the rectilinear massing with gable roof forms with greater articulation in wall planes and variety in massing. Frontages are similar and include covered stoops or broad covered porches. Exterior wall materials can include plank siding, stucco, stone, brick, or a combination of these. Details include decorative posts with detailed brackets supporting the porch, spindle-work, decorative gable end detailing, and trim details around windows and doors.



## Americana - Victorian Design Elements

Form and Massing	<ul style="list-style-type: none"> <li>• Asymmetrical one and two story massing</li> </ul>
Roofs	<ul style="list-style-type: none"> <li>• Steeply pitched roofs of irregular shapes, usually with dominant front facing gable</li> <li>• 5:12 to 8:12 primary roof pitch</li> <li>• 12” to 24” overhangs</li> <li>• Flat concrete tiles or architectural composition shingles</li> </ul>
Exterior Wall Materials	<ul style="list-style-type: none"> <li>• Blended lap siding and stucco</li> <li>• Textured shingles</li> </ul>
Entries	<ul style="list-style-type: none"> <li>• Covered porches</li> </ul>
Windows	<ul style="list-style-type: none"> <li>• Rectilinear windows with divided lights</li> <li>• Windows often grouped in pairs</li> </ul>
Accents and Trims	<ul style="list-style-type: none"> <li>• Spindle-work, patterned masonry, and other classical design elements</li> <li>• Bay windows, patterned shingles, and other enhancements may be used to avoid smooth-walled appearance</li> <li>• Decorative porch posts with detailed brackets</li> <li>• Decorative gable end detailing; fascia at rafter tails</li> <li>• White or off-white window and door trims</li> </ul>



## Americana - Ranch

First built in the 1930s in California, the Ranch style became popular in the United States after World War II. The earliest Ranch style homes reflect a relaxed, casual western lifestyle. The typical Ranch home is a single-story building with a primary gable roof. This style is noted for its long, close-to-the-ground profile, and minimal use of exterior and interior decoration. Although Ranch style homes are traditionally one-story, Raised Ranch and Split-Level Ranch homes have several levels of living space. Contemporary Ranch style homes are often accented with details borrowed from Mediterranean or Colonial styles.



## Americana - Ranch Design Elements

Form and Massing	<ul style="list-style-type: none"> <li>• Informal, asymmetrical, horizontal building form</li> </ul>
Roofs	<ul style="list-style-type: none"> <li>• Predominately gable or shed roofs, or a blend of both; limited use of hip roofs</li> <li>• 4:12 to 6:12 primary roof pitch</li> <li>• 12” to 24” overhangs</li> <li>• Shake-textured flat concrete tiles or architectural composition shingles</li> </ul>
Exterior Wall Materials	<ul style="list-style-type: none"> <li>• Stucco with horizontal lap or board and batten siding elements</li> <li>• Brick or stone accents</li> </ul>
Entries	<ul style="list-style-type: none"> <li>• Covered porches with substantial width</li> </ul>
Windows	<ul style="list-style-type: none"> <li>• Rectilinear or square window shapes with divided lights</li> <li>• Grouped windows</li> </ul>
Accents and Trims	<ul style="list-style-type: none"> <li>• Simple, square wooden posts</li> <li>• Decorative porch railing</li> <li>• Closed eaves and fascias</li> <li>• Simple knee braces</li> <li>• Extended gable ridge over face of home</li> <li>• Window surrounds or shutters</li> </ul>

## Arts & Crafts - Craftsman

The Craftsman style dominated the first part of the 20th Century. Inspired by the American and English Arts and Crafts Movement that were popular during this time, the style focused on simplicity of form and the use of natural materials that blend with and complement the surrounding natural landscape. Typical features include horizontal massing; broad eaves with exposed rafter tails and brackets; multi-paned windows and doors; and wide porches with timber posts and heavy bases. Materials are varied and include stucco, plank siding, stone, shingle, and brick.



## Arts and Crafts - Craftsman Design Elements

Form and Massing	<ul style="list-style-type: none"> <li>• Simple one and two story massing with vertical and horizontal breaks</li> </ul>
Roofs	<ul style="list-style-type: none"> <li>• Front gable, cross gable or side gable roofs with broad overhangs</li> <li>• 4:12 to 5:12 primary roof pitch</li> <li>• 12” to 36” overhangs</li> <li>• Shingle-textured flat concrete ties or architectural composition shingles</li> </ul>
Exterior Wall Materials	<ul style="list-style-type: none"> <li>• Blended siding and stucco</li> <li>• Stone or brick accents</li> </ul>
Entries	<ul style="list-style-type: none"> <li>• Full or partial width porches, with square posts or tapered columns on solid stone or brick piers</li> </ul>
Windows	<ul style="list-style-type: none"> <li>• Vertically proportioned, upper mullioned double hung windows at front elevation and in high visibility areas</li> <li>• Windows often grouped in two or three</li> </ul>
Accents and Trims	<ul style="list-style-type: none"> <li>• Exposed rafter tails and beams or simple knee braces under deep eaves</li> <li>• Partially glass-paned front door</li> <li>• Window and door trim surrounds</li> <li>• Transom section sometimes above lower level windows</li> </ul>



## Arts & Crafts - Foursquare

The Foursquare style includes many of the same features of Craftsman and Prairie style homes. Also, inspired by the Arts and Crafts Movement, the style focused on simplicity of form and quality handcrafted workmanship. Massing is square and boxy, and typically one and two stories in height. Roofs are usually hipped with broad eaves and a front facing dormer. Additional dormers are sometimes provided on side and rear elevations. Large, raised porches supported by simple columns and heavy bases provide access to front doors. Materials include stucco and siding, with brick or stone accents.



## Arts and Crafts - Foursquare Design Elements

Form and Massing	<ul style="list-style-type: none"> <li>• One and two story massing, square and boxy form</li> </ul>
Roofs	<ul style="list-style-type: none"> <li>• Hip roofs with broad eaves and front-facing central dormers</li> <li>• 4:12 to 6:12 primary roof pitch</li> <li>• 12" to 24" overhangs</li> <li>• Shingle-textured flat concrete tiles or architectural composition shingles</li> </ul>
Exterior Wall Materials	<ul style="list-style-type: none"> <li>• Blended siding and stucco</li> <li>• Brick or stone accents</li> </ul>
Entries	<ul style="list-style-type: none"> <li>• Large, raised porches supported by simple columns and heavy bases</li> </ul>
Windows	<ul style="list-style-type: none"> <li>• Vertically proportioned windows with wood or stucco surrounds at front elevation and in high visibility areas</li> <li>• Dormer windows</li> </ul>
Accents and Details	<ul style="list-style-type: none"> <li>• Window and door surrounds</li> <li>• Exposed rafter tails and beams or simple knee braces under deep eaves</li> </ul>

## Arts & Crafts - Prairie

Also popular during the early 20th Century, the Prairie style of architecture is characterized by low-lying roofs and strong, horizontal lines. Prairie homes are commonly found in the Midwest and promoted by Frank Lloyd Wright as “organic architecture” that grew from the ground. Prairie homes are typically two stories tall, with single story elements and gently sloping hipped roof forms. Overhangs are broad and windows are repeated in linear, horizontal bands to enhance the horizontal massing of the building. Materials include stucco with stone or brick accents. Architectural detailing is used to convey craftsmanship.





## Arts and Crafts - Prairie Design Elements

Form and Massing	<ul style="list-style-type: none"> <li>• One or two story massing, with strong, horizontal form</li> </ul>
Roofs	<ul style="list-style-type: none"> <li>• Hip roofs</li> <li>• 3.5:12 to 5:12 primary roof pitch</li> <li>• 12" to 36" overhangs</li> <li>• Flat concrete tiles or architectural composition shingles</li> </ul>
Exterior Wall Materials	<ul style="list-style-type: none"> <li>• Blended siding and stucco</li> <li>• Brick and stone accents</li> </ul>
Entries	<ul style="list-style-type: none"> <li>• Covered entry</li> <li>• Stucco or wood columns on stone or brick bases</li> </ul>
Windows	<ul style="list-style-type: none"> <li>• Vertically proportioned windows grouped in horizontal bands</li> </ul>
Accents and Details	<ul style="list-style-type: none"> <li>• Contrasting wall materials or trim emphasizing horizontality</li> <li>• Boxed stucco soffits</li> <li>• Wide, square porch columns</li> </ul>



## Early California - Hacienda

The Hacienda style reflects California's Mexican heritage, when California was still under Mexican rule. Mexican haciendas reflect the landscape and temperate climate of Mexico and Southern California with a strong focus on indoor-outdoor relationships and passive cooling and heating. The Hacienda style is characterized by courtyards, covered arcades, tile roofs, and rich colors found in nature. Arched windows, doors, and porticos are also typical features of this architectural style. Homes typically have stucco exterior walls, with detailing that includes iron, tile, timber and stone.



## Early California - Hacienda Design Elements

Form and Massing	<ul style="list-style-type: none"> <li>• Two story massing with strong one story element</li> </ul>
Roofs	<ul style="list-style-type: none"> <li>• Simple hip or gable roof with intersecting gables</li> <li>• 4:12 to 5:12 primary roof pitch</li> <li>• 12” to 18” overhangs</li> <li>• Barrel or “S” shape concrete tiles</li> </ul>
Exterior Wall Materials	<ul style="list-style-type: none"> <li>• Stucco</li> </ul>
Entries	<ul style="list-style-type: none"> <li>• Arched stucco column porches</li> </ul>
Windows	<ul style="list-style-type: none"> <li>• Vertically proportioned, paned windows at front elevation and high visibility areas</li> <li>• Often grouped in two or three</li> <li>• Recessed or trimmed with header/sills or surrounds</li> </ul>
Accents and Trims	<ul style="list-style-type: none"> <li>• Stucco over foam window and door trims</li> <li>• White tone body with bright or dark brown accent trims</li> <li>• Stucco or simulated wood eave details</li> <li>• Metal, stone, timber, tile accents</li> <li>• Window shutters</li> </ul>

## Early California - Monterey

The Monterey style originated from California during the mid-1800s, while California was under Mexican rule. It fuses local Spanish/Mission influences with Colonial designs from the east coast. The massing of this style is generally box-like, with a simple front-to-back gable roof. The dominant feature of the Monterey style is the long, second story balcony that extends horizontally across the front of the home. Other elements of the Monterey architectural style include stucco wall materials with iron and wood details, window shutters and “S” tile roofs. Roof form is typically a gable end or cross gable roof.



## Early California - Monterey Design Elements

Form and Massing	<ul style="list-style-type: none"> <li>• Simple boxy plan form and two story massing</li> </ul>
Roofs	<ul style="list-style-type: none"> <li>• Predominantly front or front-to-back gable roofs; limited use of shed roofs</li> <li>• 4:12 to 6:12 primary roof pitch</li> <li>• 12” to 24” overhangs</li> <li>• Barrel or S” shape concrete tiles, flat concrete tiles or shake-textured concrete tiles</li> </ul>
Exterior Wall Materials	<ul style="list-style-type: none"> <li>• Stucco</li> <li>• Brick or siding accents</li> </ul>
Entries	<ul style="list-style-type: none"> <li>• Covered porches</li> </ul>
Windows	<ul style="list-style-type: none"> <li>• Square or rectilinear window shapes</li> </ul>
Accents and Trims	<ul style="list-style-type: none"> <li>• Simplified colonial style window and door trim</li> <li>• Projecting second story balcony with wooden posts and railing</li> <li>• Ornate chimney top trim</li> <li>• Rafter tails and beams</li> <li>• Window shutters</li> <li>• Metal railings</li> </ul>



## Mediterranean Countryside - Andalusian

Andalusian architecture was found throughout parts of Spain and Portugal and was influenced by the Moorish architecture that dominated this region between 711 and 1493. This style is characterized by rich features such as horseshoe arches and variety of other decorative arches, domes, intricate patterned screens and tiles, and courtyards. Massing forms are usually asymmetrical and horizontal with towers or vertical massing elements. Roofs are hipped but can include secondary gable roof forms.



## Mediterranean Countryside - Andalusian Design Elements

Form and Massing	<ul style="list-style-type: none"> <li>• Simple two or three story massing</li> </ul>
Roofs	<ul style="list-style-type: none"> <li>• Primary gable or hip roofs with secondary gable, hip or shed roofs</li> <li>• 4:12 to 6:12 primary roof pitch</li> <li>• 0” to 12” overhangs</li> <li>• Clay colored barrel or “S” shape concrete tiles</li> </ul>
Exterior Wall Materials	<ul style="list-style-type: none"> <li>• Stucco</li> <li>• Optional tile accents and/or brick on visible elevations</li> </ul>
Entries	<ul style="list-style-type: none"> <li>• Covered porches, recessed entry</li> </ul>
Windows	<ul style="list-style-type: none"> <li>• Primary recessed arch window on front elevation</li> <li>• Vertically proportioned windows</li> </ul>
Accents and Trims	<ul style="list-style-type: none"> <li>• Eaves include stucco details or wood corbeled rafter tails</li> <li>• Wrought iron elements such as decorative grille, awnings, or sculpted arches or walls</li> <li>• Spanish tile accents</li> <li>• Plank shutters</li> <li>• Pre-cast stucco wall ornamentation</li> </ul>

## Modern - Mid-Century Modern

The Mid-Century Modern style reflects the mid-20th century modernist movement in design, architecture, and urban development from approximately 1935 to 1975. This style was a further development of Frank Lloyd Wright's principles of organic architecture, combined with many elements reflected in the International movement. Function was as important as form. Simplicity and minimalist design approach worked together to create comfortable and elegant homes that connect people with nature. Large, expansive windows and open floor plans are key features of the Mid-Century Modern style, with the intention of opening up interior spaces and bringing the outdoors in. Many Mid-Century Modern houses utilized post and beam design to eliminate bulky support walls in favor of walls that appear to be made of mostly glass. Other key characteristics of this style included clean, geometric lines, varying depths in elevations, integration of natural materials, and pitched and/or flat roofs.



## Modern - Mid-Century Modern Design Elements

Form and Massing	<ul style="list-style-type: none"> <li>• Simple one, two or three-story massing</li> </ul>
Roofs	<ul style="list-style-type: none"> <li>• Low, overhanging pitched roof and/or flat roof</li> <li>• 3.5:12 to 5:12 primary roof pitch or flat</li> <li>• 0" to 24" overhangs</li> <li>• Architectural composition shingles or standing seam metal</li> </ul>
Exterior Wall Materials	<ul style="list-style-type: none"> <li>• Stucco, in combination with siding</li> <li>• Brick or stone accent</li> </ul>
Entries	<ul style="list-style-type: none"> <li>• Recessed entry</li> </ul>
Windows	<ul style="list-style-type: none"> <li>• Vertically proportioned windows</li> <li>• Large picture windows</li> </ul>
Accents and Trims	<ul style="list-style-type: none"> <li>• Natural accent materials such as wood, stone or brick</li> <li>• Bright, strong accent color on front door</li> <li>• Concrete block screen</li> <li>• Minimal façade ornamentation</li> </ul>



## Contemporary - Transitional

The Transitional style refers to an updated traditional style with a contemporary twist, incorporating features that are less ornate than traditional designs, but not as severely basic as modern styles. In addition to bridging traditional and modern aesthetics, Transitional style homes also could blend influences from various architectural styles to create a classic, clean and balanced look. This evolving style allows for adaptable and functional designs that incorporate sustainable and advanced technology features associated with modern living. Key characteristics of the Transitional style include clean-lined form and mass, simple, asymmetrical façades with multiple layers of texture and color, and minimal accents exhibiting a sense of simplicity and sophistication.



## Contemporary - Transitional Design Elements

Form and Massing	<ul style="list-style-type: none"> <li>• Simple one, two or three-story massing</li> <li>• Clean lines and geometric shapes</li> </ul>
Roofs	<ul style="list-style-type: none"> <li>• Flat and/or pitched roofs (gable, hip or shed)</li> <li>• 3.5:12 to 6:12 primary roof pitch or flat</li> <li>• 0" to 12" overhangs</li> <li>• Flat concrete tiles or architectural composition shingles; standing seam metal</li> </ul>
Exterior Wall Materials	<ul style="list-style-type: none"> <li>• Stucco, siding, brick, stone, metal, and architectural paneling systems</li> </ul>
Entries	<ul style="list-style-type: none"> <li>• Recessed entry</li> </ul>
Windows	<ul style="list-style-type: none"> <li>• Rectilinear or square window shapes</li> <li>• Large glass windows or corner windows</li> </ul>
Accents and Trims	<ul style="list-style-type: none"> <li>• Siding, stone or brick accent materials</li> <li>• Metal accents such as corrugated metal siding and metal railings</li> <li>• Horizontal awnings</li> <li>• Simple trims and details and multiple layers of textures and colors to enhance elevation</li> </ul>

## 6.2 Building Typologies

A variety of building typologies are described in this section to provide future builders with guidance regarding the types of buildings envisioned within the Specific Plan Area. *Table 6.1: Appropriate Building Typologies by Land Use*, indicates building typologies appropriate for each land use designation. An appropriate mix of building typologies should be incorporated into each Village to ensure diverse and interesting streetscenes. The Development Services Director may allow additional building typologies than those contained herein when they are consistent with the intent of the Specific Plan.

**Table 6.1: Appropriate Building Typologies by Land Use Designation**

Building Typology <sup>1</sup>	Village Land Use Designations					
	VC	LDR	MDR	AA	A	S
<b>Single Family Detached Homes</b>		X	X		X	
<ul style="list-style-type: none"> <li>• Conventional Homes</li> <li>• Rear Loaded Homes</li> <li>• Z-Lot Homes</li> </ul>						
<b>Detached Clusters Homes</b>	X	X	X	X	X	
<ul style="list-style-type: none"> <li>• Cottages</li> <li>• Green Court Homes</li> <li>• Motor Court Homes</li> </ul>						
<b>Attached/Semi-Detached Homes</b>	X		X	X	X	
<ul style="list-style-type: none"> <li>• Duplexes/Duets</li> <li>• Row Homes</li> <li>• Townhouse</li> <li>• Green Court Buildings</li> <li>• Motor Court Buildings</li> <li>• Stacked Units</li> <li>• Live/Work Buildings</li> </ul>						
<b>Attached Buildings</b>	X					
<ul style="list-style-type: none"> <li>• Wrap Buildings</li> <li>• Podium Buildings</li> <li>• Shopkeeper Buildings</li> <li>• Liner Buildings</li> </ul>						
<b>Community Buildings</b>	X	X	X	X	X	X

1. Additional building typologies that enhance diversity in streetscenes and housing types are permitted, provided that they are consistent with the intent of the Fanita Ranch Specific Plan, are compatible with the surrounding neighborhoods and meet the land use regulations contained in *Chapter 3* of the Specific Plan.



## 6.2.1 Single Family Detached Homes

Single family detached homes come in a wide range of sizes. Regardless of the size, these homes are all plotted on a single lot with front doors that take access directly from the street. There are three primary types of single family detached homes: Conventional, rear loaded and z-lot homes, as illustrated and described on the following page. Other types of single family detached homes are encouraged to provide diversity in housing types, provided they meet the development standards of the designated land use designations as well as the following standards:

### A. Plotting

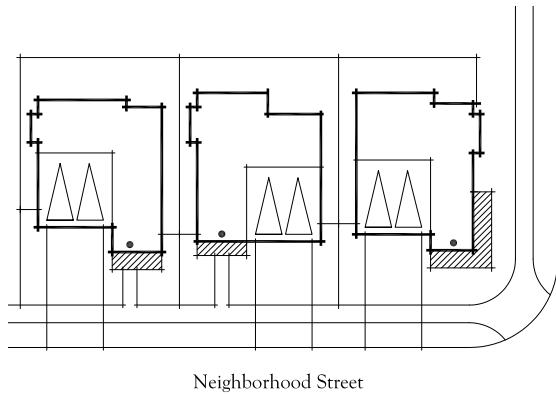
1. Front doors shall be covered and oriented toward a public or private street frontage.
2. At least one pedestrian feature shall be provided on each home. Pedestrian features include stoops, porches, courtyards, feature windows or similar design elements that enhance the streetscene and create pedestrian scale.
3. Porches shall have a minimum dimension of 6 feet in any direction.
4. Stoops shall have a minimum dimension of 42 inches in any direction.
5. Fences and walls within the front yard shall not exceed 3.5 feet in height.<sup>1</sup>
6. See *Chapter 3: Land Use & Development Regulations* of the Specific Plan for setbacks and development standards.

### B. Parking Placement

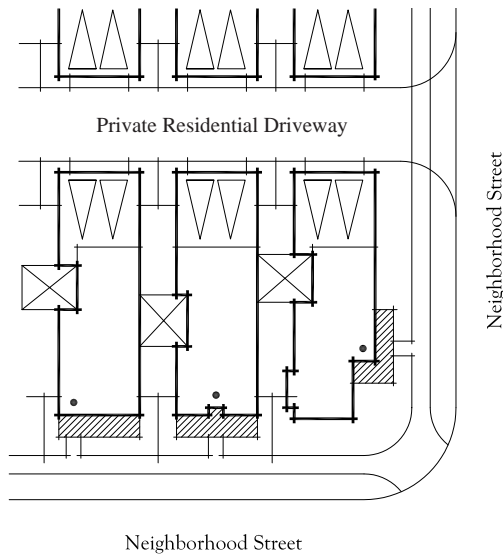
1. Garage access may be taken from the street or a rear private residential driveway. In flag lot conditions, garage access may be taken from a shared drive.
2. Garage driveways taking access from a public street shall provide a minimum depth of 18 feet, measured from the back of sidewalk to the face of the garage door.
3. Garages shall be setback a minimum of 5 feet from the porch or front living area.
4. Private residential driveways shall be a minimum of 20 feet in width, subject to review and approval of the Santee Fire Department. Driveway aprons adjacent to the private residential driveways shall be 5 feet in depth. Alternatively, full garage driveways with a minimum depth of 18 feet may be provided. The distance between garage doors across the private residential driveway shall be a minimum of 30 feet.
5. Private residential driveways shall be enhanced with landscaping, lighting and/or hardscape features.
6. See *Chapter 3: Land Use & Development Regulations* of the Specific Plan for parking requirements.

---

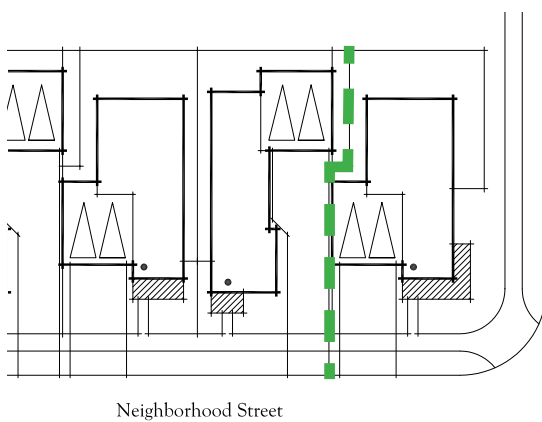
1. Retaining walls within the front setback shall not exceed 4 feet in height.



**Conventional Homes** are located on a variety of lot sizes and configurations. Access to front entries and garages are taken from the street.



**Rear Loaded Homes** are designed to take garage access from a shared private residential driveway behind the home. Private yard space is provide behind the house between a detached garage and the home, behind the house adjacent to the home, or in a side yard. Reciprocal use easements may be used to maximize side yard areas.



**Z-Lot Homes** are designed to fit together along a shared lot line by providing one home with a deeply recessed garage. Reciprocal use easements are provided to maximize side yard areas.

*Note: The above diagrams and photos are for illustrative purposes only. Actual plotting and floor plans may vary. Additional building typologies may be permitted as described in Section 6.2.*

## 6.2.2 Detached Cluster Homes

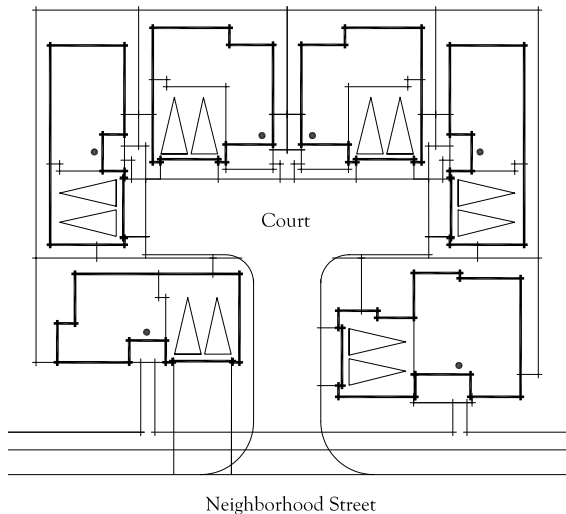
Detached cluster homes refer to a group of detached homes centered around a common feature such as a shared driveway or open space area. Detached cluster homes can be large or small in size, and are designed to provide a variety of alternatives to conventional single family homes. Depending upon the size and design, detached cluster homes can achieve the following:

- Offer single-family detached living opportunities at more attainable costs.
- Create smaller enclaves within the larger village setting creating opportunities for residents to share resources, spaces and engage as a community.
- Diversify the streetscene and the housing types within single-family neighborhoods.
- Improve the streetscene by removing garages from the street.
- Provide a small-lot single family home with a private yard area.

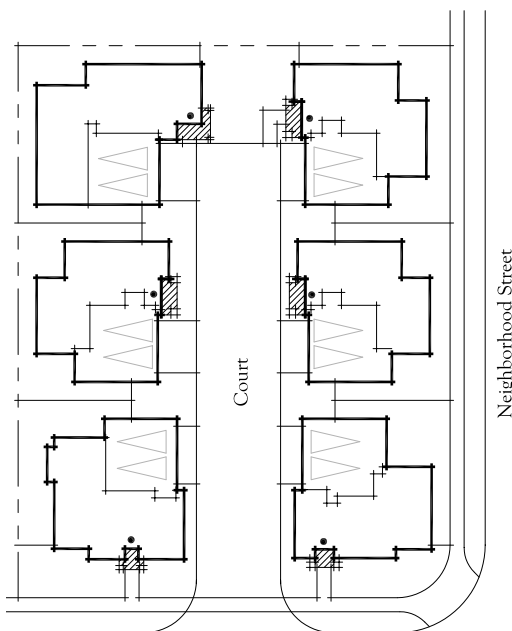
There are currently three primary types of detached cluster homes; however, new configurations are encouraged to provide diversity in lifestyle and housing type. The three primary types of detached cluster homes include cottages, green courts and motor courts. Depending upon their size and design, detached cluster homes can occur in either multi-family neighborhoods or single-family neighborhoods, provided they meet the development standards of the designated land use designations. All detached cluster homes shall also meet the following standards:

### A. Plotting

1. All setbacks not facing a public street shall be considered “interior side” setbacks, except when adjacent to the rear yard of a single family detached home. Where adjacent to the rear yard of a single family detached home, the minimum setback shall be the same as the required rear yard setback of the adjacent single family detached home to ensure privacy.
2. For homes fronting or siding on a public street, front door access shall be oriented to the public street and shall include at least one pedestrian feature such as a stoop, porch, feature window or similar design element that enhances the public streetscene and create pedestrian scale.
3. For homes fronting on a private residential driveway, front doors shall feature an architectural element designed to provide overhead cover or other elements designed to enhance and emphasize the front door.



Neighborhood Street



Neighborhood Street



**Motor Court Homes** are detached dwellings clustered around a motor court. The cluster group typically includes four to eight units. Primary entries face either the motor court or the street. Private outdoor living space can occur in side and/or rear yards. Automobile access is via private motor courts or streets. Resident parking spaces are provided in garages and guest parking is provided on local streets or designated on-site parking spaces. The motor court may be linear or “T-shaped.” Reciprocal use easements may be used to maximize side yard areas.

*Note: The above diagrams and photos are for illustrative purposes only. Actual plotting and floor plans may vary. Additional building typologies may be permitted as described in Section 6.2.*



4. Porches shall have a minimum dimension of 6 feet in any direction.
5. Stoops shall have a minimum dimension of 42 inches in any direction.
6. Fences and walls within the front yard of units facing the public street shall not exceed 3.5 feet in height.<sup>1</sup>
7. The minimum building separation for all detached cluster homes shall be 8 feet.
8. Detached cluster homes may use reciprocal use easements to maximize private yard areas.
9. See *Chapter 3: Land Use & Development Regulations* of the Specific Plan for setbacks and development standards.

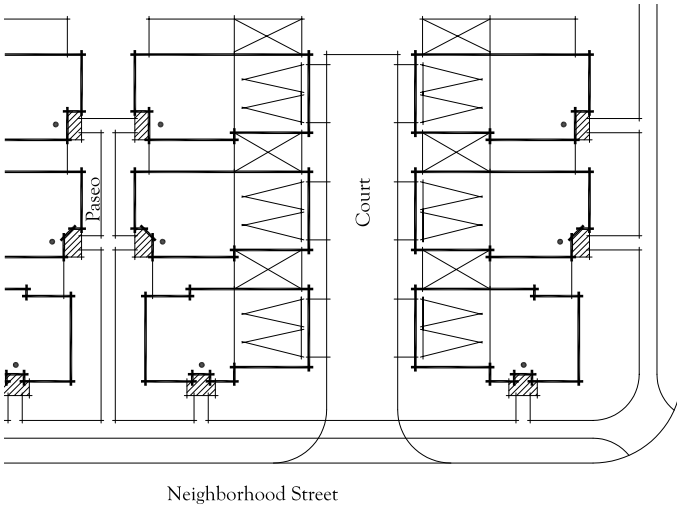
## **B. Parking Placement**

1. Garage access may be taken from the street, rear private residential driveway or motor court.
2. When garage access is taken from the street, a minimum driveway depth of 18 feet, measured from the back of sidewalk to the face of the garage door, shall be provided.
3. Private residential driveways and motor courts shall be a minimum of 20 feet in width, subject to review and approval of the City of Santee Fire Department. Driveway aprons adjacent to the private residential driveways and motor courts shall be 5 feet in depth. Alternatively, full garage driveways with a minimum depth of 18 feet may be provided. The distance between garage doors across the private residential driveway and motor court shall be a minimum of 30 feet.
4. Motor courts and private residential driveways shall be enhanced with landscaping, lighting and/or hardscape features.
5. See *Chapter 3: Land Use & Development Regulations* of the Specific Plan for parking requirements.

---

1. Retaining walls within the front setback shall not exceed 4 feet in height.

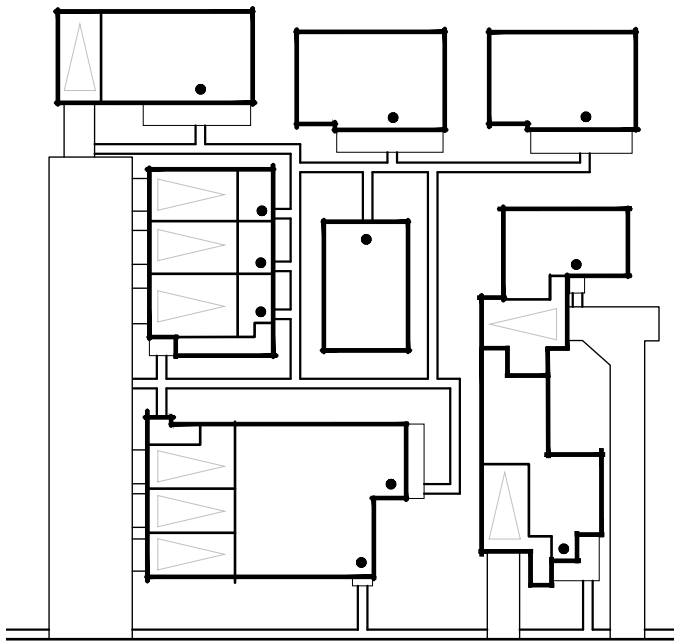
Detached Cluster Homes



Neighborhood Street



**Green Court Homes** are detached dwellings surrounding a green court or open space. Primary entries and walks face either the green court, open space or street. Reciprocal use easements may extend along private spaces on sides of buildings. Automobile access is via a private residential driveway or street. Resident parking spaces are provided in garages and guest parking is provided on local streets or designated on-site parking spaces. Green courts can be linear or square in configuration.



Neighborhood Street



**Cottages** are homes arranged around a common open space area. Front doors are accessed from the street or common walkways within the cluster. Some homes may have attached garages but most have detached garages that are grouped together and remotely accessed. Guest parking spaces are provided in common driveways or on local streets.

*Note: The above diagrams and photos are for illustrative purposes only. Actual plotting and floor plans may vary. Additional building typologies may be permitted as described in Section 6.2.*

### 6.2.3 Attached/Semi-Detached Homes

Attached or semi-detached homes refer to two or more homes that share a common wall or are separated by approximately 4 to 8 inches of air space with no shared common walls or foundations. There are a variety of possible configurations within this category of homes, ranging from duplexes to live/work buildings. Some examples are provided on the following pages, but new configurations of attached or semi-detached homes are encouraged to provide diversity and a variety of housing choices, provided that they meet the development standards of the designated land use designations.

#### A. Plotting

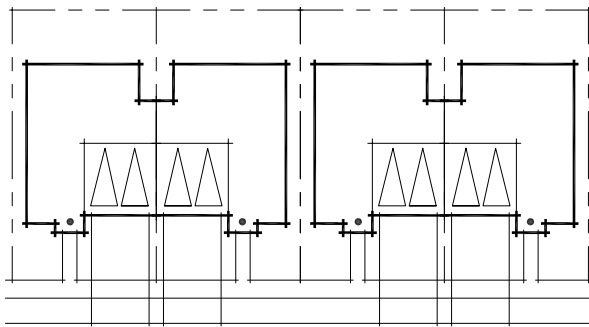
1. At least one pedestrian feature shall be provided on each home. Pedestrian features include stoops, porches, patios, courtyards, feature windows or similar design elements that enhance the public street scene and create pedestrian scale.
2. Porches shall have a minimum dimension of 6 feet in any direction.
3. Stoops shall have a minimum dimension of 42 inches in any direction.
4. Fences and walls within the front yard shall not exceed 3.5 feet in height.<sup>1</sup>
5. See *Chapter 3: Land Use & Development Regulations* of the Specific Plan for setbacks and development standards.

#### B. Parking Placement

1. Garage access may be taken from the street, a rear private residential driveway or a motor court.
2. Driveways taking access from a public street shall provide a minimum depth of 18 feet, measured from the back of sidewalk to the face of the garage door.
3. Private residential driveways and motor courts shall be a minimum of 20 feet in width, subject to review and approval of the City of Santee Fire Department. Driveway aprons adjacent to the private residential driveways and motor courts shall be 5 feet in depth. Alternatively, full garage driveways with a minimum depth of 18 feet may be provided. The distance between garage doors across the private residential driveway and motor court shall be a minimum of 30 feet.
4. Private residential driveways and motor courts shall be enhanced with landscaping, lighting and/or hardscape features.
5. See *Chapter 3: Land Use & Development Regulations* of the Specific Plan for parking requirements.

---

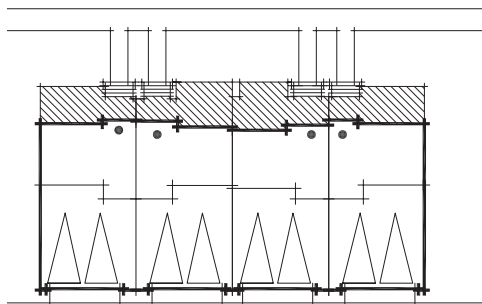
1. Retaining walls within the front setback shall not exceed 4 feet in height.



Neighborhood Street



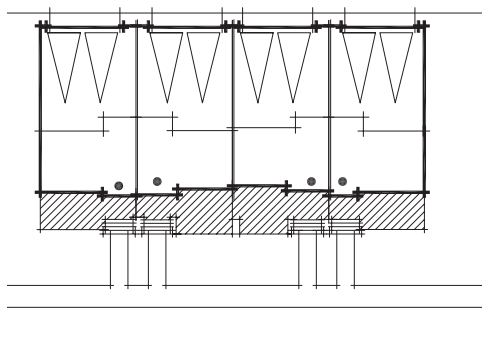
**Duplexes or Duets** are two individual dwelling units that may be attached (condominiums) on the same lot or detached by minimum 6 inches of air space (fee simple) on individual lots. Primary entries face the street. Private open space is provided in yards, patios, courtyards or upper floor balconies.



Private Residential Driveway



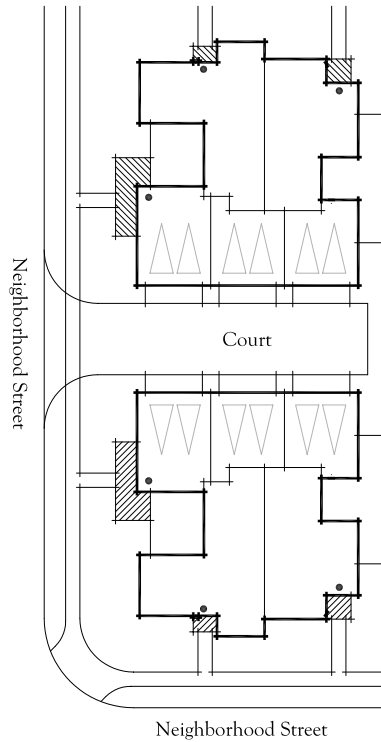
**Row Homes** are homes on individual lots that are aligned in a row and are separated by minimum 6 inches of air space (fee simple) along a common property line. Garage access is typically provided via a rear private residential driveway but can be provided directly from the street as well. Primary entries face the street or a common paseo. Private open space is provided in patios, courtyard or upper floor balconies.



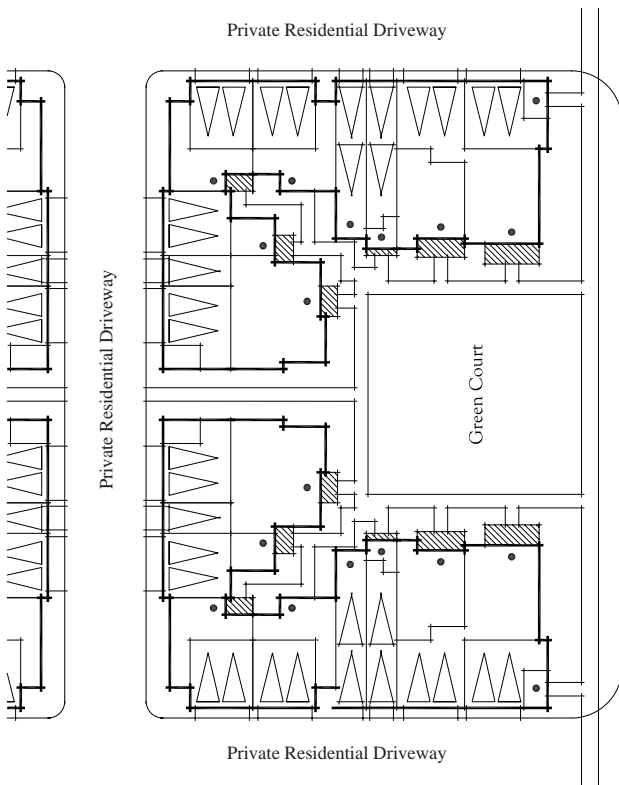
Neighborhood Street

*Note: The above diagrams and photos are for illustrative purposes only. Actual plotting and floor plans may vary. Additional building typologies may be permitted as described in Section 6.2.*



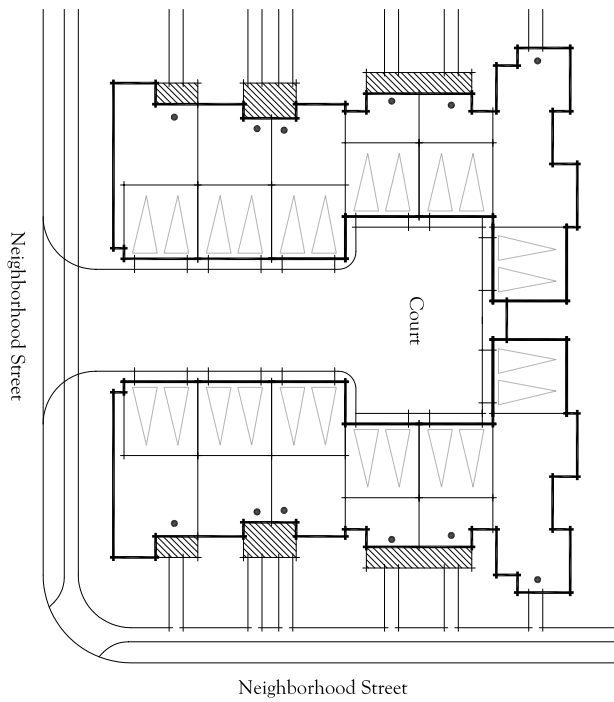


**Town Houses** are a collection of attached (condominium) single family homes. Garage access is typically provided via a rear private residential driveway or shared driveway. Primary entries face the street or a common paseo. Private open space is provided in patios, courtyard or upper floor balconies.

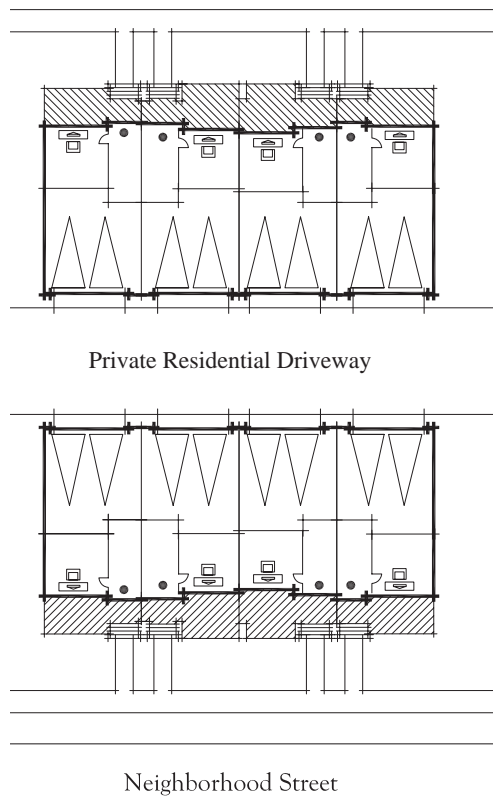


**Green Court Buildings** are organized around a green court open space or paseos. Front doors face the street, a green court or a paseo, and garage access is from a private residential driveway in the rear or side. The units have private outdoor living space in the form of patios or balconies. Resident parking spaces are provided in garages, and guest parking spaces are provided on local streets or in designated parking areas.

*Note: The above diagrams and photos are for illustrative purposes only. Actual plotting and floor plans may vary. Additional building typologies may be permitted as described in Section 6.2.*

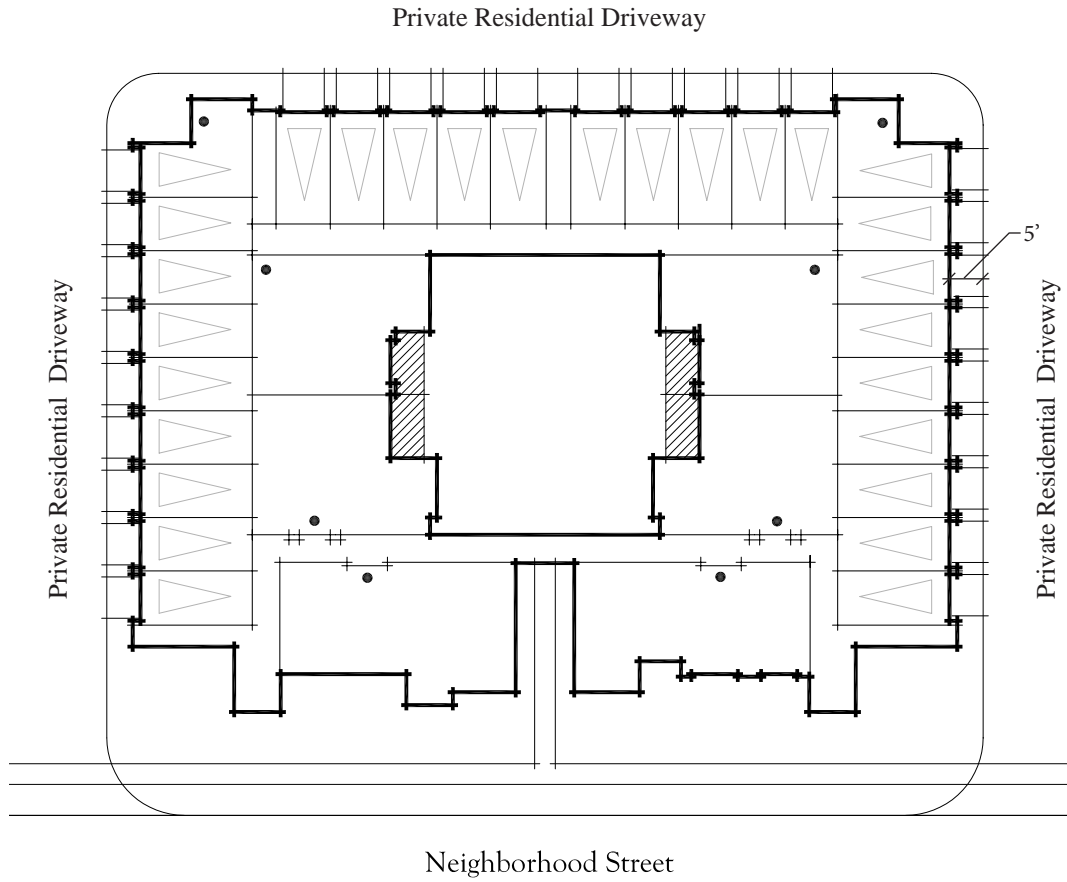


**Motor Court Buildings** are organized around a motor court. Garages are accessed from the motor court, and front doors are accessed from the street or a paseo. Each unit has a private outdoor living space in the form of a patio or balcony. Resident parking spaces are provided in garages, and guest parking spaces are provided on local streets or in designated parking areas.



**Live/Work Buildings** are residential homes with a dedicated work space. The work space is designed to provide spatial, but not necessarily physical, separation and visitors, between the living area and the work space so that clients visiting the work space do not need to enter the living area.

*Note: The above diagrams and photos are for illustrative purposes only. Actual plotting and floor plans may vary. Additional building typologies may be permitted as described in Section 6.2.*



**Stacked Units** are attached multifamily homes with entries accessed from interior hallways or courtyards. Automobile access is via a private residential driveway. Resident parking spaces are provided in individual garages or designated on-site parking spaces, and guest parking spaces are provided on local streets or in designated parking areas.

*Note: The above diagram and photos are for illustrative purposes only. Actual plotting and floor plans may vary. Additional building typologies may be permitted as described in Section 6.2.*

## 6.2.4 Attached Buildings

Attached buildings refers to large buildings that can contain multiple residential units, offices, and/or one or more commercial units. These buildings can be single use or mixed-use and are generally only found in the Village Centers and Medium Density Residential neighborhoods.

### A. Plotting

1. Primary building entries shall be oriented toward a public street frontage.
2. At least one pedestrian feature shall be provided on each Building. Pedestrian features include stoops, arcades, porticoes, courtyards, feature windows or similar design elements that enhance the public street scene and create pedestrian scale.
3. Stoops shall have a minimum dimension of 42 inches in any direction.
4. Courtyard walls within the front yards shall not exceed 3.5 feet in height.
5. See *Chapter 3: Land Use & Development Regulations* of the Specific Plan for setbacks and development standards.

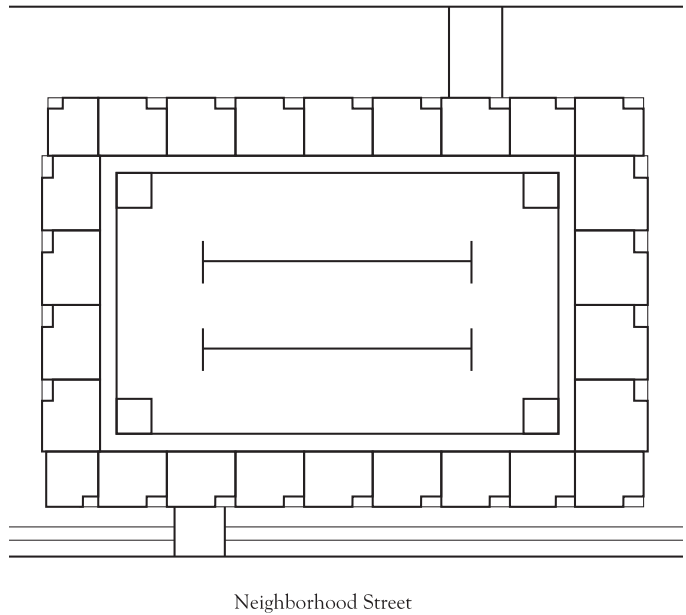
### B. Parking Placement

1. Garage access may be taken from the street or a rear private residential driveway.
2. Private residential driveways shall be a minimum of 20 feet in width, subject to review and approval of the Santee Fire Department. Driveway aprons adjacent to the private residential driveways shall be 5 feet in depth. The distance between garage doors across the private residential driveway shall be a minimum of 30 feet.
3. Private residential driveways shall be enhanced with landscaping, lighting and/or hardscape features.
4. See *Chapter 3: Land Use & Development Regulations* of the Specific Plan for parking requirements.

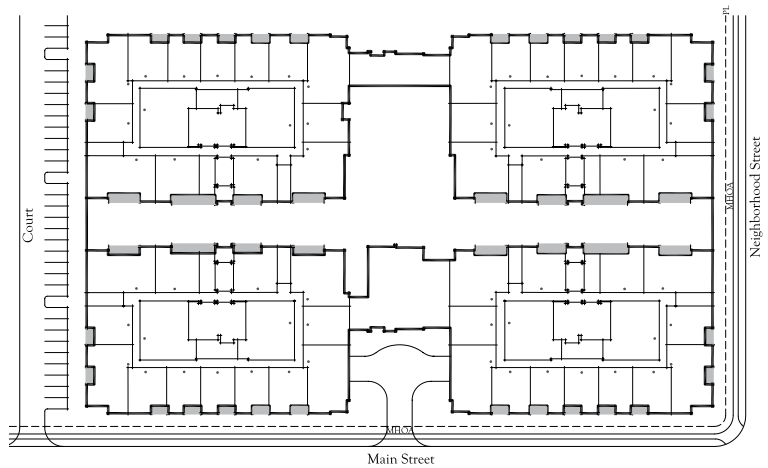


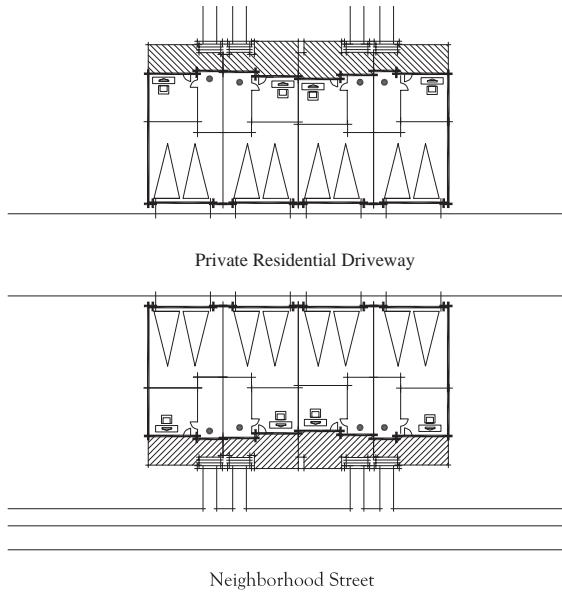


**Wrap Buildings** are multi-story buildings that wrap around structured parking. Buildings face the street and individual units are typically accessed from internal corridors. The parking structure is typically accessed via one or two access points that connect to a street or private residential driveway. Wrap buildings are typically commercial, high-density residential or mixed-use.

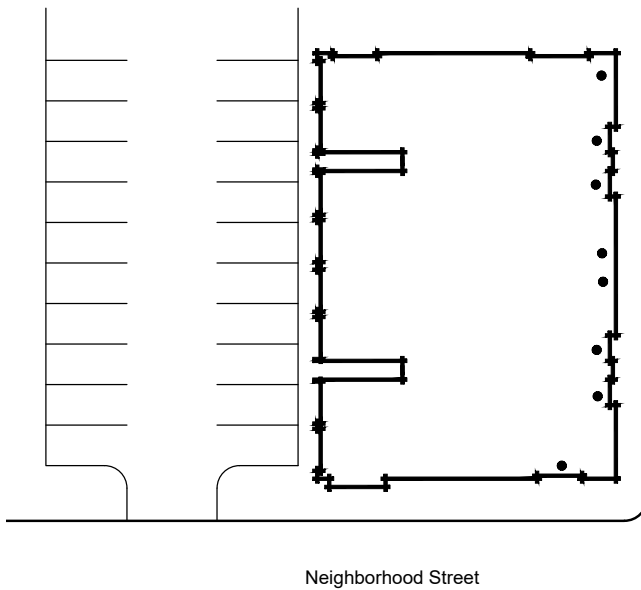


**Podium Buildings** are multi-story buildings that sit on top of structured parking. Buildings face the street and individual units are typically accessed from internal corridors. The parking structure is typically accessed via one or two access points that connect to the street or side street. Podium buildings are typically commercial, high-density residential or mixed-use.





**Shopkeeper Buildings** are mixed use buildings with work space and living area and a dedicated work space located within the same building. Unlike live/work buildings, the shopkeeper building is designed to provide separate entrances to the work space and the living area. If an interior connection is provided between both spaces, it is physically separated by a lockable door. This allows the work space to function independently of the residential unit so that it can be used by either the residential occupant of the unit or separate residential and retail occupants.



**Liner Buildings** are horizontal buildings that line the street with building entries facing the public sidewalk. Parking is located in a parking lot behind the building.

## 6.2.5 Community Buildings

Community buildings include buildings that serve as landmarks. These are typically civic or other community serving buildings such as schools, fire stations, churches or other religious or spiritual facilities, assembly halls, event barns and similar that serve a community purpose. Community buildings shall be designed in an Americana style of architecture to support the community design theme.



### A. Plotting

1. Visual prominence from streets and public spaces shall be the primary consideration when determining the location and design of community buildings. Massing elements should be used to create focal points at significant corners and view terminus.
2. Pedestrian scale and access should also be considered when locating and designing community buildings. Primary pedestrian entries shall be oriented toward a public street frontage or other public space, and should be a main feature of the elevation.
3. See *Chapter 3: Land Use & Development Regulations* of the Specific Plan for setbacks and development standards.



*Examples of community buildings, including a clubhouse and a farm activity center.*

### B. Parking Placement

1. Depending upon the use, parking may occur in parking lots or parking structures.
2. To minimize the visual impact of parking on the public street, parking lots and parking structures shall be located behind or to the side of the building so that they are not adjacent to the street.
3. Parking lots and parking structure access drives shall be enhanced with landscaping, lighting and/or hardscape features in accordance with the landscape.
4. See *Chapter 3: Land Use & Development Regulations* of the Specific Plan for parking requirements.

## 6.3 Building Design

The intent of the following building design guidelines is to ensure the creation of a high quality and pedestrian friendly community, with diverse neighborhoods and a cohesive sense of place. Not only do these guidelines ensure a high level of quality in function and visual appearance, but they also encourage architectural character that creates variety and compatibility, thus enhancing the community's overall appeal and value. Sustainable design practices are encouraged, and some strategies that would benefit the community include simple massing forms and efficient framing techniques, use of rapidly renewable resources, and installation of durable material that require less frequent replacement. Universal design in housing is also encouraged to create accessible spaces that serve the needs of people with disability and the aging seniors, particularly in the Active Adult neighborhoods. Additionally, "Crime Prevention through Environmental Design" (CPTED) elements should be incorporated into building and site design to facilitate natural surveillance, access control, territorial reinforcement and proper common area maintenance.

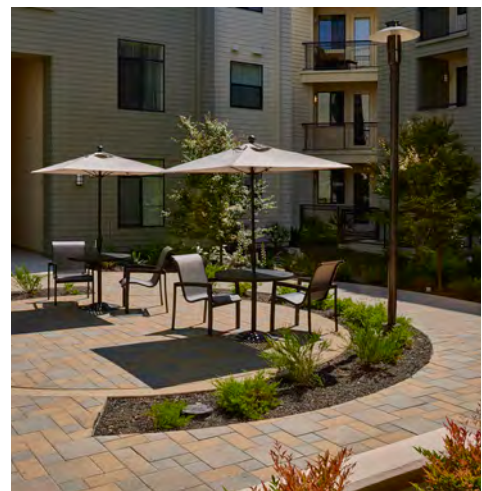
Fanita Ranch is located in a Wildland Urban Interface area. As such, planning, design and construction of all buildings within the Specific Plan Area shall comply with applicable regulations and standards set forth in SMC (as may be amended from time to time), California Building Code Chapter 7A and Fanita Ranch Fire Protection Plan.

### 6.3.1 Building Placement and Orientation

1. Orient buildings to face and frame the street to create a pedestrian friendly streetscape, as appropriate to the building typology.
2. Careful consideration should be given to building placement and street orientation to help protect privacy, views and the visual quality of the neighborhood.
3. Single-family residential lots and setbacks should incorporate variety in the design, orientation and placement of buildings, wherever practical.
4. Plot buildings to emphasize diversity and scale along the street and avoid visual monotony. Interest can be achieved by varying front setbacks, using different plan forms and elevations on adjacent buildings, incorporating single-story elements and utilizing different garage placements.
5. A sense of undulation in building setbacks can be achieved by incorporating significant massing offsets within the building footprint to create varied setbacks to different parts of the building, or by encouraging staggered front and/or rear setbacks on adjacent homes.



6. Where feasible, side setbacks should be varied to create greater solar access, provide more useful private open space and avoid a monotonous pattern of houses.
7. Buildings should be sited to respect the features of the natural environment, maximize view opportunities and solar access, where feasible and reasonable.
8. Building primary entries should be clearly visible to pedestrian and vehicular approaches.
9. Where feasible, arrange groups of attached residential buildings in clusters around outdoor spaces such as plazas, courtyards, pathways and other gathering spaces and connections that encourage social activity and promote pedestrian connectivity.
10. In general, commercial and mixed-use buildings should front onto a street or spine, which may be designed either as a vehicle free zone or in such a manner as to allow for use by both pedestrians and vehicles. Where vehicles are allowed, design features should be incorporated to define pedestrian movement through changes in paving materials or grade, articulated walks with landscaping, or overhead structures.
11. In the Village Centers, building fronts should generally be arranged to the property line with zero front setback to create a continuous street wall that provides scale and definition to adjacent streets and public spaces, except where recesses are provided for entries or widened sidewalks for outdoor dining, displays, etc.
12. Large, monolithic buildings, such as movie theaters, may be set back from the street and lined with smaller businesses in the front to create a more appealing streetscene.



13. Place buildings in such a way that they screen parking areas and minimize the impact of parking lots and garages on the public streetscape.

### 6.3.2 Form and Massing

1. Create simple floor plans that can be built efficiently and achieve high performance by starting with simple, rectilinear forms and massing that reflect the selected architectural style, then adding smaller, secondary massing elements to provide massing relief and break up the primary forms.
2. When feasible, design floor plans on a 2-foot module to allow for efficient framing, thereby reducing the amount of wood and waste.
3. Incorporate variety in product types and building forms appropriate to the architectural styles to enhance diversity and visual interest within the residential neighborhoods.
4. Vary setbacks from the street to massing elements to create movement and diversity in the front setback.
5. The building mass of larger buildings should be broken down into smaller elements to provide articulation and human scale to the streetscene.
6. Where appropriate, design the front elevation to clearly delineate individual units as a way of breaking up mass.
7. Taller buildings should have increased setbacks where feasible, so as not to dominate the streetscene and impose on surrounding uses and neighborhood character.



8. Avoid long, massive attached residential, commercial and mixed-use buildings by limiting individual building lengths. This is achieved by breaking buildings up into a collection of smaller, related buildings with paseos, courtyards, or similar spaces in between.
9. Where attached residential, commercial and mixed-use buildings are located adjacent to detached residential buildings, minimize impacts on adjoining residences with a sensitive transition in scale, massing and height, and design the transition to ensure resident privacy.
10. Consider stepping down corners and ends of large attached residential buildings in scale or incorporate articulations such as recessed balconies and enhanced window treatments at highly visible locations to soften the building edges and enhance the streetscene.
11. Commercial and mixed-use corner buildings may be designed as anchor buildings. Anchor buildings are often larger in scale and massing than surrounding buildings and may have more ornamentation than adjacent buildings. In addition, anchor buildings typically have both primary and secondary façade that relate to the streets on which they front.
12. Iconic buildings in the Fanita Commons Village Center are encouraged, which may include architectural features such as bell tower or similar statements appropriate to the architectural style of the building.

### 6.3.3 Garage Placement and Parking Areas

1. Incorporate a variety of garage placement configurations in the detached residential neighborhoods, including, but not limited to, front-loaded deep-, mid- and narrow-recessed garages, side-on garages, split garages, tandem garages and rear-loaded garages. Garages should generally be set behind the front face of the building, or be oriented to the private residential driveways or motor courts.
2. Surface parking lots or carports should be located to minimize visual impact.



3. Parking area access and internal circulation shall promote safety, efficiency and convenience, avoid conflicts between vehicles and pedestrians, and provide adequate areas for maneuvering, stacking and accommodating emergency vehicles.
4. Attached residential development entry areas should be enhanced with landscaped medians, enriched paving, decorative landscaped entry walls and gateway structures, etc.
5. In attached residential development, parking on main circulation drives or in large, undivided parking lots should be avoided where feasible. When parking cannot be incorporated within residential structures, smaller parking areas dispersed throughout the residential development site are preferred.
6. Locate parking spaces close to the residential units which they serve. Convenient, unobstructed and clearly identified pedestrian access that minimizes the need to cross circulation drives, parking aisles and landscaped areas should be provided to building entries.
7. Parking areas visible from the street or other areas exposed to public view should be screened by landscaping, earth berms, low screen walls or a combination thereof.
8. Install landscape planters and canopy trees in parking areas to add visual interest, soften the appearance of unrelieved paving and provide shade.
9. Carports may be provided in the interior parking areas of an attached residential development site. The placement of carports adjacent to streets, elevated slopes or other highly exposed areas is strongly discouraged. When provided, carports should be designed as an integral part of the residential development and be similar or complementary in materials and colors to the surrounding principal buildings.
10. Parking spaces designated for non-residential and residential uses in a mixed-use property should be clearly identified with sign posting, pavement markings and/or physical separation.

### **6.3.4 Roof Considerations**

1. Select roof forms, pitches and materials that support the architectural style of the building.
2. Consider roof forms in relationship to building mass to reduce and improve massing relief along public streets and on other publicly visible elevations.
3. Varied roof forms, offsets and materials consistent with the architectural style of the building are encouraged to create variation in the skyline and diversity in the streetscene. Flat roofs with



parapets or decorative cornices are permitted where appropriate to the architectural style of the building.

4. Terraces and rooftop open space are encouraged, particularly in buildings where residential uses are located above retail.
5. Keep roof forms simple and efficient to minimize lumber and material waste.
6. Roof materials should be of a matte finish to minimize glare and be durable to extend the life span of the roof and reduce landfill waste.
7. Roof eaves and roofing materials shall be consistent with the requirements of the Fanita Ranch FPP.
8. Design roofs to consist of low albedo materials or cool roof technologies to reduce heat island effect and maximize building energy efficiency.
9. Consider the location of the photovoltaic and solar panels and/or tiles, as well as any solar water heating panels, when designing roof plans.
10. Rooftop solar panels should be equipped with wire mesh screens to prevent bird or pest entry beneath the solar panels.
11. With the exception of photovoltaic and solar water heating panels, design roofs to screen any rooftop equipment from public view.
12. Roof-mounted and ground-mounted mechanical equipment shall be screened from view of streets, paseos and other public spaces. Devices such as exhaust fans, vents and pipes shall be painted to match the colors of the surfaces to which they are attached.



### 6.3.5 Articulation and Details

1. Building façades should be designed to provide an interesting connection between the public area, street and sidewalk, and private residence. Appropriate articulation and detailing include the following:
  - a. Variation in architectural styles
  - b. Undulating building mass and roof planes
  - c. Vertical and horizontal stepped massing
  - d. Visually reduced garages
  - e. Authentic architectural elements
  - f. Detailed entry features and openings such as doors, windows, porches, balconies, patios, courtyards and trellises oriented toward the street
2. Select architectural details that are proportional, complementary and authentic to the overall design of the elevation style.
3. On corner lot buildings, consider wrapping pedestrian elements such as porches and arcades around the corners to provide human scale along both street frontages.
4. Corner buildings and upper floor rear elevations that are visible from public streets, parks and other public spaces should incorporate single-story massing at the exterior side, wrapped porches or additional articulation along the exterior elevations such as window trims, pop-outs, insets or other vertical or horizontal breaks in the wall massing.
5. Building façades along the rear private residential driveways or motor courts should incorporate articulation such as massing offsets, projections, window recess, etc. to enhance the appearance of the private residential driveways and motor courts.



6. Windows and entries add articulation, break up massing and play a key role in defining the style of a building. They also contribute to the energy performance and thermal comfort of a home. Window and entry guidelines include the following:
- a. Coordinate window shape, size and location on each elevation to provide a logical, proportional and attractive composition consistent with the architectural style.
  - b. Recess windows to provide depth and create shadow, add articulation to each elevation and create visual interest, as appropriate to the architectural style.
  - c. Locate and size windows to respond to the conditions of the site including solar exposure.
  - d. Select energy efficient windows to improve building performance.
  - e. Install operable windows to improve interior thermal comfort and allow occupants to passively regulate indoor temperatures and air quality.
  - f. Locate windows and doors at regular 16” or 24” stud positions, when possible and without compromising design integrity, to minimize wasted lumber.
  - g. When feasible, design windows on south-facing elevations to provide passive solar heating and cooling. Consider adding shading devices, shade trees or special window designs that are consistent with the style of the building.
  - h. Front doors and entryways should provide the focal point on the public street elevation of a building and be protected from the sun with overhangs, recesses, porches or trellises consistent with the architectural style of the building.





7. Design lighting to minimize impact to adjacent properties, particularly open space areas, through careful placement and fixture selection. Lighting shall be shielded to minimize illumination of adjacent properties and reduce glare.
8. Vary wall planes to create depth and shadow and avoid continuous, unrelieved walls surfaces along publicly visible elevations. Building walls facing a public street or public space should not extend more than 30 feet vertically or horizontally without a visual break. Visual breaks can be created by an offset in the exterior wall plane, a recessed window or door or other architectural detailing.
9. Incorporate pedestrian entry elements such as stoops, patios, porches, arcades, etc. that are consistent with the style of the building and intended neighborhood character.
10. For commercial and mixed-use buildings, distinguish the first floor from upper floors through floor height, elevation design and application of materials to create a human scale.
11. Commercial and mixed-use buildings should incorporate pedestrian scaled details that add texture and visual interest along the sidewalk. These can include special building or landscape materials, additional glazing and/or design elements such as display windows, awnings, signage, shade structure, balconies, arcades and/or lighting specifically designed to enhance the pedestrian experience.
12. Entry area walls of commercial and mixed-use buildings should incorporate accent colors, higher level of detailing, and entry/accent lighting to provide a sense of welcome and convenient access into the building interior.
13. Facilitate open views into the retail space at the storefront level to enhance the pedestrian experience by providing a visual connection to the use inside the building.
14. Buildings with retail and restaurant uses are encouraged to have covered pedestrian arcades with a minimum depth of 8 feet parallel to the street.





15. Choose lighting locations for maximum visual enhancement and safety, highlight important features and provide lighting where people need it most. Attached residential complexes shall be lighted sufficiently to deter criminal activity.

### **6.3.6 Materials and Colors**

1. Materials and colors should be earth tones or muted colors complementary to the chosen architectural style and compatible with the character of surrounding development. Reserve bright or dark colors for trim or accents only.
2. Provide a variety in texture and color to allow for diversified expressions of individuality on building elevations, while maintaining visual cohesiveness throughout the community.
3. Apply colors and materials to enhance changes in wall plane, reinforce articulation of elevations, and enhance special features such as entries, single-story elements, etc.
4. Materials should be consistently applied and work harmoniously with adjacent materials. Avoid piecemeal embellishments and frequent changes in materials.
5. Ensure that materials and color blocking terminate at inside corner or is otherwise wrapped to avoid the appearance of false façades.
6. Select high-quality, low-maintenance and durable materials to minimize the need for replacement that would contribute to landfill waste.
7. Consider the use of recycled and or rapidly renewable materials, as well as pre-finished building materials to reduce waste and conserve resources.
8. Consider using low-VOC emitting building materials for flooring, carpet, adhesives, caulks, insulations, etc. to protect air quality.

### **6.3.7 Functional Elements**

1. Work with utility service providers to reduce visual clutter, eliminate location conflict of utility items in the common areas and address community aesthetics. Techniques to be considered include under-grounding where possible, landscape screening, construction of a façade and use of neutral or complementary colors.
2. Gas and electrical meters should be placed in utility cabinets or otherwise screened to be integral with the architecture of the building.

3. Roof-mounted and ground-mounted mechanical equipment such as air conditioning/heating equipment, pool/spa equipment, etc. (excluding solar panels) should be screened from view of public streets, parks and other public spaces.
4. Mechanical devices such as exhaust fans, vents and pipes should be painted to match the colors of the surfaces to which they are attached.
5. Exposed gutters and downspouts should be colored to match or complement the surface to which they are attached.

### **6.3.8 Loading, Service and Trash Storage Areas**

1. Loading/unloading and service areas should occur in the rear or on the side of the buildings away from public streets and activity areas where possible or be screened with landscaping, fences or walls. Fences and walls that provide screening should be designed as an integral part of the building design concept and constructed of materials, textures and colors which are complementary to the adjacent buildings.
2. Where a commercial development is located adjacent to a residential development, the loading and service areas should be located away from the residential buildings where possible or be screened with landscaping. Siting of the loading and service areas should consider potential noise and visual impacts to the adjacent development.
3. Loading and service areas should be designed to ensure vehicles have clearly identified and convenient access and do not block adjacent vehicular or pedestrian circulation.
4. Mixed-use development may utilize shared loading/delivery areas and on-street parallel parking as loading/delivery spaces. On-street loading/delivery spaces, where used, shall have loading signage posted adjacent to the space and be in addition to the required parking spaces for the mixed-use building residents/tenants.
5. Consider designating pickup/drop-off zones for ride-sharing services at appropriate locations in Village Centers. Passenger loading signage should be posted adjacent to the zone.
6. When trash and recycling material containers are provided to individual dwelling units, adequate space should be provided in a side or rear yard or in the interior of the garage to accommodate a minimum of two collection containers.
7. When trash and recycling material collection facilities are shared by a group of dwelling units and/or buildings, designated collection areas should be provided. These collection areas should be sited

for adequate, convenient and safe access and avoid impacting important neighborhood features such as entries, recreation areas, clubhouses and leasing offices. Trash and recycling enclosures should not be located along frontage streets within required front or street side setback areas.

8. Trash and recycling material collection facilities should be screened by architectural enclosures. The screening enclosure materials and colors should be similar or complementary to the exterior materials and colors used on the adjacent buildings.

# Chapter 7:

## Parks, Recreation & Open Space

### 7.1 Parks, Recreation and Open Space Objectives

*Exhibit 7.1: Conceptual Park, Recreation & Open Space Plan* illustrates the parks and recreational facilities proposed for Fanita Ranch. This chapter is closely related to the trails described in *Chapter 4: Mobility*. Parks, trails, and recreational facilities play a key role in supporting the vision for Fanita Ranch as a healthy, active community by offering opportunities to exercise and interact with family and the community. The Fanita Ranch Conceptual Park and Recreation Plan seeks to achieve the following:

- Provide a coordinated system of parks and recreational facilities that meet the recreational needs of Fanita Ranch and Santee residents and provide opportunities to enjoy the scenic qualities of Fanita Ranch.
- Use parks as a defining element for Villages and neighborhoods.
- Use parks as primary trail heads for community trails and connections to existing primitive and regional trails.
- Promote a cohesive, pedestrian friendly community that encourages non-vehicular trips and interaction between residents.
- Provide recreational facilities to support a wide variety of leisure activities including active/organized recreation, nature learning, informal play, creative play, relaxation, performances, social activities and service programs.
- Use the AgMeander as both a learning experience and recreational amenity for residents.
- Utilize crime prevention through environmental design principles to provide safe and secure park and recreation facilities.



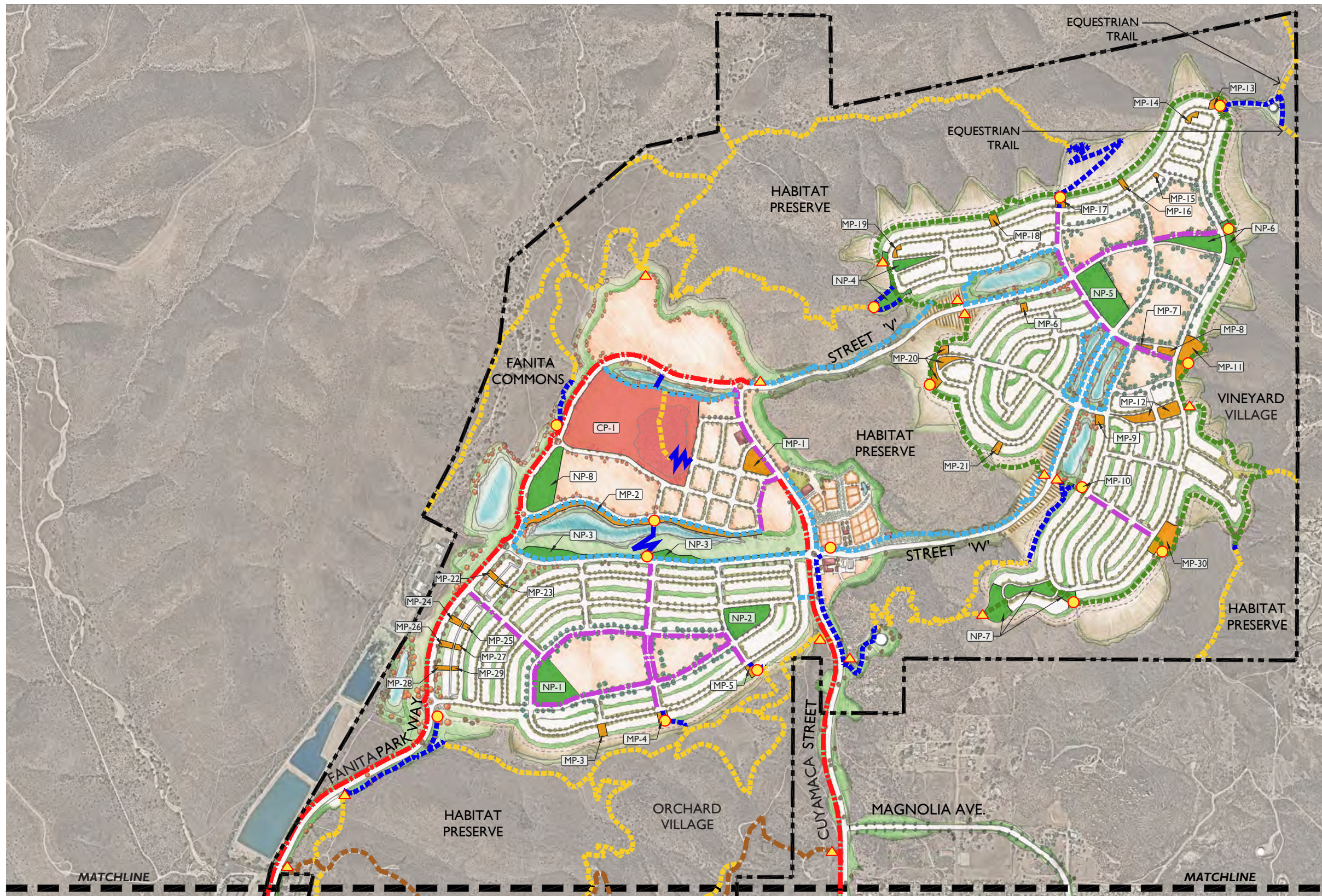
## 7.2 Park Land Dedication

Santee Municipal Code (SMC) Chapter 12.40, Park Lands Dedication establishes the provisions for dedication of land, payment of in-lieu fee or a combination of both for the purpose of providing park and recreation facilities to serve future residents of a subdivision development. SMC Section 12.40.070 requires the amount of land to be dedicated based on the average occupancy rate per dwelling type and the ratio of dedication equivalent to 5 acres per 1,000 population, according to the following: single-family dwellings at 740.5 square feet per unit and multi-family dwellings at 675.2 square feet per unit. Based upon the proposed 1,203 single-family homes and 1,746 multi-family homes, 47.6 acres of developed parks and recreation facilities must be provided at Fanita Ranch to satisfy the parkland dedication requirement of 5 acres per 1,000 population pursuant to SMC Section 12.40.070.

Per the public park credit provisions set forth in SMC Section 12.40.110, developed park land dedicated to and maintained by the City of Santee will receive up to 100 percent park credit. Developed park land maintained by an HOA and trail systems will receive up to 50 percent credit per the private park credit provisions in SMC Section 12.40.100. *Table 7.1: Summary of Park and Recreation Land Dedication* identifies the acreage of developed parks and trails provided at Fanita Ranch. The table shows that 78.0 acres of public and private park lands for active and passive recreation, as well as 4.5 acres of trail lands consisting of perimeter trails and the Stowe Trail connections, are planned within Fanita Ranch, for a total of 82.5 acres. 52.4 acres of the total 82.5 acres are available for park land dedication credit, which satisfies the SMC Chapter 12.40, Park Lands Dedication requirement of 5 acres of park land per 1,000 population and results in a surplus of 4.8 acres.

The underlying land use for the S overlay site is medium-density residential (MDR). However, if the 15-acre school site is not acquired for school use within two years of approval of the final map containing the school site, the MDR land use may be implemented on the site, increasing the Specific Plan Area unit count by 59 units for a maximum total of 3,008 units. Should the land use revert to MDR, the developed park land and recreational facility dedication requirement would increase by 0.9 acre (59 multi-family units at 675.2 square feet per unit = 39,837 square feet = 0.9 acre), resulting in a total of park land dedication requirement of 48.5 acres. As stated above, 52.4 acres of park and trail lands within Fanita Ranch are available for park land dedication credit, which would satisfy the SMC Chapter 12.40, Park Lands Dedication requirement and results in a surplus of 3.9 acres should the land use for the S overlay site revert to MDR.





**LEGEND**

**Parks**

- Community Park (CP-#)
- Neighborhood Park (NP-#)
- Mini Parks (MP-#)

**Compacted Earth or DG Trails**

- Perimeter Trails (8' wide)
- Village Nature Trails (6' wide)
- Nature Trails (4' wide)
- Primitive Trails (Exist. or 2.5' wide)
- SDG&E Service Road (Existing)

**Concrete Trails**

- Multi-Purpose Trails
  - Fanita Parkway (10' wide)
  - Cuyamaca Street (8' wide)
- Village Access Trails
  - Village Center (10' wide)
  - Village Connection (6' wide)

**Trailhead**

**Potential Trail Access Point**

**Trail Staging Area** \*

Note: Refer to Chapter 4.0 Mobility for detailed trail information.

not to scale For illustrative purposes only; final design may vary.

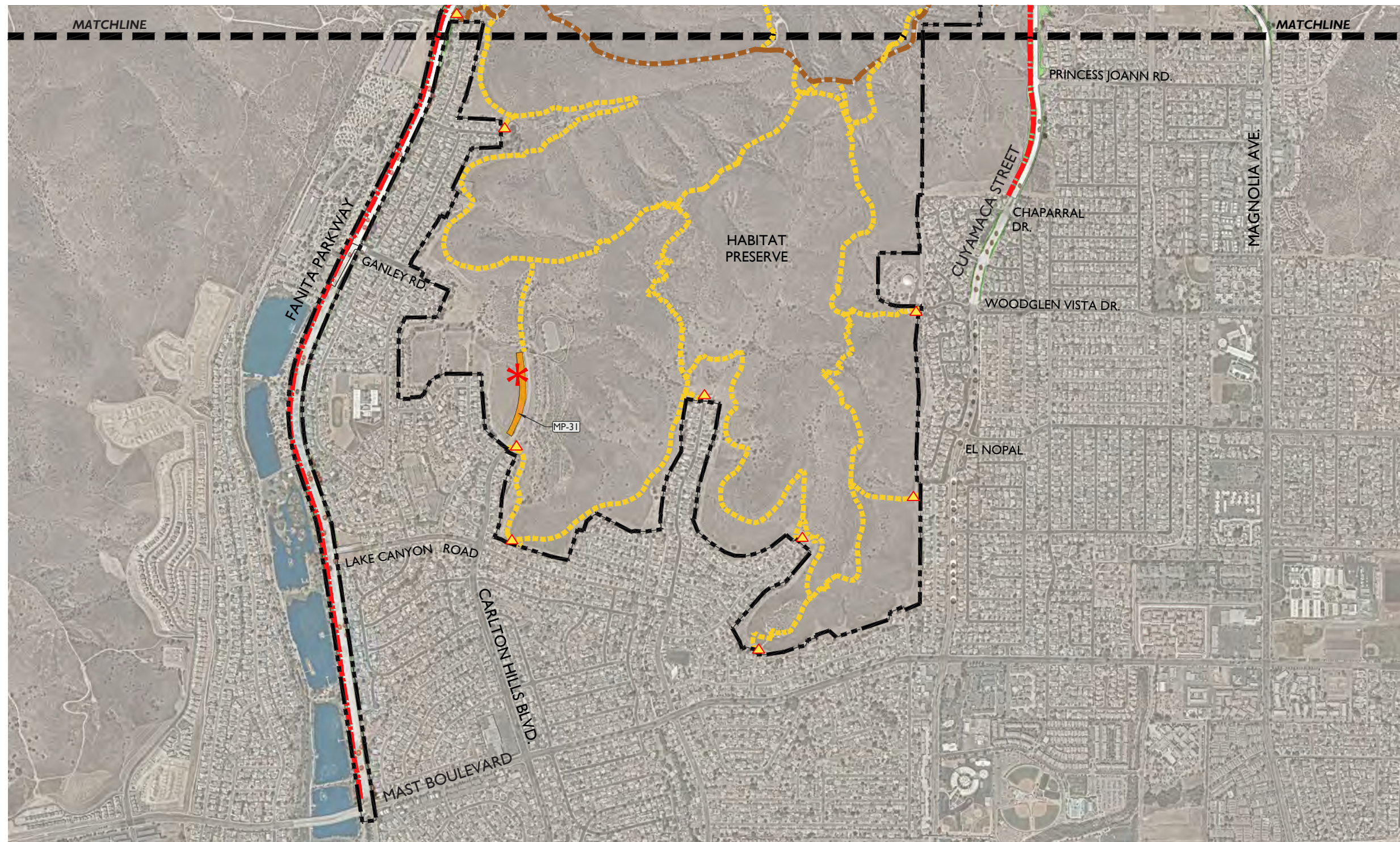
Match Line: See Exhibit 7.1b

not to scale

**Exhibit 7.1a: Conceptual Park, Recreation & Open Space Plan (North)**



Match Line: See Exhibit 7.1a



**LEGEND**

- Parks**
    - Community Park
    - Neighborhood Parks
    - Mini Parks
  - Compacted Earth or DG Trails**
    - Perimeter Trails (8' wide)
    - Village Nature Trails (6' wide)
    - Nature Trails (4'wide)
    - Primitive Trails (Exist. or 2.5'wide)
    - SDG&E Service Road (Existing)
  - Concrete Trails**
    - Multi-Purpose Trails
      - Fanita Parkway (10' wide )
      - Cuyamaca Street (8' wide)
    - Village Access Trails
      - Village Center (10' wide )
      - Village Connection (6' wide)
  - Trailhead
  - Potential Trail Access Point
  - \* Trail Staging Area
- Note: Refer to Chapter 4.0 Mobility for detailed trail information.

**Exhibit 7.1b: Conceptual Park, Recreation & Open Space Plan (South)**

For illustrative purposes only; final design may vary. not to scale



**Table 7.1: Summary of Park and Recreation Land Dedication**

<b>Park Land Dedication Requirement<sup>1</sup></b>			
Dwelling Type	Square Feet Per Unit <sup>1</sup>	Number of Units <sup>2</sup>	Required Acreage
Single-Family	740.5	1,203	20.5
Multi-Family	675.2	1,746	27.1
<b>Total Park Land Dedication Requirement</b>		<b>2,949</b>	<b>47.6</b>
<b>Park Land Provided</b>			
Park Type	Percentage Credit	Acreage <sup>3,4</sup>	Credit Acreage <sup>4,5</sup>
Community Park - Active	100%	19.7	18.4
Community Park - Passive	50%	11.5	5.8
Neighborhood Park 1	50%	4.6	2.3
Neighborhood Park 2	50%	3.3	1.7
Neighborhood Park 3 (Linear Park)	50%	3.2	1.6
Neighborhood Park 4	50%	2.6	1.3
Neighborhood Park 5	50%	5.3	2.7
Neighborhood Park 6	50%	3.4	1.7
Neighborhood Park 7	50%	3.8	1.9
Neighborhood Park 8	100%	4.2	4.2
Mini Park 1 (Village Green)	50%	1.6	0.8
Mini Park 2 (Linear Park)	50%	1.7	0.9
Mini Park 3	50%	0.2	0.1
Mini Park 4	50%	0.4	0.2
Mini Park 5	50%	0.4	0.2
Mini Park 6	50%	0.2	0.1
Mini Park 7	50%	0.1	0.1
Mini Park 8	50%	0.4	0.2
Mini Park 9	50%	0.3	0.2
Mini Park 10	50%	0.2	0.1
Mini Park 11	50%	2.1	1.1
Mini Park 12	50%	1.7	0.9
Mini Park 13	50%	0.8	0.4
Mini Park 14	50%	0.3	0.2
Mini Park 15	50%	0.1	0.1
Mini Park 16	50%	0.2	0.1
Mini Park 17	50%	0.4	0.2
Mini Park 18	50%	0.3	0.2
Mini Park 19	50%	0.2	0.1
Mini Park 20	50%	1.0	0.5
Mini Park 21	50%	0.3	0.2
Mini Park 30	50%	1.6	0.8
Mini Park 31	50%	1.6	0.8
Mini Parks 22 to 29 (Paseos)	0%	0.6	0.0
<b>Estimated Park Acreage</b>		<b>78.0</b>	<b>50.1</b>



**Table 7.1: Summary of Park and Recreation Land Dedication (continued)**

<b>Trail Land Provided</b>			
Trail Type - Trail Width (Assumed) <sup>6</sup>	Total		50% Credit
	Length (L.F.)	Acreage <sup>3,4</sup>	Acreage <sup>4,5</sup>
Perimeter - 8'	21,116	3.9	2.0
Stowe Trail Connection to Sycamore Canyon - (6' min)	4,207	0.6	0.3
<b>Estimated Trails</b>	<b>4.8 Miles</b>	<b>4.5</b>	<b>2.3</b>
<b>Estimated Park &amp; Trail Acreage</b>		<b>82.5</b>	<b>52.4</b>
<b>Required Park &amp; Trail Acreage</b>			<b>47.6</b>
<b>Estimated Park &amp; Trail Acreage Surplus</b>			<b>4.8</b>

Notes:

1. Per Santee Municipal Code (SMC) Section 12.40.070.
2. Actual number and type of units will be finalized during the final mapping process.
3. Acreage rounded to the nearest tenth and may vary slightly from the Vesting Tentative Map.
4. Acreage rounded to the nearest tenth and may vary slightly from the calculated total.
5. Neighborhood parks, mini parks (except mini parks 22 to 29) and trails proposed to be HOA maintained are credited at 50% of net acreage per SMC Section 12.40.100. Community park is credited at 100% of usable pad area acreage per SMC Section 12.40.110.
6. Existing trail width varies. Regional trail connection to be improved to minimum 6' wide.

## 7.3 Park and Recreation Concepts

A hierarchy of parks is provided throughout the Specific Plan Area. The Community Park in Fanita Commons will provide the primary location for active and organized recreational activities within Fanita Ranch. Neighborhood parks are provided in key locations to define neighborhoods and provide community gathering spaces. Mini-parks are designed to enhance open space areas such as vistas and riparian corridors, break up development patterns and provide visual relief. Mini-parks create diversity and interest as well as provide recreational opportunities within walking distance of all homes. The Village Green is a special mini-park that will complement the Village Center and the Farm to establish a centralized landmark and event space for the entire community. Park designs shall be consistent with the Fanita Ranch Fire Protection Plan.

Utilizing the proposed trail, path and sidewalk system, the AgMeander will provide numerous interpretive stations and exhibits. Potential AgMeander stops include farm fields, orchards, vineyards, edible landscapes, pollinator gardens, community gardens and scenic viewpoints.

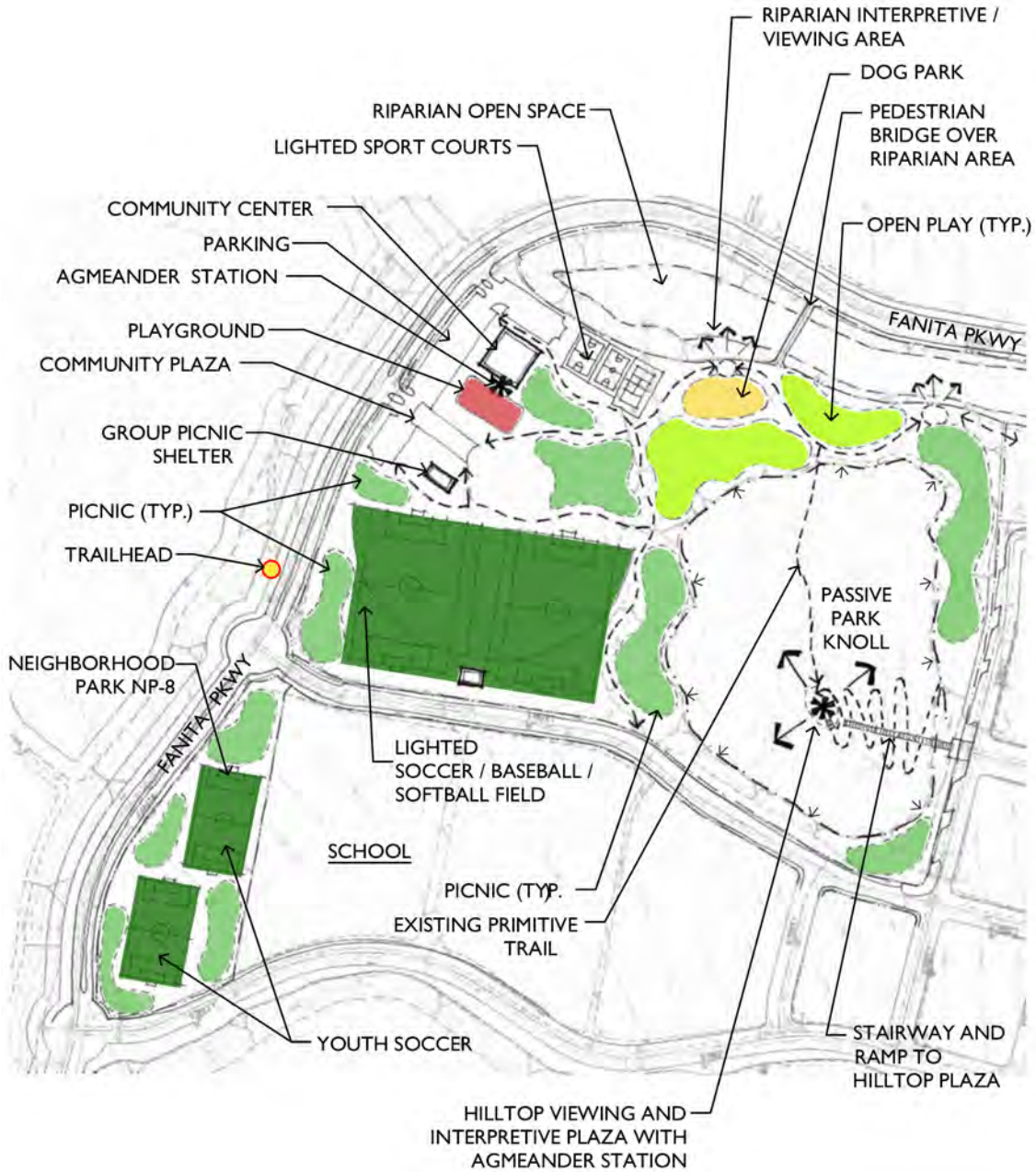
### 7.3.1 Community Park

The 31.2-acre Community Park is located in the Fanita Commons Village. *Exhibit 7.2: Community Park Concept Plan* illustrates one potential layout for the Community Park. The Community Park will include two multi-purpose ballfields, sport courts, restrooms, parking, tot lots, open play areas, and passive picnicking areas, and may include an aquatic element, community gathering plaza and dog park.

Within the Community Park, a 7,000 to 10,000 square-foot community center will provide multi-purpose, flexible spaces to support recreation, learning, arts and crafts, social and service functions. The community center will also provide support spaces such as staff offices, reception area, restroom and storage areas.


Trails will meander throughout the park, including the passive eastern knoll. The park will serve as a visual landmark by preserving the eastern knoll, which contains natural rock formations and a unique geographical character that defines the existing Fanita Ranch landscape. A knoll-top lookout will provide panoramic views, seating and educational elements. The entire park will be owned, maintained and programmed by the City of Santee.

In addition, the Community Park will include AgMeander stations and other elements tied to the agricultural theme of Fanita Ranch. These elements may include a pollinator garden, edible landscaping and proposed knoll-top lookout. Along the north side of the park, overlooks and interpretive elements will inform residents of the beauty and importance of the adjacent riparian environment.



*For illustrative purposes only; final design may vary.*

**Exhibit 7.2: Community Park Conceptual Plan**

 *not to scale*



The Community Park is located adjacent to a proposed 15-acre school site. Connections between the park and school site would create a strong relationship between these uses. The park may function as an extension of the school and offer activities for play as well as education. The interrelationship between the park and school would be supported by the adjacent 4.2-acre neighborhood park. This neighborhood park may include play fields, open play areas and other amenities. The neighborhood park will be owned, maintained and programmed by the City of Santee. In the event that the school site is not developed as a school, the S-1 site shown on *Exhibit 3.2: Site Utilization Plan* would revert to its underlying medium density residential land use.





### A. Potential Amenities & Facilities

- Lighted multipurpose sports fields
- Play equipment<sup>1</sup>
- Lighted sports courts
- Seating
- Group and individual picnic shelters
- Open play area
- Community plaza
- Passive recreation and shaded picnic areas
- Riparian area overlooks
- 7,000 - 10,000 s.f. community building
- Parking
- Restrooms
- Trail, stairway and accessible ramp to the top of the passive park knoll
- Connections to community and regional trails as shown on *Exhibit 7.1: Conceptual Park, Recreation & Open Space Plan*
- Dog park
- Adult exercise equipment
- Running / walking DG track
- Aquatic resource elements
- Arbors or trellises
- AgMeander Stations

### B. Hardscape Materials

- Sports courts, gathering plazas and primary walkways – low albedo concrete
- Parking areas – asphalt
- Nature trails – decomposed granite or compacted native earth

### C. Lighting Standards

- Pedestrian scaled walkway lighting
- Sport field and court lighting
- Security lighting
- Shielding standards required adjacent to Habitat Preserve

### D. Representative Plant Palette

- Refer to *Exhibit 5.10: Fanita Commons Plant Palette*.
- 1. *Play structures in the parks shall be of non-combustible or other materials approved by the Santee Fire Department.*



## E. Representative Plant Palette

### Trees



PLATANUS RACEMOSA -  
California Sycamore



CINNAMOMUM CAMPHORA -  
Camphor Tree



JACARANDA MIMOSIFOLIA-  
Jacaranda

#### Trees List:

- ALNUS RHOMBIFOLIA / White Alder
- CINNAMOMUM CAMPHORA / Camphor Tree
- JACARANDA MIMOSIFOLIA / Jacaranda
- KOELREUTERIA PANICULATA / Golden Rain Tree
- LIQUIDAMBAR STYRACIFLUA / Sweet Gum
- PLATANUS RACEMOSA / California Sycamore

#### Edible Trees List:

- ARBUTUS UNEDO - Strawberry Tree
- CERATONIA SILIQUA - Carob Tree
- JUGLANS CALIFORNICA - California Walnut
- LAURUS NOBILIS - Sweet Bay

### Shrubs/Perennials/Edibles/Medicinals



CEANOTHUS SP. -California Lilac



LANTANA SP. -Lantana



PHORMIUM SP.- New Zealand Flax

#### Shrubs List:

- ALOE SP. / Aloe
- CEANOTHUS SP. / California Lilac
- CISTUS SP. / Rockrose
- FESTUCA MAIREI / Atlas Fescue
- GALVEZIA SPECIOSA / Island Snapdragon
- IVA HAYESIANA / Hayes Iva
- LANTANA SP. / Lantana
- PHORMIUM SP. / New Zealand Flax
- RHAMNUS CALIFORNICA 'MOUND SAN BRUNO' / Coffeeberry
- RHAPHIOLAPIS SP. / Indian Hawthorne

#### Groundcovers List:

- BACCHARIS P. 'PIGEON POINT' / Dwarf Coyote Bush
- CEANOTHUS SP. / California Lilac
- MYOPORUM PARVIFOLIUM 'PINK' / Pink Myoporum

#### Edibles/Medicinals List:

- ALOE VERA - Aloe Vera
- ALOYSIA TRIPHYLLA - Lemon Verbena
- LAVANDULA STOECHAS - Spanish Lavender

### 7.3.2 Neighborhood Parks

Fanita Ranch includes a total of 8 neighborhood parks. *Exhibit 7.3: Typical Neighborhood Park Concept Plans* illustrates two potential layouts for a typical neighborhood park – one active recreation oriented and one non-sports use oriented. Although these parks are smaller in size, they will offer similar recreational features as the Community Park but at a smaller scale. Amenities may include open play fields with benches, fencing and backstops when appropriate, playgrounds, sport courts, gardens, picnic facilities, and restrooms. Some will have trailheads and viewpoints. Sport courts and active sport fields will not be lighted for nighttime use. Neighborhood parks are proposed to be HOA maintained (except for the neighborhood park adjacent to the school site which will be owned, maintained and programmed by the City – see “NP-8” on *Exhibit 3.2: Site Utilization Plan*) and are designed as defining features for the Village to help create identity and support the neighborhood character. Due to their proximity to homes, most neighborhood park users may walk to the parks, therefore parking will be limited to on-street spaces unless adjacent street grade necessitates on-site accessible parking.

#### A. Potential Amenities & Facilities

- Open play areas suitable for organized sport practices or neighborhood social events
- Passive use/picnic areas
- Connections to community and regional trails where shown on *Exhibit 7.1: Conceptual Park, Recreation & Open Space Plan*
- Seating
- Shade
- Sports courts
- Play equipment<sup>1</sup>
- Community garden (at HOA parks)
- Small group and individual picnic shelters
- Shade arbor or trellis
- Pollinator garden
- Neighborhood multi-generational garden (at HOA parks)
- Event green for neighborhood social events
- Greenhouse (at HOA parks)
- Trailhead and/or viewpoints
- AgMeander stations
- Gathering plazas
- Restrooms
- Landscape interpretive station

#### B. Hardscape Materials

- Sport courts, gathering plazas and primary walkways – low albedo concrete
- Secondary walkways and informal park plazas – decomposed granite

#### C. Lighting Standards

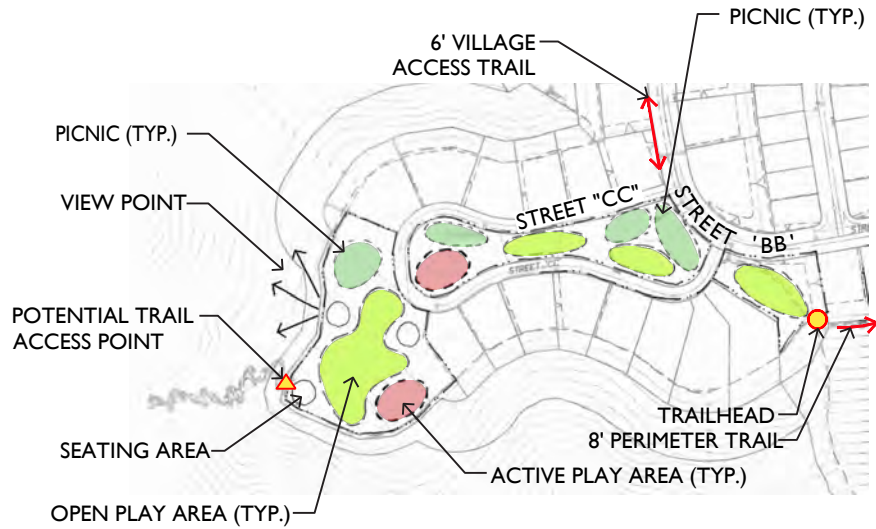
- Pedestrian scaled lighting
- Security lighting
- Shielding standards required adjacent to Habitat Preserve

#### D. Representative Plant Palette

- Refer to *Chapter 5: Landscape Architecture, Community Design & Outdoor Lighting Design Plan* for the appropriate Village plant palette.

1. Play structures in the parks shall be of non-combustible or other materials approved by the Santee Fire Department.



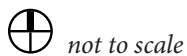


Non-sports Type Neighborhood Park (NP-7)



Active Type Neighborhood Park (NP-5)

*For illustrative purposes only; final design may vary.*



**Exhibit 7.3: Typical Neighborhood Park Concept Plans**



### 7.3.3 Village Green

*Exhibit 7.4: Typical Village Green Concept* illustrates a conceptual plan for the Village Green mini park located in Fanita Commons. The Village Green provides multi-purpose space that will accommodate performances, art fairs, outdoor movies and other social functions. In addition, it can provide a focal point for larger community festivals, with connections to the Farm and Farmer’s Market across Cuyamaca Street, the mixed-use Village Center and Community Park. When not in use for community events, the large open turf area, with possible shade trellises and seating along the perimeter, will provide passive use spaces for Fanita Commons residents. The Village Green is a mini-park proposed to be HOA programmed and maintained and all parking will be on the adjacent streets unless adjacent street grades necessitates on-site accessible parking.

#### A. Potential Amenities & Facilities

- Community focal point such as a sculpture, fountain, or small structure
- Seating
- Large multi-purpose lawn area
- Shade
- Gazebo or pavilion
- Shade structures or tree bosque
- Extensive seating on the perimeter



#### B. Hardscape Materials

- Enhanced decorative pavements



#### C. Lighting Standards

- Pedestrian scaled lighting
- Decorative landscape lighting
- Bollards lights

#### D. Representative Plant Palette

- Refer to *Exhibit 5.10: Fanita Commons Plant Palette*



## E. Representative Plant Palette

### Trees



PLATANUS RACEMOSA -  
California Sycamore



CINNAMOMUM CAMPHORA -  
Camphor Tree



JACARANDA MIMOSIFOLIA-  
Jacaranda

### Trees List:

- CINNAMOMUM CAMPHORA / Camphor Tree
- JACARANDA MIMOSIFOLIA / Jacaranda
- KOELREUTERIA PANICULATA / Golden Rain Tree
- PLATANUS RACEMOSA / California Sycamore

### Shrubs/Perennials/Edibles/Medicinals



CISTUS SP. -  
Rockrose



CRASSULA MULTICAVA -  
Fairy Crassula



WISTERIA SINENSIS -  
Wisteria

### Shrubs List:

- BUDDLEJA SP. / Butterfly Bush
- CEANOTHUS SP. / California Lilac
- CISTUS SP. / Rockrose
- FESTUCA MAIREI / Atlas Fescue
- GALVEZIA SPECIOSA / Island Snapdragon
- GREVILLEA CULTIVARS / Grevillea
- LEUCOPHYLLUM SP. / Texas Sage
- PHORMIUM SP. / New Zealand Flax
- RHAPHIOLAPIS SP. / Indian Hawthorne

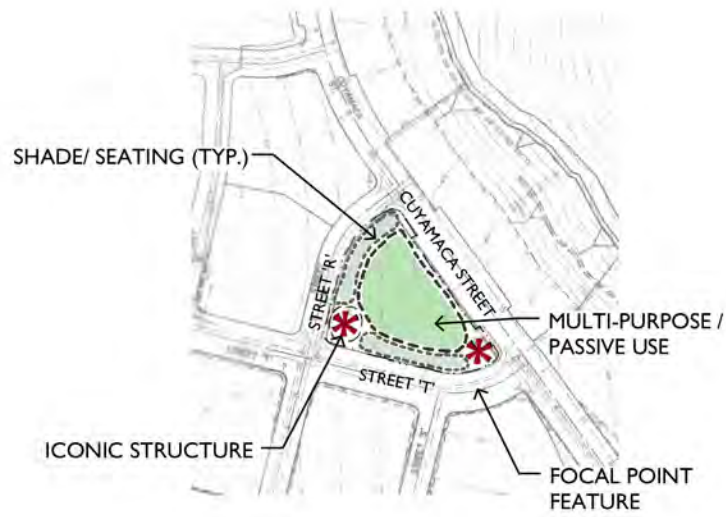
### Groundcovers List:

- CRASSULA MULTICAVA / Fairy Crassula
- FRAGARIA CHILOENSIS / Ornamental Strawberry
- MYOPORUM PARVIFOLIUM 'PINK' / Pink Myoporum

### Vines List:


- JASMINUM SP. / Jasmine
- WISTERIA SINENSIS / Wisteria





*For illustrative purposes only; final design may vary.*

### Exhibit 7.4: Village Green Concept Plan

 not to scale



### 7.3.4 Mini-Parks

*Exhibit 7.5: Typical Mini-Park Concept Plan* demonstrates how the 31 small mini-parks distributed throughout the community can provide opportunities for recreation, activity and relaxation within walking distance of the homes. Many will be access points for the trail system and will be access points for firefighters and brush management maintenance personnel. Mini-parks are proposed to be HOA owned and maintained. Mini-parks are intended to serve residents who live within walking distance and will not have on-site parking facilities except as necessary to accommodate accessible parking.

#### A. Potential Amenities & Facilities

- Shade trees
- Seating
- Connections to community and regional trails where shown on *Exhibit 7.1: Conceptual Park, Recreation & Open Space Plan*
- AgMeander stations
- Native and drought tolerant landscape interpretive stations
- Passive lawn or lawn-like areas
- Shade arbors or trellises
- View point maps or distant mountain identification signs
- Pollinator garden
- Community garden
- Walkways
- Individual picnic areas

#### B. Hardscape Materials

- High use areas – low albedo concrete
- All other areas – decomposed granite or compacted native earth
- Trail Connections – decomposed granite or compacted native earth

#### C. Lighting Standards

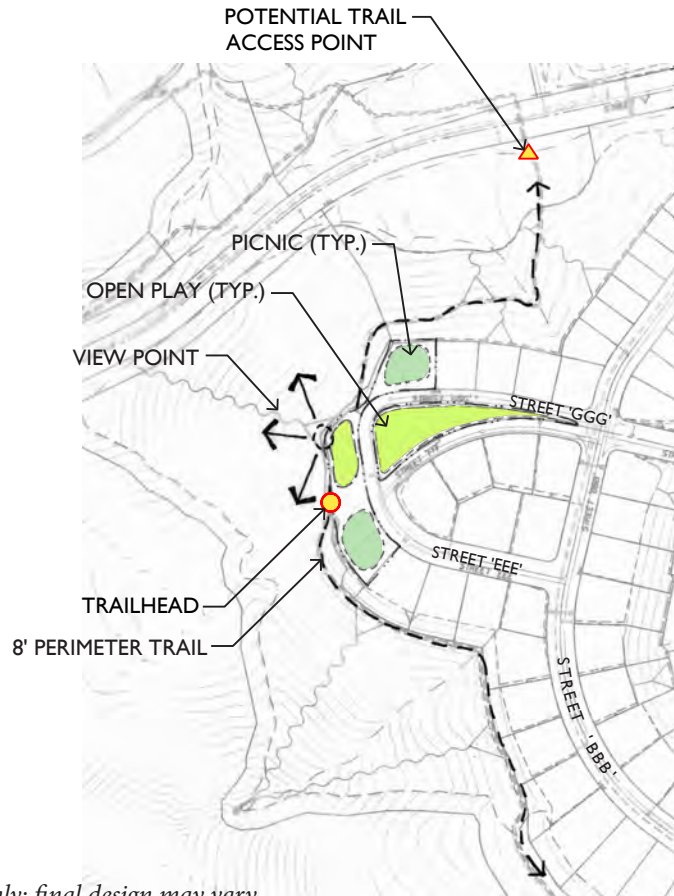
- Pedestrian scaled lighting (where appropriate)
- Bollards
- Shielding standards required adjacent to Habitat Preserve

#### D. Representative Plant Palette

- Refer to *Chapter 5: Landscape Architecture, Community Design & Outdoor Lighting Design Plan* for the appropriate Village plant palette.








*For illustrative purposes only; final design may vary.*

**Exhibit 7.5: Typical Mini-Park Concept Plan (MP-20)**

 *not to scale*



### 7.3.5 AgMeander

The planned AgMeander is a series of trails and paths that unite nature and agriculture in an experiential journey. While the Farm is the agriculture heart of Fanita Ranch, the AgMeander, as depicted in *Exhibit 7.6: Conceptual AgMeander Plan*, utilizes community trails that connect the Farm to the Villages, school and parks. This plan expands the food concept beyond just commercial production. It provides context for food production and is an example of how everyday landscape can be ornamental and edible.

AgMeander information may be available in numerous forms including traditional interpretive signage, website and audio for the visually impaired. The AgMeander is proposed to be HOA programmed, owned and maintained except where it traverses city-owned parks.

#### A. Potential Amenities & Facilities

- Accessible pathways with distance markers
- Occasional seating
- Occasional shade areas
- Access to vineyards, orchards, row crops, edible landscapes and pollinator gardens.
- Access to food production processes from germination to harvest to compost
- Interpretive signage and exhibits, vineyards, orchards, row crops, edible landscapes, production processes and composting
- Access to farm equipment and tools



#### Potential AgMeander Stations

##### *Local AgMeander:*

- Start location: farm event barn. Numerous farm related activities display farm-to-table opportunities and a calendar of harvest and farm related activities.
- Accessible hilltop lookout point with shade structure and community view orientation maps.



**Local AgMeander (continued)**

- Active Adult community garden, focus on health-oriented and medicinal plant information
- Wildlife crossing information and observation point
- North Trail Vista Point in Vineyard Village, with information regarding native chaparral and other naturally occurring edible plants
- East Trail Vista Point in Vineyard Village, with supplemental native oak plantings for shade and education
- Vineyard Village vineyard with grape harvest opportunity
- Working farm compound and orchard food forest
- Open space preserve trail with opportunities for observing Habitat Preserve
- Orchard Village Center with possible community garden and outdoor kitchen opportunity
- Orchard Village orchard and overlook of riparian corridor with water quality education and orchard harvest opportunities
- Community center building located in Community Park

**Regional AgMeander:**

- Fanita Parkway and roundabout with boulders. Sycamores and endemic cactus plantings and overlook of water reclamation plant and MCAS Miramar military base to the west
- Santee Lakes recreation area with free entry for AgMeander users

- Solar farm in Special Use area, including educational displays regarding sustainability and carbon neutral aspects of Fanita Ranch
- Rustic open space trail corridor leading back to the northern villages with trailside displays of native vegetation

**B. Hardscape Materials**

- High use areas – low albedo concrete
- All other areas – decomposed granite, compacted native earth, gravel or bark mulch

**C. Lighting Standards**

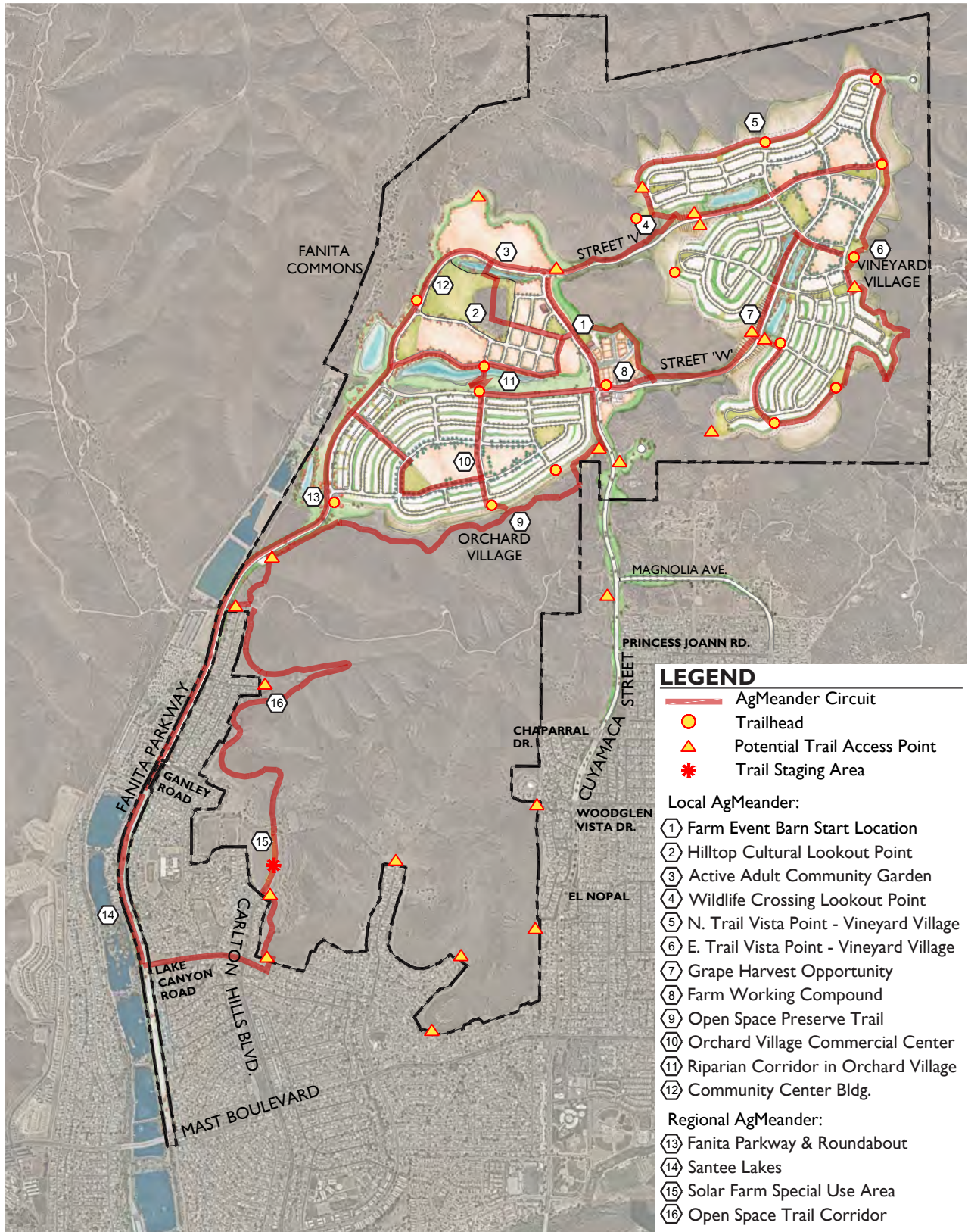
- Pedestrian scaled lighting in urban areas (where appropriate)

**D. Representative Plant Palette**

- Refer to *Chapter 5: Landscape Architecture, Community Design & Outdoor Lighting Design Plan* for the appropriate Village plant palette.







*For illustrative purposes only; final design may vary.*

not to scale

**Exhibit 7.6: Conceptual AgMeander Plan**



### 7.3.6 Linear Parks

Two Linear Parks flank the large southerly riparian area - a mini-park (MP-2) on the north side and a neighborhood park (NP-3) on the south side. They will provide visual relief between the Fanita Commons to the north and the Orchard Village to the south. The riparian character of Fanita Parkway will be continued to the west along Street “A” to Cuyamaca Street. In addition, the linear parks will be an important component of the AgMeander system, connecting the school and Orchard Village residences to the Farm via a series of naturalistic paths. AgMeander and native landscape stations will provide informative resting places along the nearly two miles of linear park paths. Linear parks are proposed to be HOA maintained.

#### A. Potential Amenities & Facilities

- Riparian landscape
- AgMeander stations
- Riparian interpretive stations
- Seating
- Shade
- Edible landscape
- Bridge across the riparian area
- Agricultural landscape

#### B. Hardscape Materials

- Nature Trails – decomposed granite or compacted native earth
- Village Access Trails – low albedo concrete

#### C. Lighting Standards

- Pedestrian scaled lighting (where appropriate)
- Shielding standards required adjacent to Habitat Preserve



## D. Representative Plant Palette

### Trees



PLATANUS RACEMOSA -  
California Sycamore



ALNUS RHOMBIFOLIA -  
White Alder



CERCIS OCCIDENTALIS-  
Western Redbud

#### Trees List:

- CERCIS OCCIDENTALIS - Western Redbud Multi-Trunk
- POPULUS FREMONTII - Fremont Cottonwood
- QUERCUS AGRIFOLIA - Coast Live Oak
- SALIX GOODINGII - Black Willow
- SALIX LASIOLEPIS - Arroyo Willow
- SAMBUCUS MEXICANA - Mexican Elderberry

#### Edible Trees List:

- ARBUTUS UNEDO - Strawberry Tree
- CERATONIA SILIQUA - Carob Tree
- JUGLANS CALIFORNICA - California Walnut
- LAURUS NOBILIS - Sweet Bay
- MALUS DOMESTICA 'HONEYCRISP' - Honeycrisp Apple
- PERSEA AMERICANA 'HASS' / Avocado (To be maintained per FPP)

### Shrubs/Perennials/Edibles/Medicinals



RIBES SPECIOSUM -  
Fuchsiaflower Gooseberry



LEYMUS C. 'CANYON PRINCE' -  
Canon Prince Wild Rye



AECHILLEA MILLEFOLIUM-  
Yarrow

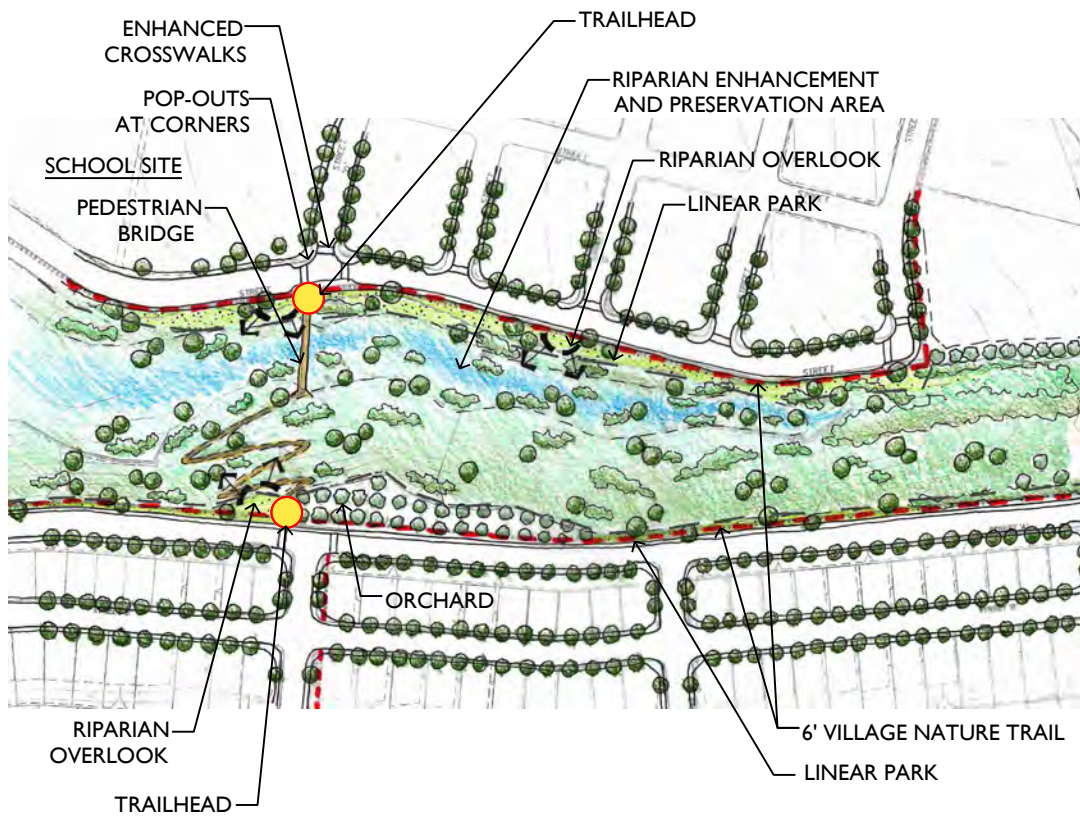
#### Shrubs List:

- ACHILLEA MILLEFOLIUM - Yarrow
- ANEMOPSIS CALIFORNICA - Yerba Mansa
- ASCLEPIAS FASCICULARIS - Narrow-Leaf Milkweed
- FESTUCA MAIREI - Atlas Fescue
- IRIS DOUGLASIANA - Douglas Iris
- LEYMUS CONDENSATUS 'CANYON PRINCE' - Canyon Prince Wild Rye
- ROSA CALIFORNICA - California Rose
- SYSYRINCHIUM BELLUM - Blue-Eyed Grass

#### Edibles/Medicinals List:


- ALOE VERA - Aloe Vera
- ALOYSIA TRIPHYLLA - Lemon Verbena
- LAVANDULA STOECHAS - Spanish Lavender
- OPUNTIA FICUS-INDICA - Prickly Pear Or Nopales
- SALVIA OFFICINALIS - Sage
- SIMMONDSIA CHINENSIS - Jojoba
- THYMUS VULGARIS - English Thyme
- VITIS CALIFORNICA - California Grape





*For illustrative purposes only; final design may vary.*

**Exhibit 7.7: Typical Linear Park Plan**

 *not to scale*

### 7.3.7 Typical Vista Points and Trailheads

Vista points and trailheads will include trail connections, seating with accessible spaces for wheelchairs, and shade trees. Other amenities may include AgMeander stations, native culture and landscape interpretive stations, specialty gardens, and passive recreation areas. Trailheads also provide access for firefighters and brush management maintenance personnel. Vista points and trailheads are proposed to be HOA owned and maintained except where they are integrated into City owned parks.

#### A. Potential Amenities & Facilities

- Seating with accessible space
- Shade trees
- Trail connections where shown on *Exhibit 7.1: Conceptual Park, Recreation & Open Space Plan*
- AgMeander stations
- Edible landscape station
- Pollinator garden
- Vista interpretive signage
- Shade arbor or structure



#### B. Hardscape Materials

- High Traffic Areas – low albedo concrete
- All Other Areas - decomposed granite or compacted native earth



#### C. Lighting Standards

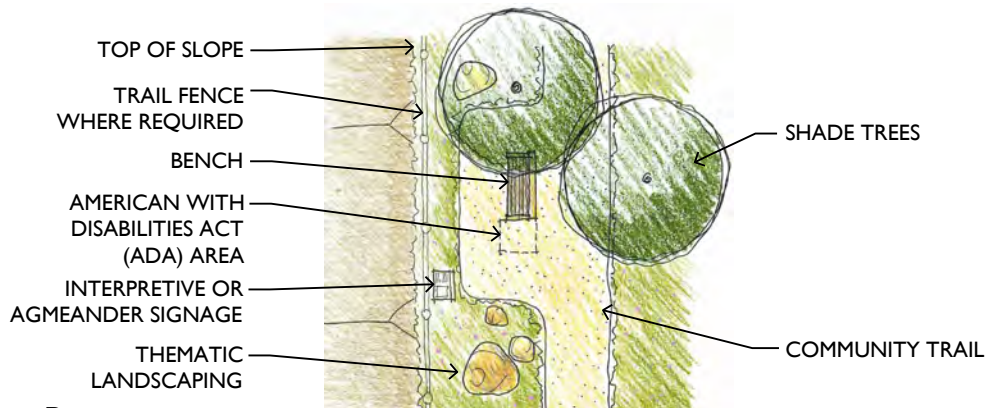
- Pedestrian scaled lighting (where appropriate)
- Shielding standards required adjacent to Habitat Preserve

#### D. Representative Plant Palette

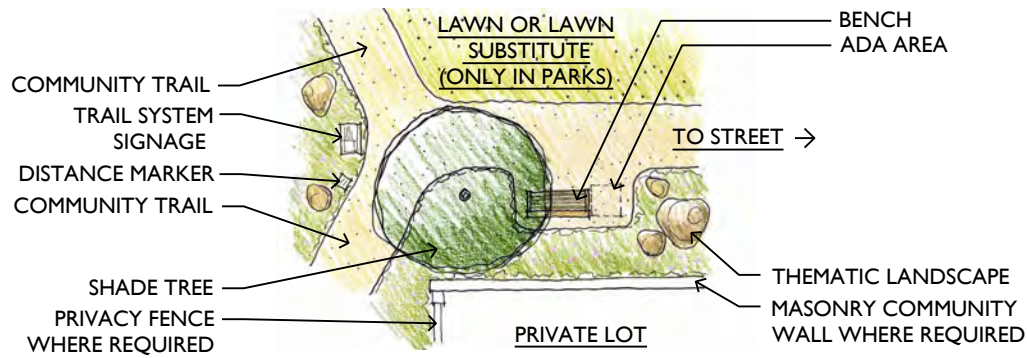
- Refer to *Chapter 5: Landscape Architecture, Community Design & Outdoor Lighting Design Plan* for the appropriate Village plant palette.



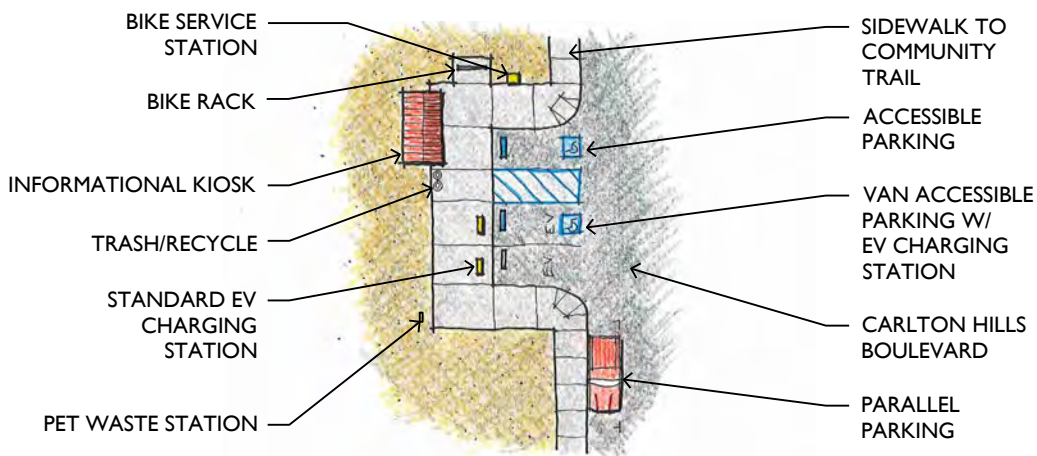




**View Point**



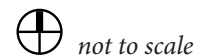
**Improved Trailhead**



**Trail Staging Area**

*For illustrative purposes only; final design may vary.*

**Exhibit 7.8: Typical Vista Point and Trailhead Concept Plan**



## 7.4 Other Recreation and Open Space Areas

The Goal of the Santee General Plan Recreation Element is “to provide a system of public parks and recreational facilities which serve the citizens of Santee.” Objective 1.0 of the Recreation Element is to “Provide a minimum of 10 acres of parks and recreation facilities for every 1,000 population in Santee. These 10 acres could include a combination of local parks, trails, school playgrounds and other public facilities that meet part of the need for local recreational facilities.”

The Specific Plan includes a wide range of parks, trails and other recreation and open space areas that meet Santee General Plan Recreation Element Objective 1.0. As discussed in *Section 7.2: Park Land Dedication* of the Specific Plan, a total of 82.5 acres of public and private park lands for active and passive recreation (78.0 acres) and trail lands (4.5 acres) are planned within Fanita Ranch, of which 52.4 acres are available for park land dedication credit. After satisfying SMC Chapter 12.40, Park Lands Dedication requirement of 5 acres of park land per 1,000 population (which equates to 47.6 acres), there is a surplus of 4.8 acres available to meet a portion of the remaining 5 acres per 1,000 population required by General Plan Recreation Element Objective 1.0. Based on the same average occupancy rate per dwelling type and the ratio equivalent to 5 acres per 1,000 population used in *Section 7.2*, a total of 47.6 acres of parks, other recreation and open space areas is needed to meet the remaining parks and recreation facilities required by Recreation Element Objective 1.0. Fanita Ranch meets this objective through a combination of public and private park land, open space areas, the farm and multi-purpose trails, as shown in *Table 7.2: Other Recreation and Open Space Areas*.

**Table 7.2: Other Recreation and Open Space Areas**

<b>Other Recreation &amp; Open Space Area Objective</b>			
Dwelling Type	Square Feet Per Unit <sup>1</sup>	Number of Units <sup>2</sup>	Objective Acreage <sup>3</sup>
Low Density	740.5	1,203	20.5
Medium Density	675.2	1,746	27.1
<b>Other Recreation &amp; Open Space Area Objective</b>		<b>2,949</b>	<b>47.6</b>

<b>Other Recreation &amp; Open Space Areas Provided</b>	
Other Recreation & Open Space Area Type	Acreage <sup>4</sup>
Surplus Public and Private Park and Trail Land	4.8
Farm	27.3
Open Space Land w/Agricultural Overlay	10.9
Multi-Purpose Trails	6.0
Estimated Other Recreation & Open Space Area Acreage Provided	<b>49.0</b>
Other Recreation & Open Space Area Objective	<b>47.6</b>
Estimated Other Recreation & Open Space Area Acreage Surplus	<b>1.4</b>

Notes:

1. Based on the same average occupancy rate per dwelling type and ratio equivalent to 5 acres per 1,000 population used in *Section 7.2: Park Land Dedication*.
2. Actual number and type of units will be finalized during the final mapping process.
3. Consistent with Santee General Plan Recreation Element Objective 1.0, 10 acres of parks and recreation facilities will be provided for every 1,000 population, including 47.6 acres provided to satisfy the park land dedication of 5 acres per 1,000 population required per SMC 12.40.070 as discussed in *Section 7.2: Park Land Dedication* and 5 acres of other recreation and open space areas per 1,000 residents based on the same average occupancy rate per dwelling type and equivalent ratio used in *Section 7.2: Park Land Dedication*.
4. Acreage rounded to the nearest tenth and may vary slightly from the Vesting Tentative Map.

In addition to the areas described above, playgrounds and other recreational facilities would be provided at the reserved school site should the Santee School District acquire the site and construct a school. Together, these parks, trails, recreation and open space areas will support a broad range of active and passive recreational opportunities to serve the residents and exceed the General Plan Recreation Element Objective 1.0.

# Chapter 8: Grading, Utilities & Services

## 8.1 Grading Plan

*Exhibit 8.1: Conceptual Grading Plan* illustrates the general grading concept for Fanita Ranch. The site will be graded into development pads using a maximum 2:1 slope ratio for fill slopes and a maximum 1.5:1 for cut slopes. Internal manufactured slopes over 40 feet in height that are visible from the public rights-of-way, identified on the plan as “Public Interest” slopes, will utilize land form grading techniques to recreate and mimic the flow of natural contours and drainages within the natural surroundings.

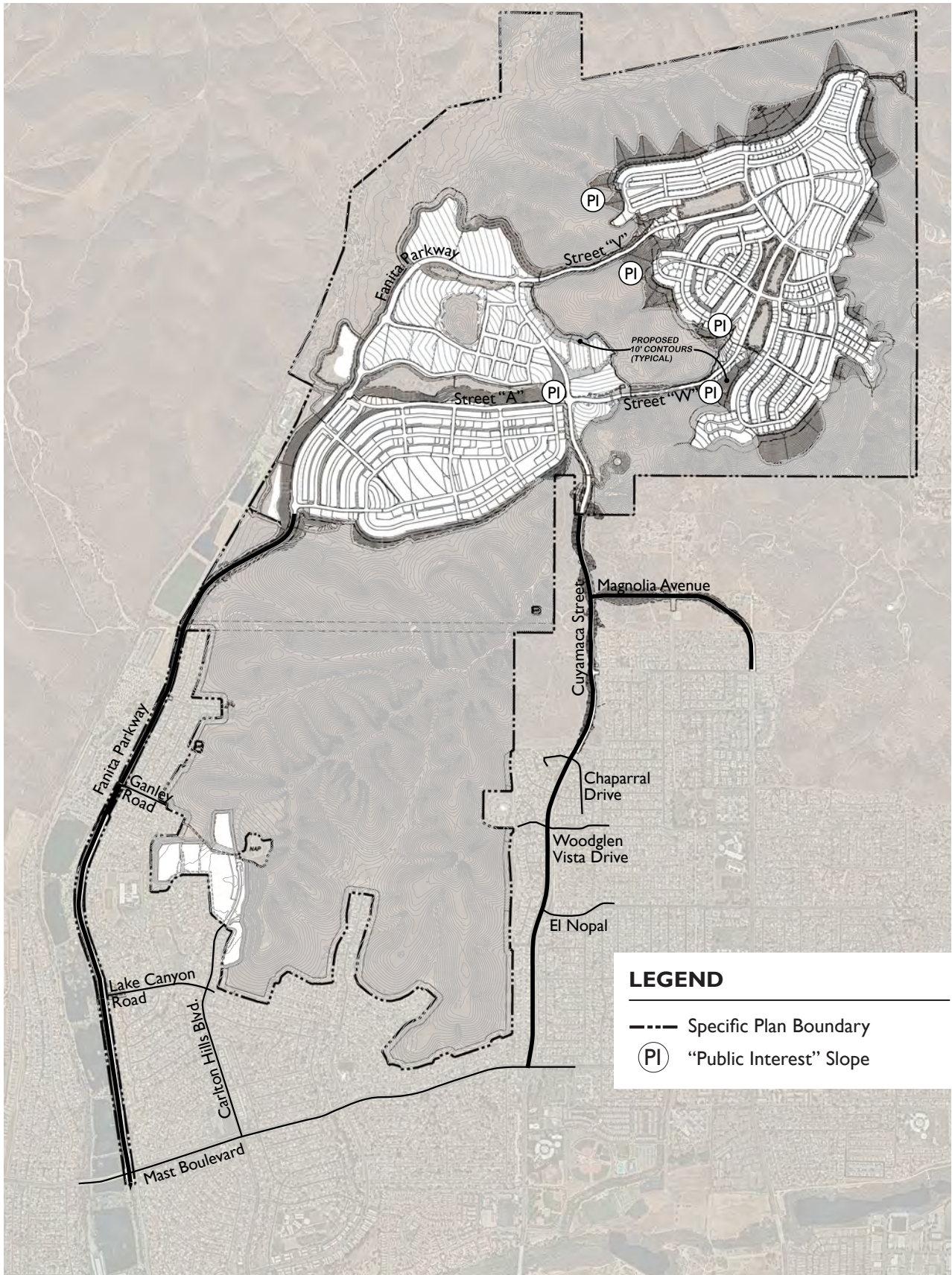
*Exhibit 8.2: Conceptual Cut and Fill* shows the anticipated areas for cut and fill. The overall grading quantity is approximately 27,000,000 cubic yards and the site will be balanced with no import or export for the mass grading operation, which will reduce construction truck traffic. Grading will be contained within the Specific Plan Area boundaries and will only extend beyond the boundaries where off-site grading and infrastructure improvements are required. Cuts up to 165 feet and fills up to 142 feet will occur on portions of Vineyard Village. Fill slopes over 40 feet in height are identified on the Fanita Ranch Vesting Tentative Map for City Council approval. The Special Use area is currently graded and no significant grading is proposed; however, fine grading in conformance with the “*Geotechnical Investigation for Fanita Ranch*” (see Fanita Ranch EIR Appendix G1-G3) may occur depending on the ultimate use of the area.

During construction, temporary aggregate plants will be utilized for rock crushing and production of aggregate materials for use associated in infrastructure construction onsite. The use of the on-site aggregate plants will reduce emissions attributed to transporting materials from off-site to the Specific Plan Area for construction related activities and will terminate at project build-out. Rock crushing activities shall comply with the City’s noise standards<sup>1</sup> and regional air quality standards. All blasting shall be permitted and approved by the Santee Fire Department.


---

1. Drilling and blasting are not anticipated to occur in the same area for more than 10 consecutive work days and would occur during daytime hours. It is anticipated that no more than one blast would occur in one area per day.

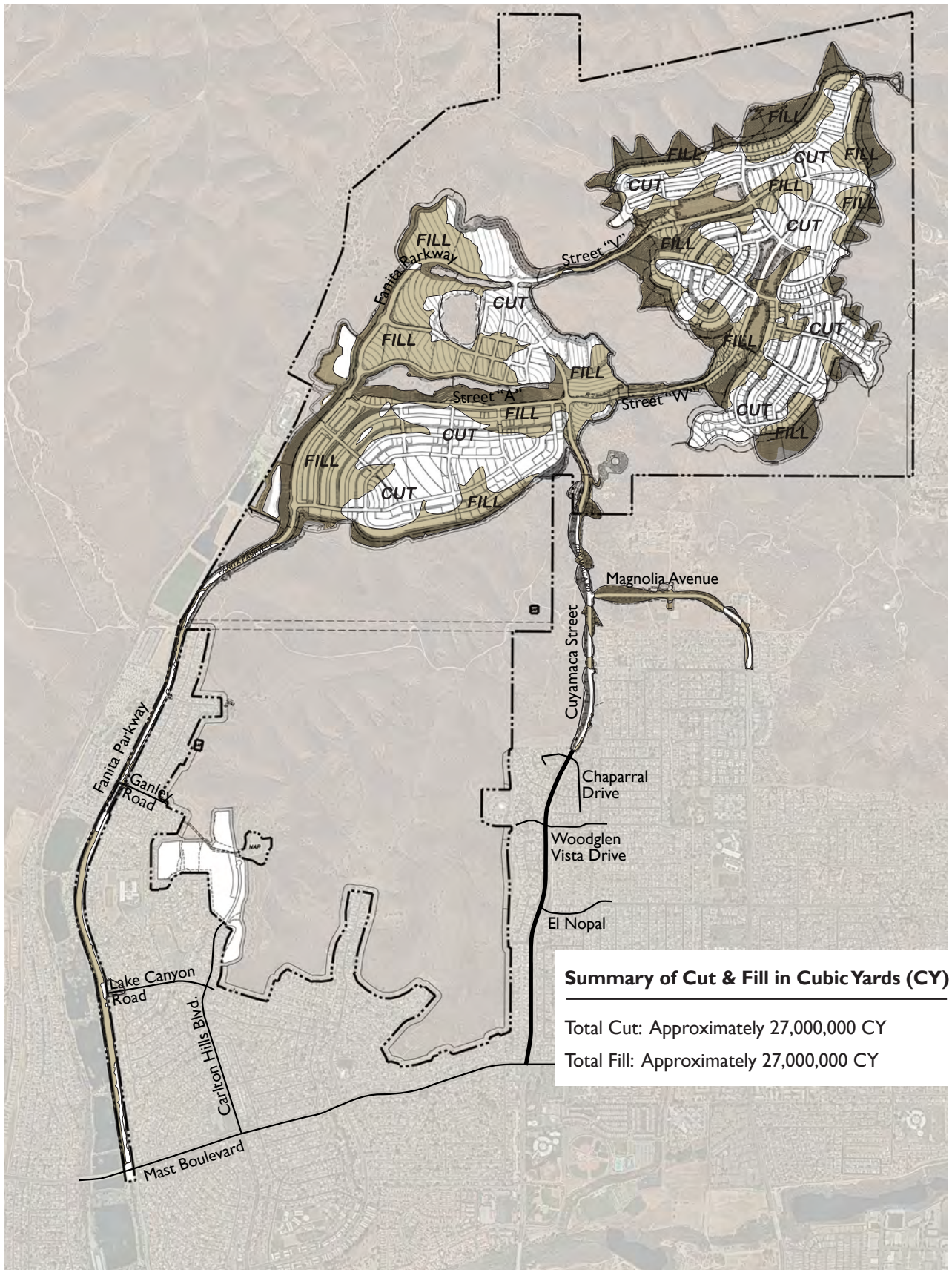




**Exhibit 8.1: Conceptual Grading Plan**

 *not to scale*





**Summary of Cut & Fill in Cubic Yards (CY)**

Total Cut: Approximately 27,000,000 CY

Total Fill: Approximately 27,000,000 CY

⊕ not to scale

**Exhibit 8.2: Conceptual Cut & Fill**

## **A. Grading Design Standards**

Except as described herein, grading within Fanita Ranch shall comply with the requirements of the City of Santee Municipal Code. The following grading design standards have been specifically provided to address the unique topography of Fanita Ranch, minimize the development footprint, and maximize the preservation of natural open space areas within the Specific Plan Area:

1. Grading within Fanita Ranch shall be as efficient as possible to minimize the development footprint.
2. Grading should not be excessive beyond that necessary for the use, access and drainage of the site.
3. Grading shall be designed to minimize adverse environmental and visual impacts to surrounding properties by blending visible edges with the surrounding topography that occurs around the perimeter of the development area. Intersecting front and side slopes shall have corners rounded with a minimum radius of 5 feet.
4. “Public Interest” slopes within the Specific Plan Area, as shown in *Exhibit 8.1: Conceptual Grading Plan*, that are visible from the public rights-of-way shall be designed to utilize land form grading techniques to recreate and mimic the natural contours and drainages.
5. Cut and fill slopes over 40 feet in height shall be identified on the Tentative Map and shall be specifically approved by the Santee City Council.
6. See “Geotechnical Investigation for Fanita Ranch” Section 8.3 for details and terrace drain recommendations and requirements (refer to Fanita Ranch EIR Appendix G1-G4).
7. Slopes exceeding 3 feet in height shall be protected by an erosion control program as soon as possible after grading.
8. A usable side yard of at least 3 feet from any building wall shall be provided where adjacent to the toe or top of a slope.
9. When placing fill slopes over steep hillsides, measures shall be taken to ensure stability, drainage and erosion control such as temporary mulching and seeding, sediment traps and basins, storm drain inlet protection and other erosion and sediment control BMPs. Grading activities shall comply with applicable provisions of the California Building Code, implement applicable BMPs listed in the City of Santee BMP Design Manual and the Guidelines for Surface Water Pollution Prevention, and incorporate grading-related project design features provided in the EIR for Fanita Ranch.

## 8.2 Drainage and Stormwater Management

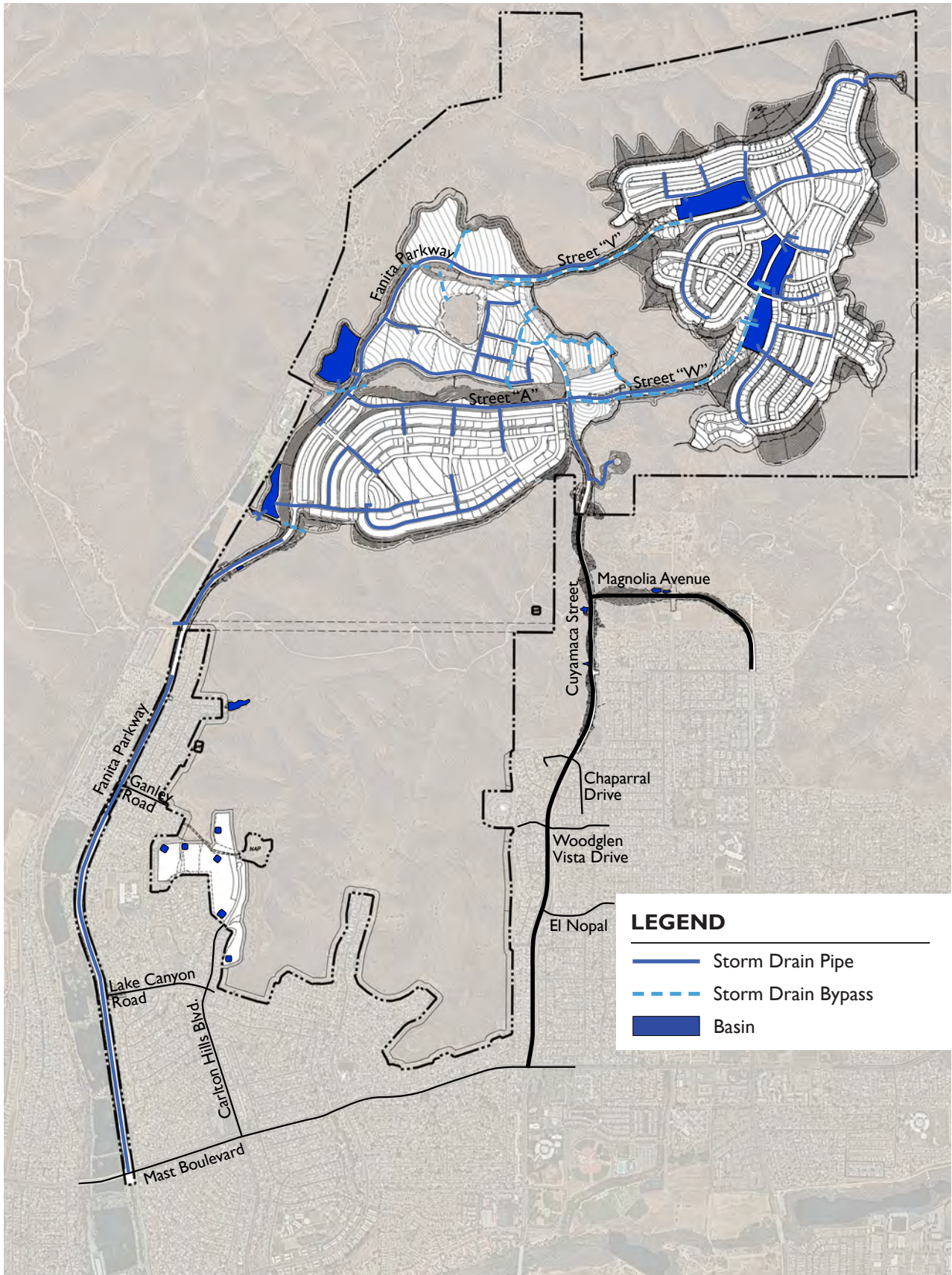
Stormwater will be collected using low impact development (LID) techniques and best management practices (BMPs) near the source to ensure that runoff from the development area is treated for pollutant removal prior to discharging into the natural watershed. All stormwater will be treated in compliance with the applicable San Diego Regional Water Quality Control Board requirements.

The system will collect stormwater through a series of swales, catch basins and culverts that direct stormwater to hydromodification/water quality basins as illustrated in *Exhibit 8.3: Conceptual Storm Drain Plan*. This system will allow biofiltration, evapotranspiration and filtering of the stormwater to remove microscopic organisms, suspended solids, organic material, nitrogen and phosphorous. Treated stormwater from basins will drain into Sycamore Creek, then to the San Diego River.

Hydromodification allows water to be released into the Sycamore Creek and tributary watersheds at a rate that is consistent with existing natural flows. Energy dissipaters will be used where necessary to reduce the velocity of the stormwater discharges and minimize erosion. All stormwater flows will be released in compliance with the City of Santee BMP Design Manual dated February 2016.

Green Street principles and infrastructure are proposed for meeting water quality requirements for portions of Fanita Parkway, Cuyamaca Street, Carlton Hills Boulevard and Magnolia Avenue off-site where the roadways are proposed to be reconstructed or retrofitted. The Green Street approach integrates strategies into roadway design that help protect, restore, and mimic the natural water cycle such that runoff is encouraged to be percolated and/or stored in a more natural manner.





**Exhibit 8.3: Conceptual Storm Drainage Plan**

⊕ not to scale

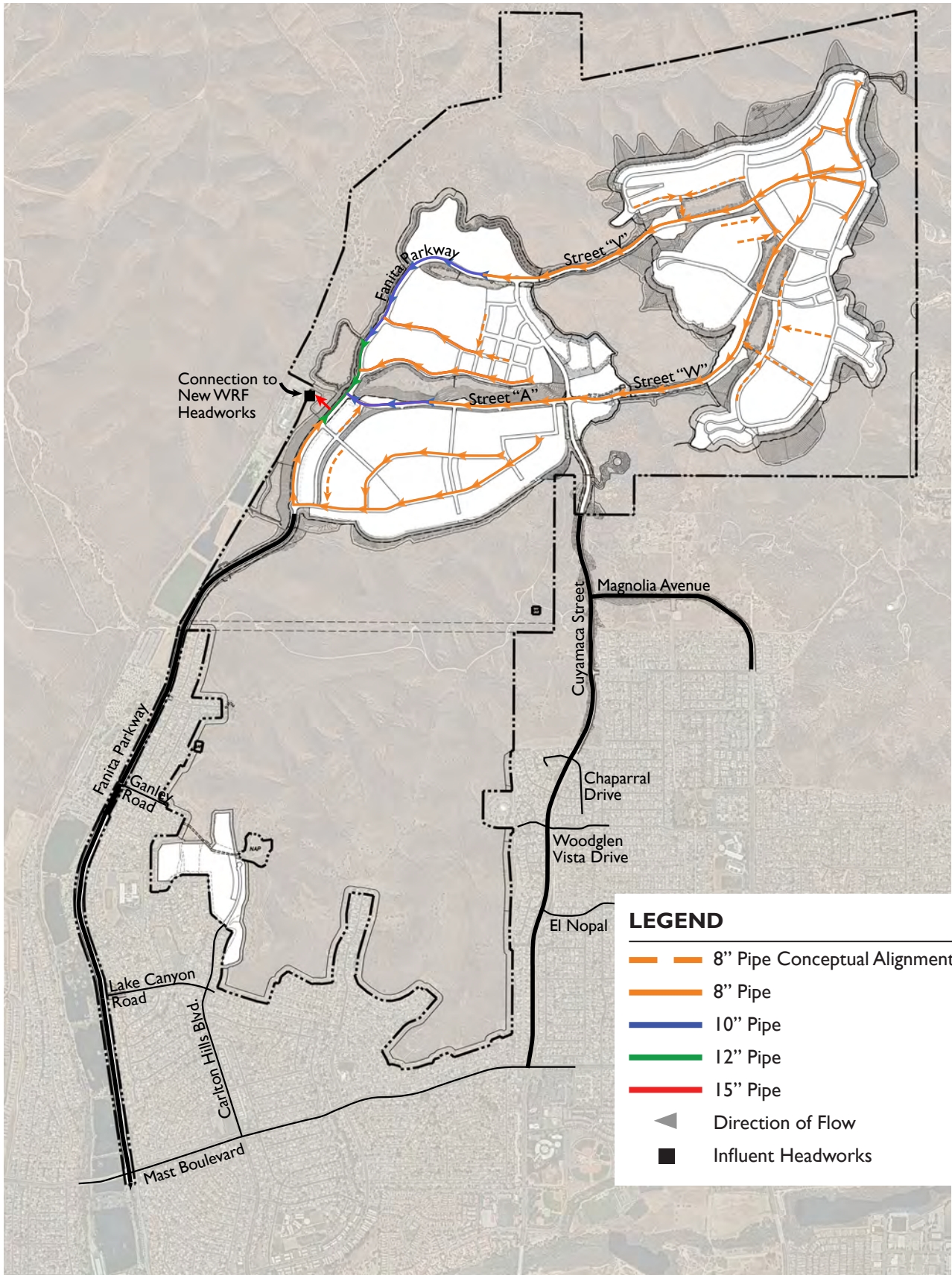
## 8.3 Sewer

Padre Dam Municipal Water District (PDMWD) will provide sewer services for Fanita Ranch. A new gravity sewer system, consisting of 8-inch to 12-inch pipes, is proposed on-site to collect and convey wastewater to a 15-inch trunk sewer at the western edge of Orchard Village, as shown in *Exhibit 8.4: Conceptual Sanitary Sewer Plan*.

Sewer lines that are installed at greater than a 10% gradient will require lined manholes and odor control measures. Sewer lines installed at a gradient of greater than 15% will require special review and approval from the PDMWD Director of Engineering. Sewer mains shall not be installed at a depth greater than 14 feet without approval by PDMWD. Where pipelines are installed outside of the public right-of-way, easements will be required in accordance with PDMWD standards.

Ultimately, the wastewater will be conveyed by a gravity system west of Orchard Village through a 15-inch diameter pipe to a headworks facility that provides screening and grit removal specifically for Fanita Ranch's sanitary flows. In addition, Fanita Ranch must provide a gravity connection to existing 18-inch and 24-inch Metro System lines that connect the Ray Stoyer Water Recycling Facility (WRF) to the Metro System. The design of the headworks will meet PDMWD requirements, including redundant pumping units, screening/grinding of influent, backup power and telemetry. Fanita Ranch will be required to dedicate land for the headworks site to PDMWD. The Padre Dam Treatment Plant has adequate capacity to serve the Specific Plan Area.





**Exhibit 8.4: Conceptual Sanitary Sewer Plan**

⊕ *not to scale*

## 8.4 Water

PDMWD will provide domestic water service to the Specific Plan Area. A new domestic water system consisting of transmission and distribution pipes, two reservoirs and two pump stations will distribute potable water throughout the Specific Plan Area. Water from the Carlton Hills Reservoir and Cuyamaca Reservoir will provide water for Fanita Ranch.

Fanita Ranch falls within three water pressure zones as shown in *Exhibit 8.5: Conceptual Water Plan*. Water will be conveyed from the 880 Zone by connecting to the existing system in Cuyamaca Street and Magnolia Avenue and extending a new transmission line in Cuyamaca Street to the Specific Plan Area. A redundant feed of 880 Zone water to the Specific Plan Area will be formed by connecting to the existing 629 Zone near the Carlton Hills Reservoir and constructing an 880 Zone pump station to pump water through a transmission line in Fanita Parkway to the Specific Plan Area. The 880 Zone supplies to the Specific Plan Area will feed a proposed onsite 880 Zone reservoir that is planned to the south of Street “W” and east of Cuyamaca Street.

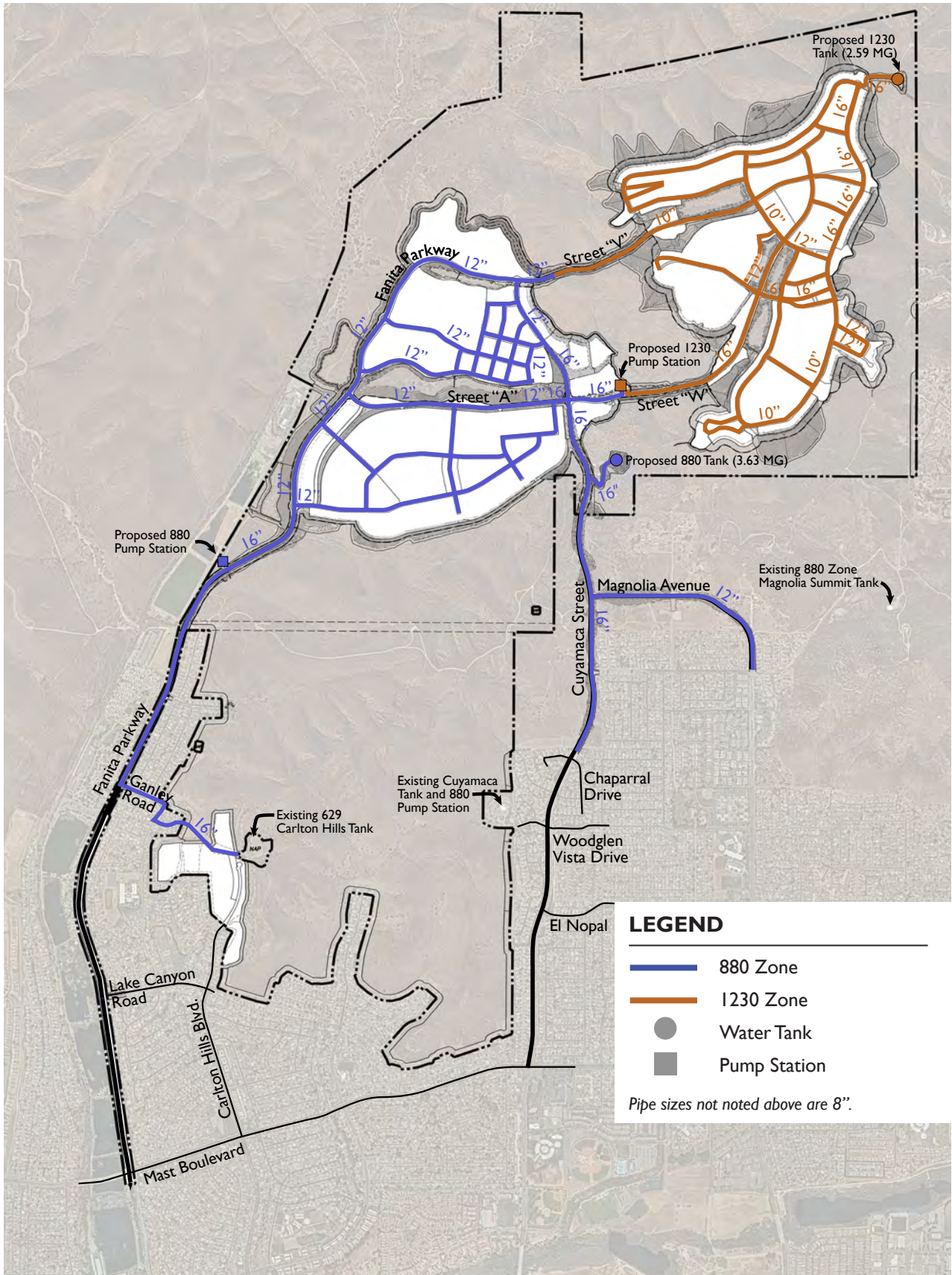
A 1230 Zone pump station will be located to the north of the 880 Zone water reservoir. This second pump station will convey water to an onsite 1230 Zone reservoir with a capacity that serves the upper portions of Fanita Ranch. The lots located in the vicinity of the R-13 planning area (shown in *Exhibit 3.2: Site Utilization Plan*) will receive adequate fire protection service from the 1230 Zone system, but will also have private individual pumps to boost additional domestic service pressure. Masonry walls will be installed at the pump stations as indicated on *Exhibit 5.18: Conceptual Wall and Fencing Plan* to provide noise attenuation.

Since PDMWD has an existing 880 Zone reservoir in the system, the new proposed 880 Zone reservoir will consist of a single storage reservoir. Since the 1230 Zone will be formed by constructing new 1230 Zone reservoir, this storage will either require two reservoirs at this site or a single reservoir with two storage bays, or “tank in a tank” type design. The proposed 880 Zone and 1230 Zone reservoirs will be sized to accommodate the operational and fire flow storage needs for their respective service areas.

Fanita Ranch will require a redundant or looped water supply for fire protection and system reliability. Water mains will be installed in Fanita Parkway and Cuyamaca Street and shall be looped through the Villages to provide adequate domestic and fire flow service in the event of a disruption of water supply from one of the mains. In addition, redundant or looped water supply will provide additional fire flow in the event of a large water demand fire.

The water system for Fanita Ranch shall provide 2,500 gallons per minute for 2 hours fire flow with fire hydrants spaced every 300 feet on average. The water system shall be designed and installed per Padre Dam Water District and Santee Fire Department requirements.





**Exhibit 8.5: Conceptual Water Plan**

⊕ not to scale

The sizing of transmission lines, reservoirs and pump stations have been estimated on *Exhibit 8.5: Conceptual Water Plan*; however, the final sizing of these facilities will be determined by a water and sewer study being performed by PDMWD.

New buildings will be designed with the latest water efficient plumbing systems, fixtures and faucets. Native and drought tolerant landscaping will reduce the demand for irrigation water. Turf will be limited to active play areas. Where irrigation is needed, Advanced Treated Water provided by PDMWD will be used. Irrigation systems will use smart controllers to automatically adjust the amount and frequency of water based on current weather and soil conditions.

Mulching, hydrozoning and other water-conserving planting and maintenance techniques will be implemented in all common area and park landscaping. These techniques and water-wise education will be taught as part of a community education program at the Farm or elsewhere in Fanita Commons.

#### **8.4.1 Recycled Water/Advanced Treated Water**

PDMWD provides recycled water service for the Cities of Santee, El Cajon and Lakeside. PDMWD has historically planned for the expansion of its recycled water system, including the construction of facilities within Fanita Ranch; however, PDMWD is actively engaged in the planning and development of the proposed East County Advanced Water Purification (ECAWP) Program. PDMWD may provide recycled water to Fanita Ranch for construction purposes on a limited and seasonal basis, but PDMWD will not pursue expansion of their permanent recycled water system to serve Fanita Ranch or other future developments within the District.

Fanita Ranch will utilize water from the ECAWP Program. The majority of East San Diego County's water supply is imported from the Sacramento-San Joaquin River Delta and the Colorado River requiring hundreds of miles of transport and pumping. The result is high energy consumption, increased greenhouse gas emissions, and impacts to sensitive habitats. In recent years, California has experienced severe droughts which have made the availability of water uncertain, unreliable and expensive.

The ECAWP Program is anticipated to create a continuous localized, sustainable and drought-resilient potable water supply. Wastewater collected from throughout the District is treated at the Ray Stoyer WRF, which treats 2 million gallons of wastewater a day. This facility will use state-of-the art technology that involves four highly advanced water treatment steps:

1. Free Chlorine disinfection: Water is disinfected, making any viruses harmless.
2. Membrane Filtration: High pressure pushes water through filters with microscopic holes to filter out particles that are 300 times smaller than a human hair.

3. Reverse Osmosis: This process, which is also used to desalinate ocean water, compresses water between two membranes to filter out particles 100 times smaller than a human hair and 100 times smaller than a virus. It also removes salt, pharmaceuticals, and chemicals so that the resulting water is nearly distilled.
4. Advanced Oxidation: This process, which is also used to sterilize surgical instruments and baby food jars, exposes the water to UV light and hydrogen peroxide to sterilize and purify water to high State and Federal drinking water standards.

The purified water will be returned to Lake Jennings and aquifers for storage. The stored water is then treated one more time before being distributed through the potable water system. This new source of water will produce up to 30 percent of East County's current drinking water demands.

Advanced Treated Water offers a more cost-effective and efficient alternative to recycled water, which requires dual piping and has limited applications. Advanced Treated Water also has the advantage over recycled water in that it can be supplied in proportion to demand, whereas recycled water continues to be generated during wet weather and must be stored or disposed of. Because the Advance Treated Water is treated to drinking water standards, it can be used for any purpose and no additional pipes or facilities are required since water can be distributed through the domestic water system. This technology results in a reliable, new supply of water within Fanita Ranch and throughout the region and reduces the region's dependency on outside water sources. It also conserves energy, reduces greenhouse gas emissions, decreases discharge into oceans and lessens impacts to sensitive habitats.

#### **8.4.2 Water Conservation**

The landscape palettes provided in *Chapter 5: Landscape Architecture, Community Design & Outdoor Lighting Design Plan*, consisting of native and drought tolerant landscape palettes, are consistent with Chapter 13.36 "Landscape and Irrigation Regulations" of the SMC and the California Model Water Efficient Landscape Ordinance (MWELO). In addition, all new development is subject to CALGreen, which includes requirements for low flow toilets and fixtures, water efficient appliances, and water efficient irrigation. Builders are encouraged to exceed code requirements by pursuing CALGreen's voluntary measures regarding water conservation.

### **8.5 Dry Utilities**

San Diego Gas & Electric Company (SDG&E) provides electricity and natural gas for San Diego County including Santee. These utilities will be extended into Fanita Ranch from existing local distribution systems in the region. A pre-existing SDG&E electrical transmission easement traverses east to west through the Habitat Preserve within the Specific Plan Area. New electric and natural gas facilities will be installed in joint utility trenches within the public street rights-of-way as required by the City of Santee.



In conjunction with gas and electric facilities, telephone and cable television/internet facilities also will be constructed.

The Specific Plan includes sustainability features that promote energy conservation, renewable energy and climate protection, consistent with the City's Sustainable Santee Plan. A summary of the key sustainability features is provided in *Section 9.5: Smart Growth & Sustainable Community*.

## 8.6 Fire Protection

Fanita Ranch is located in a very high fire hazard severity zone. Due to its hillside location and surrounding natural open space areas, Fanita Ranch has been designed to incorporate a variety of design features aimed at reducing the risk of fire. The Fanita Ranch Fire Protection Plan (FPP), Wildland Evacuation Plan and Fanita Ranch Construction Fire Protection Plan (CFPP) establish comprehensive fire protection through a system of fire safety features and design measures that have proven to perform well in wildland/urban interface and very high fire hazard severity zones. The system of fire protection includes a redundant layering of measures so that no single feature is relied upon for protection.

Fanita Ranch includes at least two ingress-egress points that will connect to three arterial roads and adequately sized internal streets that allow traffic circulation and emergency response to all portions of the development areas. Fanita Ranch includes water pressure and fire flow consistent with code requirements and provides fire hydrants throughout the community. The community trails and pathways will be accessible for emergency access at numerous locations within the community. The open space trail network will be accessible via trail access points located along the perimeter of the development area.

### 8.6.1 Fire Station

Fire service would be provided by the Santee Fire Department (SFD). The anticipated project population and number of calculated emergency calls would affect the response capabilities of SFD's nearest existing stations. Additionally, the calls from the community would not be responded to within the City's response time goals from existing stations. As such, Fanita Ranch would include a SFD-approved, on-site station upon first occupancy that is capable of responding to all of the project's buildable lots within the City's General Plan six-minute overall response time standard (four-minute travel time). Additionally, the off-site effective fire fighting force (3 engines, 14 firefighters, and battalion chief) can be on site within eight minutes, consistent with National Fire Protection Association (NFPA) 1710 Standard.



## 8.6.2 Fire Protection Plan

The FPP (see Fanita Ranch EIR Appendix P1) identifies the fire risk associated with Fanita Ranch's planned land uses, as well as requirements for fuel modification, building design, construction and other pertinent development infrastructure criteria for fire protection. The primary focus of the FPP is providing an implementable framework for suitable protection of the planned structures and the people living and using them. Tasks completed in the preparation of the FPP include data review, code review, site fire risk analysis, land use plan review, fire behavior modeling and review of a previous site FPP. The following project features are required and form the basis of the system of protection necessary to minimize structural ignitions and facilitate access by emergency responders:

- Application of the latest adopted ignition resistant building codes;
- Non-combustible or ignition resistant exterior wall coverings;
- Multi-pane glazing with a minimum of one tempered pane;
- Ember resistant vents;
- Interior, automatic fire sprinklers for all new structures;
- Modern infrastructure, access roads and water delivery systems;
- Maintained fuel modification areas; and
- Fire apparatus access roads throughout Fanita Ranch.

### 8.6.2.1 Fuel Modification Zones

An important component of a fire protection system is the provision for ignition resistant landscapes and modified vegetation buffers. Fuel modification for Fanita Ranch is proposed for the entire exterior perimeter, along roadways and interior landscaped areas adjacent to natural open space. Fuel modification in Fanita Ranch is governed by the Fanita Ranch FPP. Below is a summary description of residential lot FMZs. Detailed information on the cross sections, plant selections, maintenance and management of the FMZs and other vegetation management areas is provided in the FPP.

At Fanita Ranch, some residential lots located adjacent to natural open space around the perimeter of the development have a different configuration than interior lots. For these perimeter lots, the rear property lines are located 50 feet from the top or toe of the slope at the back of the building pad. The property owner will manage and maintain the first 15 feet of the slope and the HOA will have a maintenance easement over the next 35 feet of the slope. A tubular steel boundary fence will mark the limit between homeowner-maintained and HOA-maintained landscaping.

- **Zone 1A – Setback Zone (minimum 15 feet wide):** Zone 1A is the first 15 feet or more of the rear or side yard from the furthest projection of the structure (e.g. the outer edge of the eave) to the top or toe of the slope for any structure that is adjacent to natural open space. This area will consist of low fuel density, ignition resistant landscaping including hardscape, turf and permanently irrigated and maintained landscaping. This area will be planted with drought-tolerant, less flammable plants

from the FPP's Plant Palettes. Building restrictions apply within this area pursuant to the FPP. Zone 1A will be maintained by the property owner. No California Rooms, permanent or portable fire pits, outdoor fireplaces, or flame-generating devices that burn wood are allowed within Zone 1A. Fencing within all lots that are directly adjacent to open space or naturally vegetated areas shall be constructed with non-combustible materials (stone, block, fire-rated wood, treated vinyl, etc.) or materials approved by the Santee Fire Department. Property owners will be responsible for ensuring that rear or side yard landscaping is maintained for annual inspection as required by the FPP.

- **Zone 1B – Irrigated Zone (minimum 15 feet wide), Where Required:** Zone 1B will be 15 feet wide, starting at the outer edge of Zone 1A (top or toe of slope) and moving outward towards Zone 1C to a tubular steel boundary fence. This fuel modification area will be planted with drought-tolerant, less flammable plant species from the FPP's Plant Palettes. Vegetation in this area shall be kept in a well-irrigated condition and cleared of dead materials. Trees are allowed in this area if placed and trimmed as specified in the FPP. Zone 1B will be a property owner managed and maintained area. All structures, including fencing, decks, arbors, etc. will require approval by the Santee Fire Department. Property owners will be responsible for ensuring that Zone 1B landscaping is maintained for annual inspection.
- **Zone 1C – Irrigated Zone (minimum 35 feet wide/50 feet wide if no Zone 1B):** The standard Zone 1C will be 35 feet wide, starting at the Zone 1B boundary fence and moving outward to Zone 2. Where the property line is located at the top or toe of the slope at the back edge of the building pad and there is no Zone 1B, Zone 1C will be 50 feet wide. This fuel modification area will be planted with drought-tolerant, less flammable plant species from the FPP's Plant Palettes. Vegetation in this area shall be kept in a well-irrigated condition and cleared of dead materials. Trees are allowed in this area if placed and trimmed as specified in the FPP. Zone 1C requires year-round maintenance by the HOA.
- **Zone 2 – Retain 30% of Vegetation (50 to 100 feet wide):** Zone 2 adjoins Zone 1C on its outer edge and measures 50 to 100 feet in width. In this Zone, no more than 30% of the native, non-irrigated vegetation will be retained. Plants for revegetation shall consist of species found on the FPP's Plant Palettes. No plant listed in the FPP's Prohibited List shall be planted or remain in Zone 2. This area requires inspection and periodic maintenance by the HOA.

#### 8.6.2.2 Other Vegetation Management

Vegetation maintenance and management and fire safety measures for the vegetation management areas listed below shall be in accordance with the provisions included in the FPP:

- Fuel Modification Zones for Existing Communities
- Special Use Area Fuel Modification Zones

- Roadside Fuel Modification Zones
- Farmland – Row Crops, Orchards or Vineyards
- Parks and Greenways
- Trail Vegetation Management
- Additional Tree Planting and Maintenance
- San Diego Gas and Electric Easement
- Water Detention/Treatment Basins
- Interior Manufactured Slopes
- Environmentally Sensitive Areas/Open Space/Riparian Areas
- Vacant Parcels and Lots
- Private Lots

### **8.6.2.3 Fuel Modification Maintenance and Compliance Inspection**

Vegetation management will be completed annually as determined by the Santee Fire Department. Homeowners and private lot owners will be responsible for all vegetation management on their lots in compliance with the FPP. An approved maintenance entity will perform FMZ maintenance in all Villages and community FMZs. The HOA will be responsible for long-term funding and ongoing compliance with all provisions of the FPP. The HOA for Fanita Ranch will obtain an FMZ inspection and report from a qualified 3rd party inspector approved by the Santee Fire Department in May and September of each year certifying that vegetation management activities throughout Fanita Ranch have been performed pursuant to the FPP.

### **8.6.3 Wildland Evacuation Plan**

The Fanita Ranch Wildland Evacuation Plan (WEP) (Fanita Ranch EIR, Appendix P2) focuses on resident awareness and preparedness. The WEP provides an evacuation route map along with family evacuation preparation tools that will result in faster evacuations and a populace that understands the potential wildfire threat and actions they may be directed to take. Fanita Ranch includes at least two ingress-egress points that will connect to three arterial roads and adequately sized internal streets that allow traffic circulation and emergency response to all portions of the development areas as well as required evacuation routes.

Fanita Ranch will implement a community outreach and education program to ensure that residents and visitors will be fire-aware, have regular reminders of fire safety practices and be encouraged to sign up for Reverse 911. Residents will also be encouraged to prepare personal action plans following the “Ready, Set, Go!” evacuation model.

### **8.6.4 Construction Fire Protection Plan**

The Fanita Ranch Construction Fire Prevention Plan (CFPP) (Fanita Ranch EIR Appendix P1) provides basic direction for fire safety awareness on the Fanita Ranch project site during construction. CFPPs do not anticipate every potential fire scenario that may occur during construction but attempt to educate site personnel to the very real danger associated with fire ignitions. Fire ignitions can, if they involve site or off-site vegetation under certain weather conditions, develop into large scale wildfires that burn many acres and can threaten public and private assets. Therefore, the CFPP provides standard protocols and approaches, including Red Flag Warning weather restrictions, for reducing the potential of ignitions for typical construction site activities. When employed, the concepts discussed in the CFPP will help minimize and avoid ignitions, as well as extinguish any ignitions while they are small and controllable.

Vegetation management requirements will be implemented at construction commencement and throughout the construction phase. Vegetation management will be performed pursuant to the FPP and the Santee Fire Department requirements on all building locations prior to the start of work and prior to any import of combustible construction materials. Adequate fuel breaks, as approved by Santee Fire Department, will be created around all grading, site work and other construction activities in areas where there is flammable vegetation. Fuel breaks will range between 50 and 150 feet around grading activities.

## **8.7 Law Enforcement**

Law enforcement services will be provided by the San Diego County Sheriff's Department (SDCSD) through an existing contract with the City of Santee. The Sheriff operates two facilities in Santee. The primary department offices are located at 8811 Cuyamaca Street and a storefront facility is located in the Santee Trolley Square Center. The Village Center land use designation permits a law enforcement substation within Fanita Commons for future expansion of law enforcement services if necessary.

## **8.8 Solid Waste and Recycling**

### **8.8.1 Solid Waste and Recycling**

Commercial and residential trash hauling, as well as industrial solid waste, green waste and recycling collection and disposal services are provided by Waste Management Inc. under a contractual franchise agreement with the City of Santee. Waste Management provides trash, recycling and yard waste pickup services on a weekly basis for residential customers and up to seven times per week for business customers. Santee homeowners are eligible for two free passes per year to dispose of bulky items, concrete, or up to one ton of other forms of solid waste at the Sycamore Landfill. Nonresidential development and attached residential development (except as noted herein) in Fanita Ranch shall comply with the trash enclosure requirements provided in *Section 3.2.11.7: Trash Enclosures* of the



Specific Plan. Detached residential development and attached residential development where private garages are attached to individual units will participate in the Waste Management's residential curbside pickup program. Solid waste containers for these dwellings, which will be stored in private side or rear yards or garages, will be picked up from the street curbside or private residential driveway edge on collection days.

A private company operates the 349-acre Sycamore Landfill (permit number 37-AA-0023) just outside the western City limits at 8514 Mast Boulevard at West Hills Parkway. The landfill's ultimate capacity is listed as 71 million cubic yards, with an estimated remaining capacity of 39 million cubic yards. It is estimated to continue in operation as an active disposal site until at least 2042. The final use of the landfill site after closure has not been decided.

Waste and recycling, including construction waste and recycling, will comply with CALGreen and current regulations, as may be amended from time to time, designed to divert waste from landfills.

### **8.8.2 Material Conservation and Waste Reduction**

Proposed development within the Specific Plan Area contemplates the use and reuse of onsite rock materials such as large boulders, rock cobble, decomposed granite and processed rock.

Prior to the mass grading operation, large boulders destined for reuse would be identified and moved to a staging area. During the grading operation these boulders would be placed at strategic and aesthetically pleasing locations within the development area.

There are large quantities of rock cobble existing onsite. Rock cobble will be collected and used in the construction of water quality and landscape features. It is also anticipated that a rock crushing operation would be permitted and set up onsite during construction. The rock crushing operation will produce roadway sub-base and other aggregate materials for use onsite.

In addition to rock materials, there are large deposits of decomposed granite onsite, which will be used onsite for certain trail and other landscape related purposes.

Utilization of these onsite materials eliminates the need for importing rough or finished materials thus reducing construction related vehicle emissions in support of the Sustainable Santee Plan.

The guidelines provided in *Chapter 6: Architectural Design Guidelines* include recommendations for efficient home designs that can potentially reduce the amount of lumber and other building materials needed. Strategies include simple massing forms and efficient framing techniques, use of rapidly renewable resources, and installation of durable material that require less frequent replacement.

Recycling will meet state-wide mandates that require significant recycling effort during and after construction. In addition, the Farm may offer composting and recycling facilities for residents and encourage residents to compost and recycle at home through various educational programs.

## 8.9 Education

The School land use overlay reserves a site for a potential school or other educational uses. If pursued by the Santee School District, the site could accommodate a K-8 school for up to 700 students, including new students generated by development of the Specific Plan Area. High school students in Fanita Ranch are anticipated to attend existing Santee schools in the Grossmont Union High School District.

The school site is located adjacent to the Community Park, Village Center and a neighborhood park to further establish Fanita Commons as the heart of Fanita Ranch. Strong visual and physical connections should be established between the school site and these adjacent uses through careful placement of buildings and other school open spaces to support interaction and synergy.

If the site is not acquired for a public or private school use within two years of approval of the final map for the phase in which the site is located, the site may be developed consistent with the underlying Medium Density Residential land use designation as described in *Section 3.2.5: School (S) Overlay*, subject to the density transfer requirements set forth in *Section 10.7.1: Administrative Amendments (Minor Modifications)*.

*Intentionally Blank*

# Chapter 9: Open Space, Conservation & Sustainability

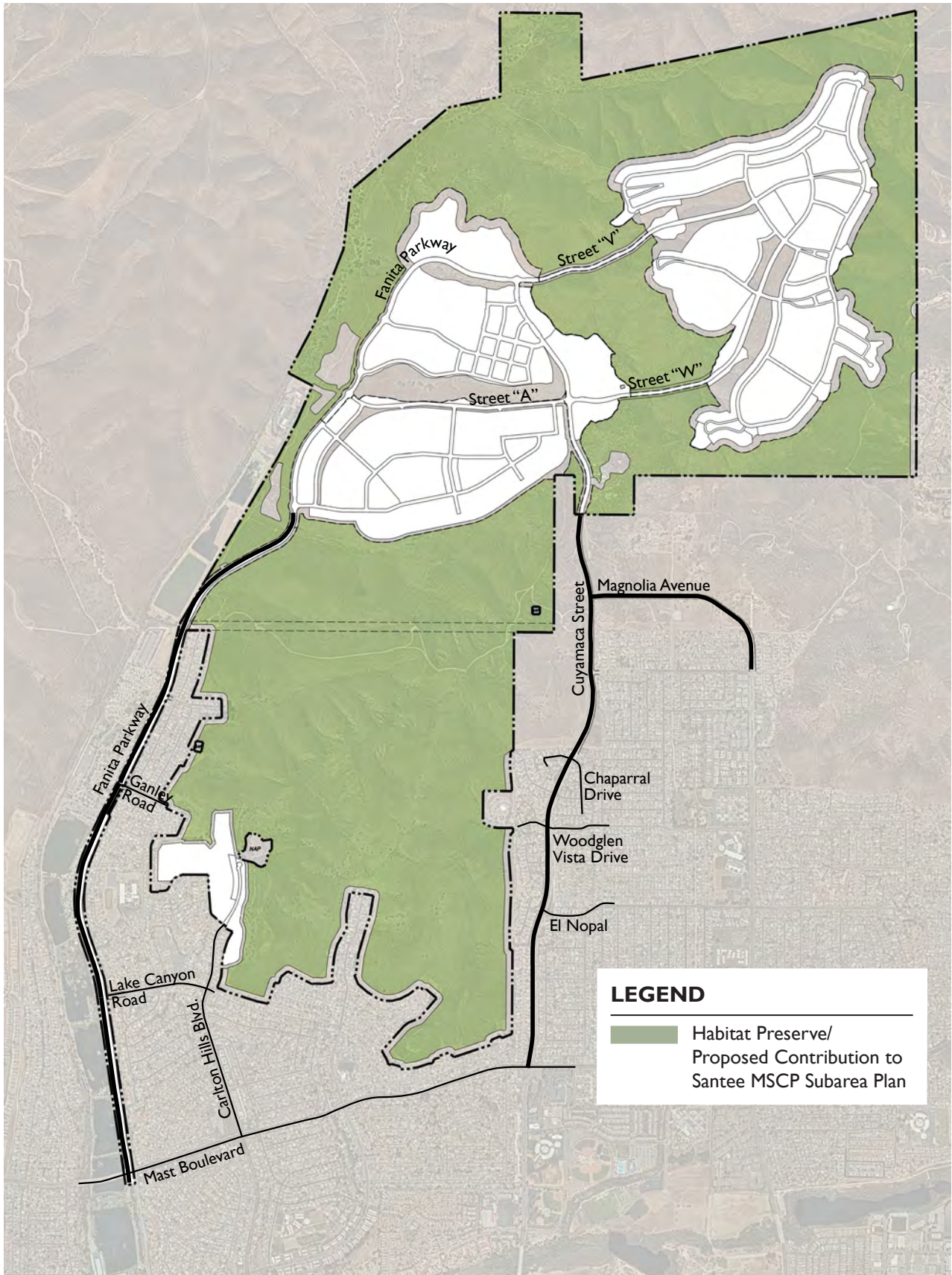
## 9.1 Conservation Overview

Conservation of natural resources is a key component of Smart Growth. In Fanita Ranch, conservation efforts will be made at multiple levels:

- A. Conservation, restoration and enhancement of natural open space and associated habitats for sensitive plant and animal species through the establishment of the Habitat Preserve and restoration of riparian areas;
- B. Preservation of cultural resources;
- C. Energy conservation and climate action;
- D. Water conservation; and
- E. Material conservation, recycling and waste reduction.

A summary of the key sustainability objectives and features that describe the conservation efforts included in the Specific Plan are provided in *Section 9.5: Smart Growth & Sustainable Community*.





**Exhibit 9.1: Habitat Preserve Plan**

⊕ not to scale

## 9.2 Habitat Preserve

Fanita Ranch contains large and diverse areas of biological resources. The Specific Plan Area includes a complex system of existing dirt roads and trails, many of which are currently subject to illegal off-road vehicular traffic and unauthorized human activities that have been detrimental to these sensitive habitats. The Specific Plan Area is also within a very high fire hazard sensitivity zone. By allowing limited development, clustered into the least sensitive portions of the Specific Plan Area, Fanita Ranch's biological areas will be preserved and managed in perpetuity and protected through permanently funded management plans and funding mechanisms.

### 9.2.1 Habitat within Fanita Ranch

The Biological Resources Technical Report for Fanita Ranch (Fanita Ranch EIR Appendix D) identifies and maps existing habitats and species onsite. This mapping was used to determine the most suitable locations for development and the most valuable and prolific areas of biological diversity in the Specific Plan Area to be preserved within the Habitat Preserve.

*Exhibits 9.1: Habitat Preserve Plan* illustrates the portions of Fanita Ranch proposed to contribute to the City of Santee Multiple Species Conservation Program (MSCP) Subarea Plan. A large portion of this open space is located in the southerly portion of the Specific Plan Area. Additionally, areas between and surrounding the Villages were selected based upon the high quality of habitat and the opportunity to provide wildlife movement corridors in these locations.

Permitted uses within the Habitat Preserve, as discussed in *Chapter 3: Land Use & Development Regulations*, include utilities and utility access roads, trails, revegetated slopes and other uses consistent with the NCCP design guidelines and standards. Restoration and enhancement of native habitat will be conducted as described in *Section 5.7: Habitat Restoration Program*. Management of the Habitat Preserve will be permitted consistent with the draft MSCP and Subarea Plans.

### 9.2.2 MSCP Subarea Plan

The MSCP is a comprehensive, long-term, multi-jurisdictional habitat conservation program developed pursuant to state NCCP legislation to preserve a network of habitat and open space areas throughout the San Diego region and to protect biodiversity. The MSCP Subregional Plan identifies the potential impacts of urban growth and establishes an overarching plan for habitat avoidance, conservation and mitigation to protect "covered species" and their habitat. The City of Santee is one of 12 jurisdictions participating in the Program, which was adopted in 1997 and covers approximately 900 square miles.

Participation in the MSCP requires local jurisdictions to adopt a Subarea Plan to implement the Subregional Plan. The Subarea Plan is a policy document that establishes a framework for the conservation of covered species and their habitats that exist within the City's jurisdiction. The Subarea

Plan serves as the basis for a Section 10(a)(1)(b) Incidental “Take” Permit, which is issued by the United States Fish and Wildlife Service and a Section 2835/2081 permit issued by the California Department of Fish and Wildlife to the City of Santee. The permit issued by these federal and state wildlife agencies grants the City long-term authority to “take” identified Covered Species as defined in the Endangered Species Act and allow landowners to impact sensitive species and their habitat as approved as part of the City’s MSCP Subarea Plan. Prior to pursuing mitigation outside of the Subarea Plan Area, landowners and/or project proponents must demonstrate to the City that all mitigation options within the City have been exhausted.

### **9.2.3 Fanita Ranch Preserve Management Plan**

A Preserve Management Plan (PMP) has been prepared for the Habitat Preserve that is consistent with the NCCP design guidelines and standards. The PMP will direct the long-term management of the biological resources within the Habitat Preserve in accordance with the Preserve Management objectives provided below.

### **9.2.4 Preserve Management Objectives**

This Specific Plan establishes the following objectives for Preserve Management within Fanita Ranch:

- A. Designate biologically sensitive and diverse areas within Fanita Ranch as Habitat Preserve for inclusion in the City of Santee MSCP Subarea Plan.
- B. Ensure the long-term viability and sustainability of native ecosystems within Fanita Ranch through long-term funded open space management.
- C. Implement the NCCP design guidelines and standards, including conservation and enhancement of sensitive habitats and species, promotion of healthy biodiversity and allowing managed passive recreation uses such as trails.
- D. Provide carefully planned and managed public access to the Habitat Preserve to allow residents and visitors to enjoy the scenic qualities of Fanita Ranch, connect with nature and learn about and appreciate the Specific Plan Area’s biodiversity.
- E. Restore and enhance native plant and animal communities in key locations to support long-term propagation of viable populations of sensitive plant and animal species.
- F. Close existing informally established and potentially harmful trails and provide revegetation in those areas.



- G. Maintain viable wildlife corridors through the Specific Plan Area and provide wildlife corridor connections to adjoining open space habitat areas in order to maintain large-scale wildlife movement.
- H. Develop a management strategy to enhance and protect sensitive species, habitats, wildlife corridors and linkages to ensure they remain functional and healthy.

### **9.2.5 Preserve Management Plan Strategies**

A Preserve Management Plan has been prepared for the Habitat Preserve that is consistent with the NCCP design guidelines and standards and implements the following strategies:

- A. Identify key habitats, species, and wildlife corridors within the preserve.
- B. Develop a habitat restoration and enhancement plan that includes recommendations for short-term and long-term preserve management designed to maximize the success of conservation efforts.
- C. Provide strategies and prescriptions to manage key habitats, species and wildlife corridors for the long-term protection of these areas.
- D. Strategically locate and design trails to utilize existing trails and dirt roadways to avoid existing sensitive habitats and create passive and intentional recreational amenities for the public. Manage trails in a manner that supports the long-term viability of sensitive species.

## **9.3 Open Space**

The Specific Plan Area includes 256 acres of open space areas outside of the Habitat Preserve, which consist of two riparian areas in Fanita Commons, brush management areas at the edge of development, slopes adjacent to streets and within Villages, trailheads and water quality basins that will be maintained and managed by the Homeowners Association, and open space land for water tanks and pump stations that will be dedicated to and maintained by Padre Dam Municipal Water District (PDMWD).

The Fanita Ranch project will implement a habitat restoration and enhancement program that will offset impacts to existing biological resources located within the development footprint and generally increase the integrity of ecological systems across the property. Restoration activities will occur in upland and wetland-riparian areas that increase native habitat, which will benefit sensitive species and wildlife in general. Manufactured slopes on the exterior of the development footprint will be revegetated to blend with the adjacent landscape.



Brush management areas and the habitat restoration program are described in greater detail in *Chapter 5: Landscape Architecture, Community Design & Outdoor Lighting Design Plan* and *Chapter 8: Grading, Utilities & Services*. These open space areas are subject to the provisions set forth in the Fanita Ranch Fire Protection Plan (see Fanita Ranch EIR Appendix P1).

## 9.4 Cultural Resource Protection

A significant number of cultural resources are present in the Specific Plan Area. A Phase I intensive survey and report was completed to determine the presence or absence of archaeological features within the Specific Plan Area where proposed development or activity could have a potential effect. The survey included archival research of California Historical Resource Information System (CHRIS), a Sacred Lands File search, contacting local tribes, reviewing historical aerial photographs and maps, and a pedestrian survey. See the EIR prepared for Fanita Ranch for additional information.

## 9.5 Smart Growth and Sustainable Community

Smart growth is a planning paradigm that advocates thoughtful and sustainable development patterns and avoids urban sprawl to conserve resources, reduce impacts, promote alternatives to single occupancy vehicle use, support livability, offer opportunities for social engagement and achieve fiscal sustainability. In 2015, the San Diego Association of Governments (SANDAG) adopted “San Diego Forward, The Regional Plan,” which combines the big-picture vision for how the San Diego region will grow over the next 35 years with an implementation program to help make that vision a reality. The Regional Plan calls for integrated coordination between land use and transportation and includes a Smart Growth Concept Map that identifies locations in the region that can support smart growth, transit, walking and biking.

Fanita Ranch embraces the smart growth paradigm by applying these smart growth principles comprehensively throughout the Specific Plan Area to create a compact, vibrant, walkable and mixed-use community and preserve large, contiguous open space as Habitat Preserve to ensure long-term protection of sensitive species and habitats. New development will be sustainably designed to conform to the State of California’s goals for greenhouse gas reduction, conserve water and energy and provide sustainable buildings, which in turn will reduce impacts on the environment, enhance the quality of life and encourage a healthy lifestyle for the Fanita Ranch residents.

Sustainability is an integral part of the design vision for Fanita Ranch. The following is a summary of the key Specific Plan sustainability objectives and features that may be implemented within Fanita Ranch, including some that are now or may become mandatory with future updates to CALGreen or other applicable provisions of law. All sustainability features that are required at the time of construction will be implemented during the development of Fanita Ranch.

## 9.5.1 Open Space Conservation

### A. Open Space Conservation Objective

Conserve natural open space and protect sensitive biological and cultural resources

### B. Open Space Conservation Features

1. Cluster development areas to establish large, contiguous open space as the Habitat Preserve for dedication to the City of Santee MSCP Subarea Plan to ensure long-term protection of sensitive species and habitats.
2. Implement a Preserve Management Plan for the Habitat Preserve that is consistent with the NCCP design guidelines and standards.
3. Implement a Habitat Restoration Program that restores a variety of native upland vegetation communities within the open space areas and Habitat Preserve, increasing the integrity of ecological system across the Specific Plan Area.
4. Preserve wildlife corridors within the Habitat Preserve.
5. Protect sensitive cultural resources.

## 9.5.2 Land Use, Transportation and Community Design

### A. Land Use, Transportation and Community Design Objectives

1. Integrate land use and transportation planning to decrease reliance on vehicle use and reduce greenhouse gas emissions.
2. Provide a highly connected Complete Streets system that optimizes various modes of transportation to reduce fuel consumption while addressing functionality, aesthetics and safety.
3. Implement an extensive trail system available for use by the public that connects all neighborhoods to the Habitat Preserve and various destinations within Fanita Ranch, ensuring a walkable community to help minimize vehicular use and encourage interaction with the natural environment.

## **B. Land Use, Transportation and Community Design Features**

1. Provide diverse housing types and sizes to accommodate people of different age groups, incomes, household types and abilities.
2. Locate parks and recreation amenities within easy walking distance of each home.
3. Implement an efficient, Complete Streets network with multiple routes to distribute traffic and encourage walking, biking and low speed vehicle use and increase destination accessibility.
4. Provide a street system of varying design capacities tailored to meet the unique Village concept and site constraints.
5. Incorporate traffic calming measures that reduce traffic speeds and enhance safety for pedestrians and cyclists.
6. Provide a pedestrian and bicycle mobility system consisting of sidewalks, trails and bikeways throughout Fanita Ranch, providing linkages between neighborhoods to other key land uses.
7. Reduce parking footprint through shared parking and structured parking.
8. Encourage bicycle parking and support facilities such as bike lockers, repair stations and rentals, education programs and events.
9. Provide Neighborhood Electric Vehicle (NEV) safe routes and designated parking, drop-off areas and other support facilities that encourage Electric Vehicle (EV) and alternative fuel vehicle use, carpooling and car sharing services.
10. Install EV chargers in all homes within the Low Density Residential land use designation areas, some homes in the Medium Density Residential, Active Adult and Village Center land use designation areas, as well as within the parking lots of commercial projects in the Village Centers (see Fanita Ranch EIR Appendix H, Greenhouse Gas Analysis).
11. Develop a Transportation Demand Management plan that considers community programs and includes ride-sharing, alternative modes and other strategies to reduce single occupancy vehicle use.
12. Encourage local food source to reduce vehicle trips and vehicle miles traveled associated with food distribution, and education programs for homeowners to grow sustainable and edible vegetation.

13. Support home-based businesses and telecommuting by allowing home-based businesses, live-work units, business support services and shared workspace in Village Centers.
14. Promote community education and lifelong learning opportunities through the provision of a Farm, edible landscaping and AgMeander trails, a K-8 school site and interpretive elements throughout the community, and a variety of educational programs that inform and promote a sustainable and healthy lifestyle, honor the land's agrarian legacy, and support community participation.

### **9.5.3 Energy, Atmosphere and Building System Performance**

#### **A. Energy, Atmosphere and Building System Objectives**

1. Implement the required Green Building standards set forth in the California Building Energy Efficiency Standards (Title 24, Part 6) and CALGreen (Title 24, Part 11).
2. Consider passive building design and optimize building energy performance to help reduce energy consumption.
3. Reduce heat island effect through the use of cool roof or similar technologies and tree and shrub planting.
4. Incorporate green or renewable energy sources.

#### **B. Energy, Atmosphere and Building System Features**

1. Incorporate building orientation and fenestration that take advantage of sunlight, shade and prevailing winds to maximize passive solar energy, natural ventilation and take advantage of daylighting during daytime hours.
2. Incorporate overhangs or other shading device to limit solar heat gain.
3. Utilize EnergyStar appliances, energy efficient lighting fixtures, tankless water heaters, increased wall, window and duct insulation and minimizing air leaks to the building envelope by utilizing air barriers on exterior walls shall be utilized in all residential and commercial construction.
4. Utilize efficient and properly sized HVAC systems.
5. Implement pollutant control measures such as duct covering and mechanical equipment protection during construction and using low-VOC emitting building materials for flooring, carpet, adhesives, caulks, paints, insulations, etc. to protect air quality.



6. Prohibit wood-burning stoves, fire pits and fireplaces in all residential land use designation areas.
7. Permit a total of six (6) natural gas fire pits or fireplaces within community areas of the Villages.
8. Encourage shared parking between uses to reduce pavement areas.
9. Encourage the use of light-colored, semi-reflective or cool roof technology for roofing, parking lots and other hardscape applications.
10. Plant shade trees in parking lots, along the streets, walkways and other paved areas.
11. Install rooftop solar power (PV) to offset the demand on the electric grid.
12. Implement a potential solar farm for generating sustainable power within the community.
13. Utilize LED or other high efficiency light bulbs for outdoor lighting.

#### **9.5.4 Water Conservation and Water Quality**

##### **A. Water Conservation and Water Quality Objectives**

1. Promote best management practices (BMPs) for water conservation as outlined in the Padre Dam Municipal Water District (PDMWD) Master Plan to minimize the use of imported water.
2. Reduce indoor water use by installing water efficient plumbing fixtures/fittings and appliances, including high efficiency water heaters, water efficient dishwashers, insulated hot water pipes and separated cold and hot water piping.
3. Reduce outdoor water use by using water efficient landscaping, limiting conventional turf to  $\leq 25\%$  of required landscape areas and using efficient irrigation systems and other sustainable landscape practices, including weather-based irrigation control systems or moisture sensors. Landscape and irrigation will comply with the applicable provisions of the California Code of Regulations, Title 23, Division 2, Chapter 2.7, Model Water Efficient Landscape Ordinance (MWELO) or Guidelines for Implementation of the City of Santee Water Efficient Landscape Ordinance, whichever is more stringent.
4. Protect water quality by implementing feasible Low Impact Development (LID) and BMPs to maintain the current level of water runoff (discharge) leaving the site close to pre-development levels.

5. Design water quality features to minimize stormwater and urban runoff impacts generated from the development, consistent with state and regional stormwater quality requirements.

### **B. Water Conservation and Water Quality Features**

1. Utilize Advanced Treated Water from the East County Advanced Water Purification Program.
2. Use feasible LID techniques and BMPs consistent with the City of Santee BMP Design Manual.
3. Implement Green Streets along portions of Fanita Parkway, Cuyamaca Street, Carlton Hills Boulevard and Magnolia Avenue that include bio-filtration features to slow, filter and cleanse stormwater runoff from impervious surfaces.
4. Use inlet filters and rain barrels for single family homes, and appropriately sized detention basins such that there is no impact on downstream drainage facilities, both natural and manmade.
5. Install low flow water fixtures, dual flush toilets, grey water systems (where appropriate) and other water efficient plumbing fixtures/fittings and appliances.
6. Install native, non-invasive and drought tolerant plant species, limitations on turf and landscaping techniques that reduce water demand and promote carbon sequestration.
7. Implement hydrozoning to allow for efficient application of water and optimum plant growth while minimizing evaporation and runoff.
8. Utilize high-efficiency/smart irrigation controllers.
9. Utilize green waste mulch and soil amendments to retain soil moisture.
10. Promote community programs that educate residents and businesses on water conservation.

## **9.5.5 Material Conservation, Recycling and Waste Reduction**

### **A. Material Conservation, Recycling and Waste Reduction Objectives**

1. Encourage simple building designs and efficient framing practices to reduce construction material use and waste.
2. Encourage recycling and diverting of construction waste from landfills.

3. Encourage the use of sustainable building materials.
4. Apply BMPs for waste management and recycling strategies as appropriate.

# Chapter 10: Implementation

## 10.1 Introduction

This chapter identifies required public improvements and a phasing and financing plan for those improvements. Operation and maintenance responsibilities of various parks and recreation facilities, public open space areas, public roadways, drainage facilities and other public infrastructure are also provided. The cost revenue fiscal assessment is provided under separate cover. The Development Agreement will be negotiated and considered for approval in conjunction with the Fanita Ranch Specific Plan, Tentative Map and other project entitlements.

## 10.2 Required Public Improvements

Required public improvements for Fanita Ranch include the following:

- A. **Public Roadways** - Fanita Ranch includes new backbone roadways. A description of roadway improvements, including cross sections, is provided in *Chapter 4: Mobility*. Connection of the on-site circulation system to the off-site circulation system will be achieved by the northward extensions of Fanita Parkway, Cuyamaca Street and Magnolia Avenue.
- B. **Public Infrastructure** - *Chapter 8: Grading, Utilities & Services*, describes infrastructure improvements, other than roads, that will be installed as part of the Fanita Ranch Project. These include water, sewer and storm drain improvements.
- C. **Fire Station** - *Chapter 3: Land Use & Development Regulations* require the provision of a new City Fire Station site within Fanita Commons. The Specific Plan also requires the establishment of fuel modification zones and other fire improvements. These improvements are outlined in the Fanita Ranch Fire Protection Plan and are briefly described in *Chapter 8: Grading, Utilities & Services*.



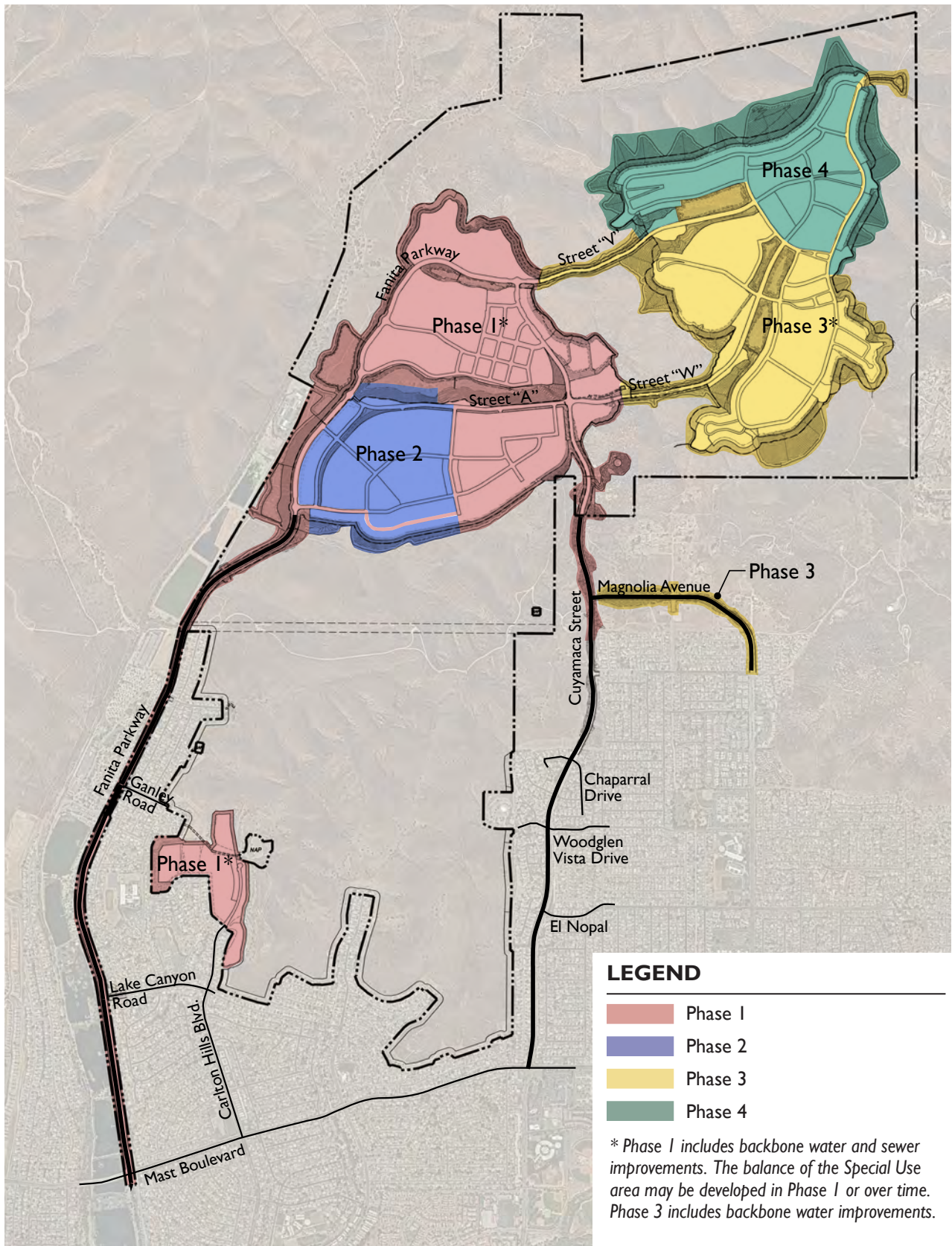
- D. **Parks & Trails** - *Chapter 7: Parks, Recreation & Open Space* describes the parks and trails improvements which include a public community park and a public neighborhood park in Fanita Commons, and private neighborhood parks, mini-parks and trails through the open space areas in the remaining portions of the community.
- E. **School Site** - *Chapter 3: Land Use & Development Regulations* applies a school overlay on a site planned to accommodate a K-8 school (S-1 planning area on *Exhibit 3.2, Site Utilization Plan*). The underlying land use for the school overlay site is MDR. It is the project's goal to implement the K-8 school in concert with Santee School District. Should the school site not be acquired for a public or private school use within two years of approval of the final map for the phase in which the site is located, the site may be developed consistent with the underlying MDR land use designation and the maximum total number of dwelling units in the Specific Plan Area shall be 3,008 units. The additional 59 MDR units have been analyzed in the EIR, and additional units may be transferred from other planning areas within Fanita Ranch to this planning area to achieve the required MDR density, subject to the dwelling unit transfer requirements set forth in *Section 10.7.1: Administrative Amendments (Minor Modifications)*.

### 10.3 Phasing

The objective of the Conceptual Phasing Plan (see *Exhibit 10.1: Conceptual Phasing Plan*) is to coordinate the provision of public facilities and services with the anticipated sequence and pattern of development. The Conceptual Phasing Plan is divided into four phases as described below. The Phasing Plan is conceptual in nature and may change over the development lifetime of Fanita Ranch in response to changing market conditions or other unforeseen conditions. The phasing of development and implementation of public facilities may be modified, provided that the required public improvements are provided at the time of need. Amendments to the Conceptual Phasing Plan are considered administrative in nature. The Development Agreement will outline the nature and timing of certain public infrastructure and facility improvements.

- Phase 1: Fanita Commons and the easterly portion of Orchard Village, off-site and on-site partial improvements to Fanita Parkway and Cuyamaca Street, sewer infrastructure through the Phase 2 area and water infrastructure in the Special Use area
- Phase 2: Westerly portion of Orchard Village
- Phase 3: Connections to the southerly half of Vineyard Village, water infrastructure through the Phase 4 area and off-site partial improvements to Magnolia Avenue
- Phase 4: Northerly half of Vineyard Village

These phases are conceptual and non-sequential and may occur concurrently. Phases may overlap or vary depending upon market conditions. They may also be broken down into smaller sub-phases. Each phase will likely take two to four years to complete. Construction is anticipated to begin in summer



Conceptual phasing shown only; subject to future phasing refinements.

⊕ not to scale

**Exhibit 10.1: Conceptual Phasing Plan**

2021 with a build-out of approximately 10 to 15 years. The Special Use area and adjacent mini-park are not tied to the development phasing described above and may be developed anytime during project build-out; however, water infrastructure within the Special Use area will be constructed during Phase 1.

## **10.4 Public Improvements Financing**

The size and scope of Fanita Ranch, as well as its anticipated 10 to 15 year build-out, suggest that a variety of financing measures may be required to finance the construction of required public improvements.

Various alternative financing programs are identified below. They include – but are not limited to – Special Assessment Districts, the Mello-Roos Community Facilities Act, reimbursement agreements, per unit hook-up fees, turnkey financing by individual project builders, State and Federal grants and loans, and various types of impact fees and exactions. The following list of financing programs is not exhaustive and other financing programs or vehicles may also be used to fund public improvements.

### **10.4.1 Special Assessment Districts**

Assessment Districts formed under the Improvement Act of 1911 (Streets and Highway Code Section 5000 et seq.) and the Municipal Improvement Act of 1913 (Street and Highway Code Section 1000 et seq.) are authorized to pay for public infrastructure improvements such as streets, sewers, storm drains, water improvements, streetlights, flood control systems, parks and curbs and gutters. The method of apportionment dictates that direct and special benefit must be received by the properties assessed for the improvements authorized and constructed or acquired. Generally, bonds are issued to finance the improvements through the Improvement Bond Act of 1915 (Streets and Highway Code Section 8500 et seq.). An assessment district is subject to the noticing and majority protest balloting provisions of Proposition 218, with ballots weighted according to financial obligation.

Landscaping and Lighting Districts formed under the Landscape Lighting Act of 1972 (Streets and Highway Code Section 22500 et seq.) can finance the cost of operating, maintaining and servicing landscaping, public lighting, appurtenant facilities including but not limited to curbs, gutters, walls, sidewalks or paving, or water, irrigation, drainage or electrical facilities, park and recreational improvements. The method of apportionment for Assessment Districts applies to Landscaping and Lighting Districts and a direct and special benefit must be received by the properties assessed for the maintenance of the improvement authorized. The noticing and majority protest balloting process that applies to Assessment Districts pursuant to the provisions of Proposition 218 applies to Landscaping and Lighting districts.



### **10.4.2 Mello-Roos Community Facilities Act of 1982**

Community Facilities Districts formed under the Mello-Roos Community Facilities Act of 1982 (Government Code Section 53311 et seq.) can finance facilities with a useful life of five years or longer, such as street and roadway improvements, water systems, sewers, storm drains and flood control improvements, community improvements and facilities, and finance services relating to law enforcement, fire, parks, parkways and open space maintenance, flood and storm protection. The Community Facilities District is authorized to issue bonds to finance the acquisition or construction of facilities and to levy a special tax to repay the bonds or finance the services authorized. The method of apportionment must be reasonable but cannot be based directly on the value of property. A community facilities district is subject to the voter/Landowner/Master Developer provisions of the Act of a Landowner/Master Developer election if there are less than twelve registered voters in the district.

Benefit Assessment Districts formed under the Benefit Assessment Act of 1982 (Government Code Section 54710 et seq.) can finance the maintenance and operation of drainage services, flood control services, street lighting and street, road or highway maintenance. The method of apportionment requires that for flood control services, the basis of the assessment be based on proportionate storm water runoff; and for street lights, the assessment be a uniform rate. The noticing and majority protest balloting process that applies to Assessment Districts pursuant to the provisions of Proposition 218 applies to Benefit Assessment Districts.

### **10.4.3 Business Improvement Districts**

Business Improvement Districts formed under either the Parking and Business Improvement Law of 1989 (Street and Highway Code Section 36500 et seq.) of the Property and Business Improvement District Law of 1994 (Street and Highways Code Section 36600 et seq.) can acquire, construct, install or maintain parking facilities, benches, trash receptacles, street lighting, decorations, parks and fountains. It can provide services such as promotion of public events, furnishing of music in any public place, promotion of tourism, activities, which benefit businesses in the district. Only businesses in a district can be assessed on the basis of estimated benefit. The noticing and majority protest balloting process required by Proposition 218 is enhanced under the 1944 Act to include both mailing of individual notices to all business owners as well as published public notices.

### **10.4.4 Community Service Districts**

Community Service Districts and County Service Area formed under the Community Services District Law (Government Code Section 16000 et seq.) or the County Service Area Law (Government Code Section 25210.1 et seq.) can provide extended services including but not limited to water service, street lighting, refuse and garbage collection, and road maintenance. The method of apportionment can be on a uniform or benefit basis. The formation of these types of districts include approval of a local agency formation commission and an election process.



## 10.5 Operation and Maintenance

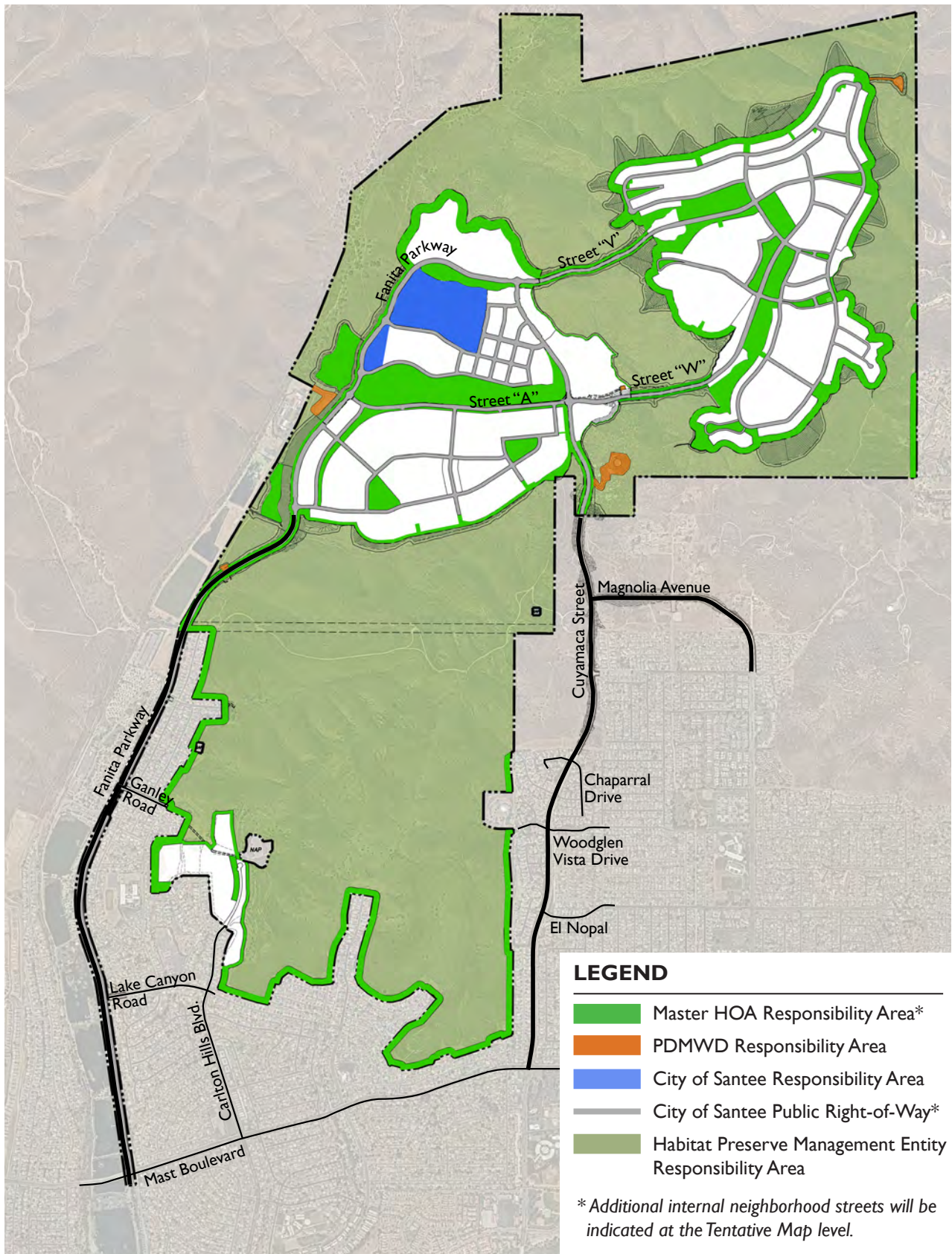
Maintenance responsibilities for public and common area improvements may be addressed in a Development Agreement and/or other agreement(s) between the Landowner/Master Developer and the City of Santee. Those responsibilities will, to the extent they may be different, take precedence over the concepts described in this Specific Plan.

It is anticipated that the Landowner/Master Developer will be required to dedicate Conservation Easements over the Santee MSCP Subarea Plan areas and transfer ownership to an entity consistent with the MSCP Plan as applicable. It is also assumed that the accepting entity will become responsible for managing, monitoring and maintaining the property and assuring its sustainable preservation.

*Exhibit 10.2: Operation and Maintenance Responsibility Areas* shows the distribution of anticipated responsibility areas for the HOA, City of Santee and the Habitat Preserve entity.

Generally, it is also anticipated that:

- A. Private parks, common open space areas and private roads will be maintained by a Homeowners Association(s) (HOA), Property Owners Association(s) and/or a Landscape Maintenance District (LMD) as mutually agreed between the Landowner/Master Developer and City of Santee.
- B. Maintenance of Fuel Modification Zones within private homeowner lots will be the responsibility of the homeowner. Maintenance of Fuel Modification Zones outside the private homeowner lot boundaries will be the responsibility of the HOA or Habitat Preserve management entity, as identified in the Fanita Ranch FPP.
- C. The Community Park and Neighborhood Park 8 (refer to *Exhibit 3.2, Site Utilization Plan*) will be dedicated to the City of the Santee. A mechanism and schedule for constructing and maintaining the parks shall be provided in the Development Agreement or other agreement(s) between the Landowner/Master Developer and City.
- D. Water and sewer facilities will be dedicated to the Padre Dam Municipal Water District (PDMWD). PDMWD will be responsible for the operation and maintenance of these areas, including water storage sites and related facilities.



 not to scale **Exhibit 10.2: Operation & Maintenance Responsibility Areas**

## **10.6 Administration and Implementation**

The purpose of this section of the Specific Plan is to define certain implementation and administrative procedures to provide clear instructions and notice to property owners and developers within Fanita Ranch regarding permit and plan approvals. The general intent of these regulations is to use the prevailing City of Santee procedure(s) to enforce the provisions of the zoning and subdivision codes unless otherwise described herein. The City of Santee Development Services Department shall enforce the site development standards set forth herein, in accordance with the State of California Government Code, Subdivision Map Act, the City of Santee General Plan and the City of Santee Municipal Code (SMC). The development procedures, regulations, standards and specifications contained in this adopted Specific Plan shall supersede the relevant provisions of the SMC and development regulations, as they currently exist or may be amended in the future.

### **10.6.1 Severability**

If any section, subsection, sentence, clause, phrase or portion of this Specific Plan, or any future amendments or additions hereto, is for any reason held to be invalid or unconstitutional by the decision of any court of competent jurisdiction, such decision shall not affect the validity of the remaining portions of this Specific Plan, or any future amendments or additions hereto. The City hereby declares that it would have adopted these requirements and each sentence, subsection, clause, phrase, or portion or any future amendments or additions thereto, irrespective of the fact that any one or more sections, subsections, clauses, phrases, portions or any future amendments or additions thereto may be declared invalid or unconstitutional.

### **10.6.2 Conflicts and Clarifications**

If ambiguity exists with respect to matters of height, setback requirements, area requirements, or land use designation or planning area boundaries as set forth herein, it shall be the duty of the Development Services Director to ascertain all pertinent facts and make a determination based upon the proposed uses consistency with the intent of the Specific Plan.

To ensure that the Specific Plan will permit all similar uses in each land use designation, the Development Services Director, upon his or her own initiative or upon written request, shall determine whether a use not specifically listed as a permitted or temporary use in any land use designation shall be deemed a permitted use in one or more land use designations on the basis of similarity to uses specifically listed.

Application for determination of similar uses shall be made in writing to the Director of Development Services Department (Development Services Director) and shall include a detailed description of the proposed use and such other information as may be required by the Development Services Director to facilitate the determination. The Development Services Director, or designee, shall compare the

proposed use characteristics with the General Plan and Specific Plan goals and objectives as well as the purposes of each of the land use designations, and may determine if the proposed use should be a permitted use in any of the land use designations and shall document his or her findings. The Development Services Director shall base his or her decision upon meeting the following findings:

- A. The use in question has similar functional characteristics as, and is compatible with, other permitted or temporary uses in the same land use designation and does not exceed the maximum density or square footage of the land use designation in which it is proposed.
- B. The use in question meets the purpose and intent of the land use designation in which it is proposed.
- C. The use in question meets and conforms to the applicable goals and objectives of the Santee General Plan.

### **10.6.3 Substantial Conformance**

The Development Services Director may determine a project or use is in substantial conformance to the adopted Specific Plan subject to the findings below. Appeals of the Development Services Director's determination may be made to the City Council in the manner prescribed in Section 13.04.070 of the SMC.

- A. The proposed project or use is substantially consistent with the Santee General Plan, Fanita Ranch Specific Plan and other applicable adopted policies of the City.
- B. The proposed project or use is substantially consistent with the Fanita Ranch Specific Plan and its purpose and intent. Land use, circulation pattern and community design concepts are generally consistent. Statistical variations such as site area calculations shall be 15% or less.
- C. The proposed project or use meets the provisions of the Specific Plan, *Section 3.2: Land Use Designations and Development Regulations* governing the use of land, buildings, structures, building setbacks, building heights and other provisions.
- D. The proposed project or use will not, under circumstances of the particular case, be detrimental to the health, safety or general welfare of persons residing or working in the vicinity, or injurious to property or improvements in the vicinity.
- E. The proposed project or use is substantially consistent with the principles and overall quality of design established for the Fanita Ranch Specific Plan.



## **10.6.4 Subdivisions Standards and Procedures**

Tentative maps, parcel maps and final maps shall be consistent with the development standards set forth by the Fanita Ranch Specific Plan and shall be processed in accordance with the procedures and submittal requirements set forth Title 12, Division I. Subdivision of Land, of the SMC.

## **10.6.5 Development Review**

### **10.6.5.1 Applicability**

An application for Development Review is required for all projects involving the issuance of a building permit for construction or reconstruction of a structure which meets any of the following criteria:

- A. New construction on vacant property.
- B. One or more structural additions or new buildings, with a total floor area of 1,000 square feet or more.
- C. New construction of residential development which is part of a tentative map or tentative parcel map application.
- D. Reconstruction or alteration of existing buildings on sites when the alteration significantly affects the exterior appearance of the building or traffic circulation of the site. Exceptions are maintenance or improvement of landscaping, parking, exterior re-painting or other common building and property maintenance activities.
- E. The conversion of residential or commercial buildings to condominiums.
- F. A Development Review application for an accessory dwelling unit will be processed administratively and not subject to application fees.

The following describes the administrative processes and procedures for reviewing future Development Review applications within Fanita Ranch.

### **10.6.5.2 Preliminary Review Procedures**

The Landowner/Master Developer shall conduct a preliminary Development Review process prior to application submittal to the City for all applications filed during initial build-out of the Fanita Ranch Specific Plan. The preliminary review by the Landowner/Master Developer is for recommendation

purposes only and is intended to add an extra level of review in order to ensure compliance with adopted plans. The preliminary Development Review process includes the following:

- A. The Landowner/Master Developer shall provide project applicants/guest builders with submittal requirements for preliminary Development Review; and
- B. Each application filed with the City shall be accompanied by the Landowner/Master Developer written recommendation for approval, modification or denial of the proposed project.

#### **10.6.5.3 Formal Development Review Procedures**

The Development Review application process, as defined in SMC Title 13, Zoning, Chapter 13.08, Development Review, is designed to ensure that each new project achieves the intent and purpose of the Fanita Ranch Specific Plan. All new development in Fanita Ranch shall be subject to review and approval by the Development Services Director. Development Review is intended to provide sufficient detail in site planning, architectural design and landscape architectural design to enable a specific development project design to be reviewed with respect to compliance with the Fanita Ranch Specific Plan. The Development Review shall include the following:

- A. An application for a Development Review Permit shall be submitted to the Department of Development Services on a form provided by the Department and accompanied by a fee as established by the City.
- B. The application shall be accompanied by a site plan, building elevations, landscape plan and other information as may be required to adequately evaluate the proposed project.
- C. Upon receipt of a Development Review application, the Development Services Director shall review the application based upon the following scope:
  - 1. **Site Adjacencies.** Development Review may be performed on a parcel but may also include a group of buildings or multiple parcels so long as a conceptual design of the entire parcel is provided. Because of the importance of design context and continuity of streetscapes, Development Review submittals shall be required to address relationships to adjacent sites within the Specific Plan Area at a conceptual level. This conceptual planning provides assurance that options for the logical build-out can occur but approval of the Development Review application will not constrain future development proposals. Any projects found not to be in substantial conformance by the Development Services Director may apply for a variance or an amendment to the Specific Plan.

2. **Specific Plan Compliance.** Because of the wide range of appropriate design options within Fanita Ranch, any Development Review submittal that meets the prescriptive standards of *Chapter 3: Land Use & Development Regulations*, as applicable, shall be deemed to be in conformance with the Specific Plan unless substantial evidence is presented to refute the conclusion. Any and all design revisions or conditions applied to a proposed project by the Development Services Director, or other reviewing and approving body, will only be made in order to meet the Specific Plan's design objectives. Any determination made by the appropriate decision making authority that the proposed decision is in conflict with the Specific Plan shall clearly identify the specific objective, policy or design statement that is found to conflict with said proposed design. The fact that a proposed design is not illustrated in the Specific Plan is not evidence of a conflict. The Fanita Ranch Specific Plan utilizes multiple examples of building typologies to convey a sense of design character specifically to avoid a requirement for a specific design. Substantial evidence of conflict requires that the design proposal be inconsistent with the design character conveyed by the multiple examples.
  3. **Landscaping and Outdoor Lighting.** Landscaping and outdoor lighting should reflect the design character, framework and criteria established by *Chapter 5: Landscape Architecture, Community Design & Outdoor Lighting Design Plan*. Except within the riparian and fuel modification zones, additional plant material not specifically identified within the Specific Plan or the Fanita Ranch Fire Protection Plan but are complementary to the established palette and are non-invasive may be deemed to be in conformance with the Specific Plan if approved by the Santee Fire Department.
- D. Applications will be reviewed within 30 days of project submittal to ensure that all of the required information is included.
  - E. Applications shall be reviewed by the Development Services Director for compliance with the Crime Prevention through Environmental Design (CPTED) elements pursuant to the Development Review Criteria stated in SMC Section 13.08.070(I)(7).
  - F. The City shall review projects pursuant to Public Resources Code 21166 for compliance with the Specific Plan and the certified Fanita Ranch EIR.
  - G. Projects inconsistent with the Specific Plan will be required to pursue a Formal Specific Plan Amendment (see *Section 10.7.2* of the Specific Plan) or variance as applicable, which may necessitate additional environmental review. Formal Amendments to the Specific Plan shall be subject to the requirements of the California Environmental Quality Act (CEQA).

- H. Prior to approving a Development Review application, the Development Services Director shall find that:
1. The proposed development is consistent with the Santee General Plan.
  2. The proposed development is consistent with the Fanita Ranch Specific Plan.
  3. The proposed development is consistent with the Fanita Ranch Fire Protection Plan.
  4. The potential environmental impacts of the proposed development have been addressed in the certified EIR for the Fanita Ranch Specific Plan.
- I. Once a Development Review Application has been deemed complete, the Development Services Director shall approve, conditionally approve or deny the application and issue a letter regarding his or her decision within 30 days.
- J. Appeals of the Development Services Director's determination may be made to the City Council in the manner prescribed in Section 13.04.070 of the SMC.

## **10.7 Specific Plan Modifications and Amendments**

Approval of the Fanita Ranch Specific Plan signifies acceptance by the City of Santee of a general framework and specific development standards for Fanita Ranch. It is anticipated that certain modifications to the Specific Plan text and graphics may be necessary through the life of the project. Any modifications to the Specific Plan shall occur in accordance with the amendment process described in this section. Future Administrative Amendments, pursuant to *Section 10.7.1* of this Specific Plan, allow for minor changes to the Specific Plan and may be approved by the Development Services Director. In all cases the amendments must be found to be consistent with the goals and vision of the Fanita Ranch Specific Plan. All other proposed changes are considered Formal Amendments and are required to be reviewed for approval by the City Council.

### **10.7.1 Administrative Amendments (Minor Modifications)**

Upon determination by the Development Services Director, certain minor modifications to the Specific Plan text and/or graphics may be considered ministerial and do not require a public hearing. Such decisions shall be memorialized in a form acceptable to the Department of Development Services and made available for public review upon request. The Development Services Director has the authority to approve Administrative Amendments to the Specific Plan as follows.



A. Transfer of Dwelling Units and Commercial Square Footage: Transfer of dwelling units and commercial square footage is an administrative process conducted by the Development Services Director to ensure that the Fanita Ranch Specific Plan's total maximum numbers of dwelling units and commercial square footage are not exceeded. *Exhibit 3.2: Site Utilization Plan* is intended to provide the general design intent of the Fanita Ranch Specific Plan. The Specific Plan recognizes the need for flexibility in planning to accommodate potential development constraints and future market demands. Notwithstanding the foregoing, if a proposed project is inconsistent with the target density and/or commercial square footage shown for the respective planning area in *Table 3.2: Site Utilization Plan Statistical Summary*, a transfer of dwelling units and/or commercial square footage shall be required. Any reallocation of dwelling units between planning areas in the same land use designation within the same Village is permitted, provided the resulting densities of the granting and receiving planning areas are consistent with the density ranges specified for the land use designation, and the total dwelling unit count for the respective land use designation within the Village is not exceeded. Up to 15% of the total dwelling units for the VC, MDR, LDR, MDR and AA land use designations may be transferred between these land use designations and between the Villages, and any commercial square footage may be transferred between parcels with a "VC" land use designation and "A" overlay areas as well as between the Villages, provided such transfer is consistent with the Specific Plan. The Applicant must demonstrate that the proposed transfer will not impact the major circulation system or infrastructure; the total Average Daily Trips (ADT) does not exceed the total Project Trip Generation<sup>1</sup> identified in the Fanita Ranch Traffic Impact Analysis (see Fanita Ranch EIR Appendix N); and the overall maximum of 2,959 dwelling units and 80,000 square feet of commercial uses in the Specific Plan Area is not exceeded<sup>1</sup>. Any other type of transfer shall require a Formal Amendment. The Development Services Director shall approve or deny the proposed transfer subject to the following findings and conditions:

1. The resulting density of the granting and receiving planning areas shall be consistent with the density ranges specified for the respective land use designations.
2. The planned identity and character of Fanita Ranch is preserved.

---

1. *Chapter 3: Land Use & Development Regulations* applies a school overlay on a site reserved for a K-8 school (S-1 planning area on *Exhibit 3.2: Site Utilization Plan*). The underlying land use for the school overlay site is MDR. If the school site is not acquired for a public or private school use within two years of filing of the final map for the phase in which the site is located, the underlying MDR land use designation may be implemented and the maximum total number of dwelling units in the Specific Plan Area shall be 3,008 units. Residential units may be transferred from VC, MDR, LDR and AA land use designations and planning areas as set forth in (A) above, provided the total ADT for the Specific Plan Area does not exceed the total Project Trip Generation identified in the Fanita Ranch Traffic Impact Analysis under the no-school scenario and the maximum total number of dwelling units in the Specific Plan Area does not exceed 3,008. Units transferred into the S-1 planning area shall comply with the development regulations established for the MDR land use designation. Dwelling unit transfers shall be documented and made publicly available upon request, including updates to Specific Plan *Table 3.1: Land Use Plan Statistical Summary* and *Table 3.2: Site Utilization Plan Statistical Summary*.

3. The project applicant/guest builder has received a letter of recommendations for approval, modification or denial of the dwelling unit and/or commercial square footage transfer from the Landowner/Master Developer.
4. The project applicant/guest builder has provided supporting technical studies, if necessary, to the satisfaction of the Development Services Director that substantiate adequate infrastructure exists to support the requested transfer.
5. Public facilities and infrastructure, including the school and parks, shall be provided based on the final number of units, and the applicant/guest builder shall pay any additional fees resulting from said transfer.
6. The overall maximum intensity of 2,949 residential units and 80,000 square feet of commercial uses in the Specific Plan Area is not exceeded.<sup>1</sup>

Transfers of dwelling units and commercial square footage shall be documented and made publicly available upon request, including updates to Specific Plan *Table 3.1: Land Use Plan Statistical Summary* and *Table 3.2: Site Utilization Plan Statistical Summary*.

- B. Combining or reconfiguring the individual planning areas within a Village Center shown in *Exhibit 3.2: Site Utilization Plan*, provided supporting plans and/or documentation demonstrating adequacy of access and internal neighborhood circulation, if necessary, are provided to the satisfaction of the Development Services Director. Consolidation or reconfiguration of individual planning areas within a Village Center shall be documented and made publicly available upon request, including updates to Specific Plan *Exhibit 3.2: Site Utilization Plan* and *Table 3.2: Site Utilization Plan Statistical Summary*.
- C. Realignment or modification of internal neighborhood streets serving the Specific Plan Area, easement locations and grading adjustments outside the Habitat Preserve boundary, if also approved by the City Engineer or his/her designee.
- D. Minor technical refinements to the boundaries and area calculations of the planning areas listed in Specific Plan *Table 3.2: Site Utilization Plan Statistical Summary* resulting from the approval of a tentative or final map, provided the maximum density of the land use designation and the total land use designation acreage within the Specific Plan Area are not exceeded and the total Habitat Preserve acreage is not reduced. Planning area boundary and acreage adjustments shall be documented and made publicly available upon request, including updates to Specific Plan *Table 3.1: Land Use Plan Statistical Summary* and *Table 3.2: Site Utilization Plan Statistical Summary*.

- E. Minor modifications to the Specific Plan that do not increase the approved densities of the Specific Plan.
- F. Modifications to design criteria such as paving treatments, architectural details and related criteria.
- G. Landscape treatments, fencing, lighting, trails and entry treatments, provided the modifications are in substantial conformance with the purpose and intent of the specified design criteria.

### **10.7.2 Formal Amendments**

All proposed Specific Plan Amendments, which do not meet the criteria for an Administrative Amendment as described on *Section 10.7.1: Administrative Amendments (Minor Modifications)*, shall be deemed to require a Formal Amendment of the Specific Plan. All Formal Amendments shall be reviewed for approval by the City Council at a public hearing and comply with applicable law. It shall be the applicant's/guest builder's responsibility to update any related technical studies and/or provide additional studies when determined necessary by the Development Services Director.

## **10.8 Monitoring and Updates**

In order to ensure continuing compliance with the adopted Fanita Ranch Specific Plan and the provision of certain population based public facilities, the Development Services Director or designee shall at all times maintain an official copy of the Fanita Ranch Specific Plan, including all Administrative Amendments (Minor Modifications) and Formal Amendments thereto, as well as each Development Review approval and/or dwelling unit or commercial square footage transfer as an administrative action, including updates to Specific Plan *Table 3.1: Land Use Plan Statistical Summary* and *Table 3.2: Site Utilization Plan Statistical Summary* (collectively, "Fanita Ranch Specific Plan File"). The current Fanita Ranch Specific Plan File and associated changes, if any, shall be provided to the Development Services Director at the time of each Development Review approval and/or dwelling unit or commercial square footage transfer.

# **Appendix A: Definition of Terms**

The definitions of all terms used in the Fanita Ranch Specific Plan shall have the same meaning as used in the City of Santee General Plan and Santee Municipal Ordinance, unless otherwise specifically defined herein.



<b>Term</b>	<b>Definition</b>
AB 32	The Global Warming Solutions Act of 2006 is a California State Law that addresses Global Warming by establishing a comprehensive program to reduce greenhouse gas emissions from all sources throughout the state.
Accessory Use	Uses of land that are found on the same parcel as the principal use but are subordinate and incidental.
Active Recreation	Outdoor recreational activities, such as organized sports, playground activities, that require extensive facilities.
Active-Adult Neighborhood	An age-targeted or an age-restricted community designed for people aged 55 or older. In order to qualify for the "55 or older" housing exemption, a facility or community must satisfy each of the following requirements: <ul style="list-style-type: none"> <li>• At least 80 percent of the units must have at least one occupant who is 55 years of age or older; and</li> <li>•The facility or community must publish and adhere to policies and procedures that demonstrate the intent to operate as "55 or older" housing; and</li> <li>•The facility or community must comply with HUD's regulatory requirements for age verification of residents.</li> </ul>
Aggregate	A material or structure formed from loosely compacted mass of fragments or particles.
AgMeander	A series of trails and paths that unite nature and agriculture together in an experiential journey through the landscape, connecting agricultural and natural elements in a neighborhood or region.
Agrarian	Relating to cultivated land or the cultivation of land.
Agritourism	Involves any agriculturally based operation or activity that brings visitors to a farm or ranch.
Air Quality	The degree to which the ambient air is pollution-free, assessed by measuring a number of indicators of pollution.
Alternative Compliance	A method for achieving stormwater collection and treatment, emission reduction or risk reduction that is different than the specified standards and how to meet them. Alternative compliance is needed when existing physical conditions exist that prevent standard compliance.
Alternative Fuel Vehicle	A vehicle that runs on a fuel other than traditional petroleum fuels (petrol or diesel fuel).
Animal Husbandry	The science of breeding and caring for farm animals.
Apiaries	Places where a collection of hives of bees are kept.
Aquaponics	Aquaponics refers to any system that combines conventional aquaculture (raising aquatic animals such as snails, fish, crayfish or prawns in tanks) with hydroponics (cultivating plants in water) in a symbiotic environment.

<b>Term</b>	<b>Definition</b>
Best Management Practices (BMPs)	A practice or combination of practices that is determined to be an effective and practicable (including technological, economic, and institutional considerations) means of preventing or reducing the amount of pollutant generated by nonpoint sources to a level compatible with water.
Bike Lane	A division of a road marked off with painted lines, for use by cyclist.
Bike Parking, Long Term	Secure bicycle parking that is protected from the weather, including (1) covered, lockable enclosures with permanently anchored racks for bicycles, (2) lockable bicycle rooms with permanently anchored racks, or (3) lockable, permanently anchored bike lockers, or as otherwise permitted by CALGreen.
Bike Parking, Short Term	Permanently anchored bike racks located within 200 feet of the visitors entrance, readily visible to passers-by, or as otherwise permitted by CALGreen.
Biodiversity	The variety of species in a particular habitat or ecosystem.
Bio-Retention	The process in which contaminants and sedimentation are removed from stormwater runoff.
Building Coverage	The percentage of the lot area that is covered by building area.
CALGreen	Part 11 of the Title 24 Building Standards Code, which is the California Green Building Standards Code.
California Room	An indoor/outdoor room integral to the main residence, with amenities such as fan, television hookups, fireplace, connected by a sliding or folding glass door to the great room or combination of kitchen/family/dining area.
Capital Improvement Program	A short range plan, usually four to ten years, which identifies capital projects and equipment purchases, provides a planning schedule and identifies options for financing the
Carbon Dioxide (CO <sub>2</sub> )	A colorless, odorless gas produced by burning carbon and organic compounds and by respiration.
Carbon Emissions	Often associated with the burning of fossil fuels, like natural gas, crude oil, and coal.
Carbon Footprint	The amount of carbon dioxide and other carbon compounds emitted due to the consumption of fossil fuels by a particular person, group, etc.
Carbon Sequestration	The natural or artificial process by which carbon dioxide is removed from the atmosphere and held in solid or liquid form.
Climate Action Plan (CAP)	A set of strategies intended to guide efforts for climate change mitigation.

<b>Term</b>	<b>Definition</b>
Climate Change	A change in global or regional climate patterns, in particular a change apparent from the mid to late 20th century onwards and attributed largely to the increased levels of atmospheric carbon dioxide produced by the use of fossil fuels.
Cohousing	A group of residential units, which may be attached or detached, that actively participate in the operation of the neighborhood and share common facilities and resources such as childcare, meals, gardens, tools, and other household goods.
Collector Roadway	A low to moderate capacity road which serves to move traffic from local streets to arterial roads.
Commercial Recreation	The provision of recreation-related products or services by private enterprise for a fee, with the long-term intent of being profitable.
Common Open Space	Spaces within the urban setting that are readily and freely accessible to the wider community and which is intended primarily for amenity or recreation purposes.
Community Farm	The growers and consumers providing mutual support and share the risks and benefits of food production.
Community Garden	A piece of land gardened by a group of people, utilizing either individual or shared plots on private or public land.
Complete Street	A street designed and operated to enable safe use and support mobility for multiple user types, including people of all ages and abilities.
Composting	Decay organic material used as a plant fertilizer.
Conditional Use Permit	A zoning exception which allows the property owner use of his land in a way not otherwise permitted within the particular zoning district.
Congregate Care Facilities	Congregate care refers to caring for people in a congregated setting. Residents of congregate care facilities have private apartments but share a common dining room, kitchen facilities, and other amenities.
Conservation	Preservation, protection, or restoration of the natural environment, natural ecosystems, vegetation, and wildlife.
Conservation Easement	A voluntary legal agreement between a landowner and a land trust or government agency that permanently limits uses of the land in order to protect its conservation values.
Cooperative Community	A community where residents actively participate in the operation of the community and share common facilities, resources, and goods. Cohousing and coworking facilities are examples of cooperative communities.

<b>Term</b>	<b>Definition</b>
Coworking	A group of workspaces or offices that share common facilities and resources such as conference rooms, copy machines, kitchen space, and more. Workspace can be rented by individual professionals, small businesses, or small non-profit organizations on an hourly, monthly, or annual basis.
Cultural Resources	Physical evidence or place of past human activity: site, object, landscape, structure or natural feature of significance to a group of people traditionally associated with it.
Dark Sky	Denoting or located in a place where the darkness of the night sky is relatively free of interference from artificial light
Decibel	A unit used to measure the intensity of a sound or the power level of an electrical signal by comparing it with a given level on a logarithmic scale.
Decomposed Granite	Rock of granitic origin that has weathered to the point that it readily fractures into smaller pieces of weak rock.
Degreening Room	A room where the fruit and other agricultural products are processed to remove the inedible portions of the crop.
Department of Housing and Urban Development (HUD)	The principal federal agency responsible for programs concerned with housing needs, fair housing opportunities, and improving and developing U.S. communities.
Design Guidelines	A set of discretionary statements and "development standards" that are a set of threshold requirements which function to preserve and enhance the desired character of existing neighborhoods and improve the aesthetic and functional quality of new development projects.
Development Agreement	An agreement between an individual and a construction company, city or builder to develop a parcel of land for the individual's personal or commercial use.
Development Footprint	The area on the project site that has been impacted by any development activity. Hardscapes, access roads, parking lots, nonbuilding facilities, and building structure are all included in the development footprint.
Director of Development Services	The City of Santee staff member responsible for land use planning, land development engineering, capital improvements, and traffic engineering. This will apply to any subsequent change in the title for the person who supervises these functions.
Drought Tolerant Landscaping	Plants that are low-water consuming.
Dwelling Unit	A structure or the part of a structure that is used as a home, residence, or sleeping place.
Easement	A right to cross or otherwise use someone else's land for a specified purpose.



<b>Term</b>	<b>Definition</b>
Electrical Transmission Easement	A strip of land that an electric utility uses to construct, maintain, or repair a large power line. The easement allows the utility to keep the line clear of vegetation, buildings, and other structures that could interfere with line operation.
Energy Dissipater	Any device designed to protect downstream areas from erosion by reducing the velocity of flow to acceptable limits.
Erosion	The process of eroding or being eroded by wind, water or other natural agents.
Evapotranspiration	The process by which water is transferred from the land to the atmosphere by evaporation from the soil and other surfaces and by transpiration from plants.
Family Day Care, Small	A small family day care home may provide care for up to eight children, without an additional adult present, if specific conditions are met.
Family Day Care, Large	A large family day care home may provide care for up to 14 children, with an assistant present, if specific conditions are met.
Farm Lab	An innovative indoor and outdoor educational experience integrating the Design, Research, Engineering, Art, Math and Science (DREAMS) approach to education.
Farm Stay	Any type of accommodation on a working farm. Some farm stays may be interactive and are family-focused, offering children opportunities to feed animals, collect eggs and learn how a farm functions.
Farm Stand	A stand for display and sale of farm produce and other farm related goods.
Farmers Market	A food market at which local farmers sell fruit and vegetables and often meat, cheese, and bakery products directly to consumers.
Flood Control System	All methods used to reduce or prevent the detrimental effects of flood waters.
Floodlight	A large, powerful light, typically one of several used to illuminate a sports field, a stage, or the exterior of a building.
Food Forest Trail	A walking path lined with several layers of edible plants including tall and understory trees, shrubs, herbs, root crops, vines and groundcover open to community harvest.
Fossil Fuel	A natural fuel such as coal or gas, formed in the geological past from the remains of living organisms.

<b>Term</b>	<b>Definition</b>
Fuel Modification Zone	A strip of land where combustible vegetation has been removed and/or modified and partially or totally replaced with more adequately spaced, drought-tolerant, fire resistant plants in order to provide a reasonable level of protection to structures from wildland fires.
Gateway	A means of access or entry to a place.
General Plan	The citizens blueprint for development and the guide to achieving a vision.
Geologic Resources	Features produced from the physical history of the earth, or processes such as exfoliation, erosion, and sedimentation, glaciation, karst or shoreline processes, seismic, and volcanic activities.
Gravity Sewer System	Large networks of underground pipes that convey blackwater, greywater, and, in many cases, stormwater from individual households to a centralized treatment facility, using gravity (pumps when necessary).
Green Building	The practice of creating structures and using processes that are environmentally responsible and resource-efficient throughout a building's life-cycle from siting to design, construction, operation, maintenance, renovation, and deconstruction.
Green Energy	Energy that comes from natural sources such as sunlight, wind, rain, tides, plants, algae, and geothermal heat. These energy resources are renewable, meaning they are naturally replenished.
Green Street	Pursuant to the EPA, a green street is a stormwater management approach that incorporates vegetation (perennials, shrubs, trees), soil, and engineered systems (e.g., permeable pavements) to slow, filter, and cleanse stormwater runoff from impervious surfaces (e.g., streets, sidewalks). Green streets are designed to capture rainwater at its source, where rain falls; whereas a traditional street is designed to direct stormwater runoff from impervious surfaces into storm sewer systems (gutters, drains, pipes) that discharge directly into surface waters, rivers, and streams.
Greenhouse	A building in which plants are grown that need protection from cold weather.
Greenhouse Gas Emission	Any of the atmospheric gases that contribute to the greenhouse effect by absorbing infrared radiation produced by solar warming of the Earth's surface. They include carbon dioxide (CO <sub>2</sub> ), methane (CH <sub>4</sub> ), nitrous oxide (NO <sub>2</sub> ), and water vapor.

<b>Term</b>	<b>Definition</b>
Greywater	The relatively clean waste water from baths, sinks, washing machines, and other kitchen appliances.
Gross Floor Area	The total floor area inside the building envelope, including external walls, and excluding the roof.
Groundcover	Low-growing, spreading plants that help to stop weeds from growing.
Habitat	The natural home or environment of an animal, plant or other organism.
Habitat Restoration	The practice of renewing and restoring degraded, damaged, or destroyed ecosystems and habitats in the environment by active human intervention and action.
Heat Island Effect	An urban area or metropolitan area that is significantly warmer than its surrounding rural areas due to human activities.
Home Occupation	Any occupation or business use, full- or part-time, conducted within a dwelling or an accessory structure, or both, by a resident of the property.
Homeowners Association (HOA)	An organization of homeowners of a particular subdivision, condominium or planned unit development that provides a common basis for preserving, maintaining, and enhancing homes and property.
Homesteading	A lifestyle of self-sufficiency characterized by individual or communal gardening and agriculture; home preservation of food; farm-to-table food preparation and the sale of local artisanal foods. and may also involve the small scale production of textiles, clothing, and craftwork for household use or for sale.
Horticulture	The art or practice of garden cultivation and management.
Household Demographic	Households and families are basic units of analysis in demography.
Hydrofluorocarbons (HFCs)	Any of a class of partly chlorinated and fluorinated hydrocarbons, used as an alternative to chlorofluorocarbons in foam production, refrigeration, and other processes.
Hydroponics	The method of growing plants without soil, using mineral nutrient solutions in a water solvent.
Hydrozoning	The practice of clustering together plants with similar water requirements in an effort to conserve water.
Incorporated	A region of land that is governed by a local municipal corporation.
Infiltration	Permeation of a liquid into something by filtration.
Infrastructure	The basic physical and organizational structures and facilities needed for the operation of a society or enterprise.

<b>Term</b>	<b>Definition</b>
Irrigation System	A system of supplying land with water by means of artificial canals, ditches, or pipes to promote the growth of food crops or plants.
Landmark	An object or feature of landscape or town that is easily seen and recognized from a distance.
Landscape Maintenance District (LMD)	A special district formed to provide benefitting property owners with the opportunity to pay for enhanced landscaping and appurtenant improvements, maintenance, and services beyond those generally provided by the county.
Landscaping	The process of making a piece of land more attractive by altering the existing design, adding ornamental features, and planting trees and shrubs.
Learning Center	A learning center is typically a designated area that provides students with exciting and interesting experiences to practice, enrich, reteach, and enhance their learning.
Linear Park	A park in an urban or suburban setting that is substantially longer than it is wide.
Live/Work	Property that combines residential living space with commercial or manufacturing space.
Lot Coverage	The amount (expressed in a percentage) of the area of a lot covered by the building footprint, including the garage, porch, patio enclosed on three sides, California room, etc. and excluding eaves.
Low Albedo Pavement	Asphalt pavements that are light in color and/or reflect heat and remain cooler than darker pavements.
Low Impact Development	Systems and practices that use or mimic natural processes that result in the infiltration, evapotranspiration or use of stormwater in order to protect water quality and associated aquatic habitat.
Low Speed Vehicle (LSV)	A legal class of 4-wheel vehicles that have a maximum capable speed typically around 25 mph.
Market Rate	The real price or cost of something decided by a market rather than calculated or fixed.
Master Planned Community	Any community that was carefully planned from its inception and is typically constructed in a previously undeveloped area.
Mello-Roos Community Facilities Act	Allows any county, city, special district, school district or joint powers authority to establish a CFD, which allows for the financing of public services and facilities.
Methane (CH <sub>4</sub> )	A colorless, odorless flammable gas that is the main constituent of natural gas.
Microscopic Organism	An organism that can only be seen with the aid of a microscope and that typically consists of only a single cell.



<b>Term</b>	<b>Definition</b>
Mitigation	The action of reducing the severity, seriousness of something.
Mixed Use	A type of urban development that blends residential, commercial, cultural, institutional, or industrial uses, where those functions are physically and functionally integrated, and that provides pedestrian connections.
Multi-Family Housing	A classification of housing where several separate housing units for residential inhabitants are contained within one building or several buildings within one complex.
Multi-Modal Circulation System	Transportation system that allows for multiple modes of transportation.
Native Landscaping	The use of native plants, including trees, shrubs, groundcover, and grasses which are indigenous to the geographic area of the garden.
Natural Drainage	The natural removal of surface water and sub-surface water from an area.
Natural Hazards	Naturally occurring physical phenomenon caused either by rapid or slow onset events which can be geophysical (earthquakes, landslides, tsunamis, and volcanic activity), hydrological (avalanches and floods), climatological (extreme temperatures, drought and wildfires), meteorological (cyclones, storms/wave surges) or biological (disease epidemics and insect/animal plagues)
Natural Resources	Materials or substances such as minerals, forests, water and fertile land that occur in nature and can be used for economic gain.
Natural Watershed	A small version of a river basin which drains into a larger stream or wetland.
Neighborhood	A district, especially one forming a community within a town or city.
Nitrogen	A colorless, odorless unreactive gas that forms about 78 percent of the earth's atmosphere.
Non-Point Source Pollutants	Pollutants that come from many diffused sources.
Non-Profit	An organization that uses its surplus revenues to further achieve its purpose or mission, rather than distributing its surplus income to the organization's shareholders as profits or dividends.
Non-Slip Surface	A surface designed to prevent sliding, especially being made of sticky material or having a surface with a special texture.
Office Park	An area where a number of office buildings are built together on landscaped grounds.
Off-Street Parking	Parking that is anywhere but on the street.

<b>Term</b>	<b>Definition</b>
On-Farm Composting	Composting is the natural process of 'rotting' or decomposition of organic matter by microorganisms under controlled conditions located on farm land.
On-Street Parking	Parking that is on the street.
Open Space	Any open piece of land that is undeveloped and is accessible to the public.
Organic Material	The large pool of carbon-based compounds found within natural and engineered, terrestrial and aquatic environments.
Parking Management Plan	A plan that addresses parking congestion, traffic congestion, excessive parking facility costs, poor pedestrian environments and the geographic areas to be considered for
Paseo	A plaza or walkway
Passive Recreation	Non-consumptive uses such as wildlife observation, walking, biking, and canoeing.
Pedestrian Circulation	A schematic empirical projection or model of how pedestrians flow through a given area.
Permaculture	The development of agricultural ecosystems intended to be sustainable and self-sufficient.
Permeable Concrete	A special type of concrete with a high porosity used for concrete flatwork applications that allows water from precipitation and other sources to pass directly through, thereby reducing the runoff from a site.
Pesticides	A substance used for destroying insects or other organisms harmful to cultivated plants or to animals.
Phosphorous	A colorless, flammable, toxic gas.
Photo Voltaic Panels (PV)	Panels that allow solar cells to convert energy from the sun into a flow of electrons by the photovoltaic effect.
Photovoltaic Power Station	A large-scale photovoltaic system designed for the supply of merchant power into the electricity grid.
Plant Propagation	Plant propagation is the process of creating new plants from a variety of sources: seeds, cuttings and other plant parts.
Plant Storage	Also called "storage organ" is a part of a plant specifically modified to store energy (e.g. carbohydrates) or water. They are usually found underground (for protection from herbivores) and result from changes to roots, leaves or stems.
Playfield	A playground for outdoor athletics.
Pocket Park	A pocket park (also known as a parkette, mini-park or vest-pocket park) is a small park accessible to the general public. Pocket parks are frequently created on a single vacant building lot or on small, irregular pieces of land.

<b>Term</b>	<b>Definition</b>
Point Source Pollutants	Any single identifiable source of pollution from which pollutants are discharged, such as a pipe, ditch, ship, or factory smokestack.
Post Harvesting Activities	The handling, storage, processing, packaging, and transport of agricultural and horticultural products following a harvest in preparation for sale and distribution. Such activities could include, but are not limited, to drying, degreening (removing the green or other inedible portions of the plant from the edible product), shelling, shucking, and more.
Potable Water Main	A pipe network for distribution of water to the consumers and other usage points.
Preservation	The action of preserving something.
Primary Use	Uses of land that are found on the same parcel as the accessory use but are main use.
Private Open Space	A usable outdoor area that could include balconies, terraces, decks, but does not typically include front yards and areas between a dwelling and the street frontage boundary.
Property Line	The boundary line between two pieces of property.
Property Tax	An ad valorem tax on the value of a property, usually levied on real estate.
Public Art	Any media that has been planned and executed with the intention of being staged in the physical public domain, usually outside and accessible to all.
Public Dedication	An appropriation of land to a public use, made by the owner, and accepted for such use by or on behalf of the public.
Public Improvements	The construction, enlargement, extension or other construction of a facility intended for dedication to an agency, including, but not limited to, a street, curb and gutter, sidewalk, cross gutter, catch basin, drainage improvements, traffic control and street name sign, or other roadway, domestic water supply system, fire hydrant, valve, sanitary sewer main or outfall, lift station, force main, manhole or other appurtenance.
Public Interest Slope	Internal manufactured slopes over 40' in height within Fanita Ranch that are visible from the public rights-of-way identified in Exhibit 8.1: Conceptual Grading Plan of the Fanita Ranch Specific Plan. Public Interest slopes shall be designed using land form grading techniques to recreate and mimic the natural contours and drainages within the surroundings. Maximum cut and fill slope ratios shall be pursuant to Section 8.1: Grading Plan of the Specific Plan.

<b>Term</b>	<b>Definition</b>
Public Park	A public playground, recreation center or area, and other public areas created, established, designated, maintained, provided or set aside by the city, for the purposes of public rest, play, recreation, enjoyment or assembly and all buildings, facilities, and structures located thereon or therein.
Public Realm	The space around, between and within buildings that are publicly accessible, including streets, squares, parks and open spaces.
Pumping Station	Facilities including pumps and equipment for pumping fluids from one place to another.
Quasi-Governmental	A type of corporation in the private sector that is backed by a branch of government that has a public mandate to provide a given service.
Recreational Amenities	Amenities that aid in recreational opportunities such as sports fields, swimming pools, dog parks, etc.
Recycling	The process that converts waste into a reusable material.
Reimbursement Agreement	A contract entered into by a developer and an agency to allow payment to a developer of allowable costs.
Renewable Energy	Energy from a source that is not depleted when used, such as wind or solar power.
Residential	An area of land in which housing predominates.
Retail	An area of land in which commercial uses predominates.
Reverse Osmosis	A process by which a solvent passes through a porous membrane in the direction opposite to that for natural osmosis when subjected to a hydrostatic pressure greater than the osmotic pressure.
Ride-Sharing	An arrangement in which a passenger travels in a private vehicle driven by its owner, for free or for a fee, especially as arranged by means of website or app.
Rights-of-Way	The legal right, established by usage or grant, to pass along a specific route through grounds or property belonging to another.
Riparian Corridor	An area that is the interface between land and a river or stream.
Rooftop Solar Power (PV)	A photovoltaic system that has its electricity-generating solar panels mounted on the rooftop of a residential or commercial building or structure.
Roundabouts	A traffic circle that promotes the flow of traffic.
Runoff	The drainage away of water from the surface of an area of land.
Sales Tax	A tax on sales.



<b>Term</b>	<b>Definition</b>
SB 375	The Sustainable Communities and Climate Protection Act of 2008 is a state law targeting greenhouse gas emissions from passenger vehicles.
Sedimentation	The process of settling or being deposited as a sediment.
Setback	The distance which a building or other structure is setback from a street or road, a river or stream, a shore or floodplain, or any other place which is deemed to need
Single-Family Housing	A stand-alone house, detached residence, or separate house is a free-standing residential building.
Smart Controller	A system that incorporates functions of sensing, actuation, and control in order to describe and analyze a situation, and make decisions based on the available data in a predictive or adaptive manner, thereby performing smart actions.
Smart Growth	Planned economic and community development that attempts to curb urban sprawl and worsening environmental conditions.
Soil Organic Carbon (SOC)	The main component of soil organic matter (SOM) and is one part in the much larger global carbon cycle that involves the cycling of carbon through the soil, vegetation, ocean and the atmosphere.
Solar Array	One or many solar panels that produce energy.
Solar Farm	An installation or area of land in which a large number of solar panels are set up in order to generate electricity.
Solar Water Heating Panels	The conversion of sunlight into heat for water heating using a solar thermal collector.
Special Assessment District	A specific geographic area that the government can assess against real estate parcels for certain public projects.
Specific Plan	A document designed to implement the goals and policies of the General Plan.
Storm Drain	A design to drain excess rain and ground water from impervious surfaces such as paved streets, parking lots, footpaths, sidewalks, and roofs.
Stormwater	Surface water in abnormal quantity resulting from heavy falls of rain or snow.
Streetscape	The natural and built fabric of the street, and the design quality of the street and its visual effect.
Subdivision	An area of land divided into plots for sale.
Subsistence Agriculture	The practice of small-scale agriculture for direct consumption by individuals, families, and small communities, such as home gardens, AgMeander, community gardens, CSAs, community farms, etc.
Suspended Solid	Small solid particles which remain in suspension in water as a colloid or due to the motion of the water.

<b>Term</b>	<b>Definition</b>
Superelevation	The transverse slope obtained by raising the outer edge of the pavement with respect to the inner edge throughout the length of a horizontal curve to counteract the effects of centrifugal force and reduce the tendency of a vehicle to overturn and to skid laterally outwards (banking). Maximum superelevation rates are based on several variables, such as climate, terrain, design speed and pavement friction.
Sustainability	Development that is conducted without the depletion of natural resources.
Swales	Landscaped elements designed to concentrate or remove silt and pollution from surface runoff water.
Take Permit	A permit issued under Section 10 of the United States Endangered Species Act (ESA) to private, non-federal entities undertaking otherwise lawful projects that might result in the take of an endangered or threatened species.
Transit Hub	A place where passengers are exchanged between vehicles or modes of transport
Topography	The arrangement of the natural and artificial physical features of an area.
Traffic Calming Measure	The use of physical design and other measures to improve safety for motorists, pedestrians, and cyclists and to potentially reduce the traffic flow.
Transportation Demand Management Plan (TDM)	A set of strategies that includes transportation demand management to focus on specific needs for integrating TDM into existing activities that are carried out under the transportation planning process.
Unincorporated	A region of land that is not governed by a local municipal corporation.
Urban Sprawl	The uncontrolled expansion of urban areas.
Utilities	Organizations that provide the community with electricity, gas, water, and sewage.
Vesting Tentative Map	The parcel configuration proposed prior to a final or parcel map.
Walkability	A measure of how friendly an area is to walking.
Wastewater	Water that has been used in the home, in a business, or as part of an industrial process.
Water Conservation	The preservation, control, and development of water resources, both surface and groundwater and prevention of pollution.
Water Pressure Zone	The area bounded by both a lower and upper elevation, all of which receives water from a given hydraulic grade line or pressure from a set water surface.

<b>Term</b>	<b>Definition</b>
Water Reservoir	A storage space for water, typically in the form of an enlarged natural or artificial lake, storage pond, or impoundment created using a dam or lock.
Water Velocity	The expression of the displacement that an object or particle undergoes with respect to time.
Wayfinding	All of the ways in which people orient themselves in physical space and navigate from place to place.
Wildlife Corridor	A link of wildlife habitat, generally native vegetation, which joins two or more larger areas of similar wildlife habitat.
Working Farm	A farm whose agricultural land and buildings are in active use for crop production and or the raising of livestock.
Zero Net Energy Standards	A building with zero net energy consumption, meaning the total amount of energy used by the building on an annual basis is roughly equal to the amount of renewable energy created onsite.
Zoning	Divide land into or assign to zones, based on land use.

## Appendix B: Fanita Ranch Street Design

The Fanita Ranch Specific Plan creates a network of streets of varying design capacities tailored to meet the unique concepts of the three Villages. The Specific Plan street designs address safety, aesthetics and functionality as well as site constraints. The Specific Plan street standards are based on the City of Santee Mobility Element (October 2017) and City of Santee Public Works Standards (February 1998). Modifications to the street right-of-way (ROW) widths, curb-to-curb dimensions, sidewalk and median configurations to meet the specific needs of Fanita Ranch are described below.

The Average Daily Trips (ADT) of each proposed Fanita Ranch Specific Plan Street is consistent with the ADT range of the corresponding City of Santee Standard Street. The proposed design speed and geometric design for each Specific Plan street standard meets the City of Santee requirements, with the exception of maximum grade. The justification for increasing maximum grade and other proposed design modifications meets the following conditions:

- A. There are extraordinary or unusual circumstances or conditions applicable to the situation necessitating the need for different street standards for Fanita Ranch, including areas of steep existing topography, minimization of grading quantities, minimization of grading footprint, and minimization of impacts on sensitive resources.
- B. The proposed Specific Plan street standards will not cause substantial drainage, safety, maintenance or other problems.
- C. The proposed Specific Plan street standards will not conflict with existing or future traffic and parking demands or pedestrian or bicycle use.
- D. The proposed Specific Plan street standards will not be detrimental to the public welfare or injurious to the property or improvements within and directly adjacent to the Fanita Ranch site.



*Table B.1: Fanita Ranch Specific Plan Streets*, compares design criteria for each Fanita Ranch Specific Plan Street to the corresponding City of Santee Standard Street.

**Table B.1: Fanita Ranch Specific Plan Streets**

ID	Fanita Ranch Specific Plan Street	City of Santee Street Standard	Modifications
1	Fanita Parkway – 4-Lane Parkway/Major Arterial	4-Lane Parkway / Major Arterial City Standard Option 2	<ul style="list-style-type: none"> <li>• The overall ROW is narrowed from 102' to 97' (89' where median width is reduced).</li> <li>• Improvements within the ROW include a 14' median and a reduced median to curb dimension (from 34' to 31').</li> <li>• The outside travel lanes are reduced from 13' to 12'.</li> <li>• The bike lane buffer is reduced from 4' to 2'.</li> <li>• The sidewalk is eliminated from the east side.</li> <li>• A 10' multi-purpose trail is provided on the west side separated from the travel lane by a 6' wide landscaped parkway to enhance the pedestrian experience and provide an increase sense of pedestrian safety and comfort.</li> <li>• Parkways and median may be super elevated to take up grade from east to west within the limited available right-of-way.</li> <li>• Parkways and medians may have up to a 4:1 slope where shown on plans.</li> <li>• The median width may be reduced from 14' to 6' in the vicinity of wetland and/or biological impacts.</li> <li>• Traffic calming measures include a raised median, narrowed travel lanes and designated on-street bicycle lanes with buffers.</li> </ul>

ID	Fanita Ranch Specific Plan Street	City of Santee Street Standard	Modifications
1A	Fanita Parkway – 3-Lane Parkway	4-Lane Parkway / Major Arterial City Standard Option 2	<ul style="list-style-type: none"> <li>• The overall ROW is narrowed from 102’ to 97’ (89’ where median width is reduced).</li> <li>• Improvements within the ROW include a 14’ median and a reduced median to curb dimension on the west side (from 34’ to 31’) and on the east side (from 34’ to 20’).</li> <li>• The outside travel lane on the west side is reduced from 13’ to 12’ and the bike lane buffer is reduced from 4’ to 2’.</li> <li>• The outside travel lane on the east side is eliminated and the bike lane buffer is reduced from 4’ to 3’.</li> <li>• The sidewalk is eliminated from the east side and a 10’ multi-purpose trail is provided on the west side, separated from the travel lane by a 6’ wide landscaped parkway to enhance the pedestrian experience and provide an increase sense of pedestrian safety and comfort.</li> <li>• Parkways and median may be super elevated to take up grade from east to west within the limited available right-of-way.</li> <li>• Parkways and medians may have up to a 4:1 slope where shown on plans.</li> <li>• The median width may be reduced from 14’ to 6’ in the vicinity of wetland and/or biological impacts.</li> <li>• Traffic calming measures include a raised median, narrowed travel lanes and designated on-street bicycle lanes with buffers.</li> </ul>
2	Cuyamaca Street, Off-Site – 4-Lane Major Arterial	4-Lane Major Arterial City Standard Option 2	No Change

ID	Fanita Ranch Specific Plan Street	City of Santee Street Standard	Modifications
3	Cuyamaca Street, On and Off-Site – 2-Lane Parkway Type 1	2-Lane Parkway with TWLTL	<ul style="list-style-type: none"> <li>• The overall ROW is narrowed from 84’ to 70’ (74’ where turn pocket occurs).</li> <li>• Improvements within the ROW include a raised median at 10’ to 14’ instead of a 12’ painted median and a reduced median to curb dimension (from 26’ to 20’-22’).</li> <li>• The travel lanes are reduced from 13’ to 12’ and the bike lane buffer is increased from 0’ to 3-5’.</li> <li>• Parking is eliminated on both sides; only emergency parking is permitted.</li> <li>• An 8’ multi-purpose trail is provided on the west side, separated from the travel lane by a 6’ wide landscaped parkway to enhance the pedestrian experience and provide an increase sense of pedestrian safety and comfort.</li> <li>• The sidewalk is eliminated on the east side.</li> <li>• A 4.5’ DG trail is provided on the east side, north of water tank 2 to Street “A”/”W” only.</li> <li>• The bike lane and buffer on the west side may be used as an emergency evacuation lane.</li> <li>• Overall pavement width is reduced from 64’ to 52-56’ to reduce heat island effect and to improve water quality.</li> <li>• The maximum grade increased from 10% to 12%.</li> <li>• Lighted sag vertical curves.</li> <li>• Traffic calming measures include roundabouts, raised medians, designated on-street bike lanes and narrowed travel lanes.</li> </ul>



ID	Fanita Ranch Specific Plan Street	City of Santee Street Standard	Modifications
4	Fanita Parkway – 2-Lane Parkway Type II	2-Lane Parkway with TWLTL	<ul style="list-style-type: none"> <li>• The overall ROW is narrowed from 84’ to 77’ (69’ where median width is reduced).</li> <li>• Improvements within the ROW include a raised 14’ median instead of a 12’ painted median and a reduced raised median to curb dimension (from 26’ to 20’-22’’).</li> <li>• The travel lanes are reduced from 13’ to 12’</li> <li>• The bike lane buffer is increased from 0’ to 3’-5’.</li> <li>• Vehicular parking is eliminated on both sides; only emergency parking is permitted.</li> <li>• A 10’ multi-purpose trail is provided on the west side separated from the travel lane by a 6’ wide landscaped parkway to enhance the pedestrian experience and provide an increase sense of pedestrian safety and comfort.</li> <li>• The sidewalk is eliminated on the east side.</li> <li>• The bike lane and buffer on the west side may be used as an emergency evacuation lane.</li> <li>• Parkways and median may be super elevated to take up grade from east to west within the limited available right-of-way.</li> <li>• Parkways and medians may have up to a 4:1 slope where shown on plans.</li> <li>• The median width may be reduced from 14’ to 6’ in the vicinity of wetland and/or biological impacts.</li> <li>• Maximum grade increased from 10% to 12%.</li> <li>• Lighted sag vertical curves.</li> <li>• Traffic calming measures include a community gateway, roundabouts, raised medians, narrowed travel lanes and designated on-street bicycle lanes with buffers.</li> </ul>

ID	Fanita Ranch Specific Plan Street	City of Santee Street Standard	Modifications
5	Fanita Parkway – 2-Lane Parkway Type III	2-Lane Parkway with TWLTL	<ul style="list-style-type: none"> <li>• The overall ROW is narrowed from 84’ to 83’.</li> <li>• Improvements within the ROW include a raised 10’ median instead of a 12’ painted median and a reduced raised median to curb dimension (from 26’ to 22’-25’).</li> <li>• The travel lanes are reduced from 13’ to 12’ and the bike lane buffer is increased on the west side from 0’ to 5’.</li> <li>• Vehicular parking is eliminated on west side; only emergency parking is permitted.</li> <li>• A 10’ multi-purpose trail is on the west side separated from the travel lane by a 6’ wide landscaped parkway to enhance the pedestrian experience and provide an increase sense of pedestrian safety and comfort.</li> <li>• The bike lane and buffer on the west side may be used as an emergency evacuation lane.</li> <li>• Parkways and median may be super elevated to take up grade from east to west within the limited available right-of-way.</li> <li>• Parkways and medians may have up to a 4:1 slope where shown on plans.</li> <li>• Lighted sag vertical curves.</li> <li>• Traffic calming measures include roundabouts, raised medians, raised crosswalks and on-street bicycle lanes with buffers.</li> </ul>

ID	Fanita Ranch Specific Plan Street	City of Santee Street Standard	Modifications
6	Residential Collector Type 1	Residential Collector / 2-Lane Parkway	<ul style="list-style-type: none"> <li>• The overall ROW narrowed from 60' to 59 (69' where left-turn pocket occurs).</li> <li>• Improvements within the ROW include a 10' painted median at intersections only and curb-to-curb dimension increased from 40' to 43'.</li> <li>• Bike lanes are added to both sides.</li> <li>• Parking is eliminated on the south side.</li> <li>• A 6' meandering trail is added to the north side to enhance the pedestrian experience along the linear park.</li> <li>• Maximum grade increased from 10% to 13%.</li> <li>• Lighted sag vertical curves.</li> <li>• Roundabouts and raised intersections are utilized for traffic calming.</li> </ul>
7	Residential Collector Type II	Residential Collector / 2-Lane Parkway	<ul style="list-style-type: none"> <li>• The overall ROW is widened from 60' to 62'.</li> <li>• Improvements within the ROW include a 6' raised median and an increased curb-to-curb dimension (from 40' to 48').</li> <li>• Bike lanes are added to both sides with a 3-5' buffer.</li> <li>• Parking is eliminated on both sides; only emergency parking is permitted.</li> <li>• The sidewalk is eliminated on the north side.</li> <li>• A 6' meandering trail is added to the north side that typically is located outside of the ROW.</li> <li>• The parkway on the south side is increased from 5' to 6.5'.</li> <li>• The bike lane and buffer on the north side may be used as an emergency evacuation lane.</li> <li>• The maximum grade is increased from 10% to 15%.</li> <li>• Lighted sag vertical curves.</li> <li>• Traffic calming measures include a chicane to control downhill speeds, on-street parking, raised medians and designated on-street bicycle lanes with buffers.</li> </ul>

ID	Fanita Ranch Specific Plan Street	City of Santee Street Standard	Modifications
8	Residential Collector Type III	Residential Collector / 2-Lane Parkway	<ul style="list-style-type: none"> <li>• The overall ROW is widened from 60' to 78', 79' and 83' (79' where 6' trail occurs, and 83' where 10' trail occurs instead of 5' sidewalk).</li> <li>• Improvements within the ROW include a 14' raised median and increased curb-to-curb dimension (from 40' to 56').</li> <li>• Bike lanes are added to both sides with 3-5' buffer.</li> <li>• Parking is eliminated on both sides; only emergency parking is permitted.</li> <li>• Parkways are widened from 5' to 6'.</li> <li>• The bike lane and buffer on the north or west side may be used as an emergency evacuation lane.</li> <li>• The maximum grade increased from 10% to 12%.</li> <li>• Lighted sag vertical curves.</li> <li>• Traffic calming measures include roundabouts, intersection pop-outs, raised crosswalks and designated on-street bicycle lanes with buffers.</li> </ul>
9	Magnolia Avenue, Off-Site – Collector Type IV	Collector / 2-Lane Parkway	<ul style="list-style-type: none"> <li>• The overall ROW is widened from 60' to 67'.</li> <li>• Improvements within the ROW include an increase of the curb-to-curb dimension from 40' to 52'.</li> <li>• Bike lane buffers are added to both sides.</li> <li>• Vehicular parking is eliminated on both sides; only emergency parking is permitted.</li> <li>• The maximum grade is increased from 10% to 12%.</li> <li>• Design speed is reduced from 40 mph to 35 mph.</li> <li>• Lighted sag vertical curves.</li> <li>• Traffic calming measures potentially include designated on-street bicycle lanes with buffers, raised pedestrian crossings, intersection neckdowns and flashing radar signs.</li> </ul>



ID	Fanita Ranch Specific Plan Street	City of Santee Street Standard	Modifications
10	Cuyamaca Street – Residential Collector Type V	Residential Collector / 2-Lane Parkway	<ul style="list-style-type: none"> <li>• The overall ROW is widened from 60’ to 75’.</li> <li>• Improvements within the ROW include the addition of a 10’ raised median and curb-to-curb dimension increased from 40’ to 52’.</li> <li>• Bike lanes are added to both sides with 3’-5’ buffer.</li> <li>• Vehicular Parking is eliminated on both sides; only emergency parking is permitted.</li> <li>• An 8’ multi-purpose trail is provided on the west side separated from the travel lane by a 5’ wide landscaped parkway to enhance the pedestrian experience and provide an increase sense of pedestrian safety and comfort.</li> <li>• The maximum grade is increased from 10% to 15%.</li> <li>• Lighted sag vertical curves.</li> <li>• Traffic calming measures include a raised median and designated on-street bicycle lanes with buffers.</li> </ul>
11	Cuyamaca Street - Village Collector	Residential Collector / 2-Lane Parkway	<ul style="list-style-type: none"> <li>• The overall ROW is widened from 60’ to 88’.</li> <li>• Improvements within the ROW include the increased curb-to-curb dimension (from 40’ to 64’).</li> <li>• Diagonal parking provided on both sides.</li> <li>• A 14’ sidewalk/multi-purpose trail on the west side and a 10’ sidewalk on the east side are provided, with tree wells added.</li> <li>• Landscaped parkways are eliminated.</li> <li>• Lighted sag vertical curves.</li> <li>• Traffic calming measures include diagonal parking and on-street bicycle lanes with buffers.</li> </ul>

ID	Fanita Ranch Specific Plan Street	City of Santee Street Standard	Modifications
12	Residential Collector Type VII	Residential Collector / 2-Lane Parkway	<ul style="list-style-type: none"> <li>• The overall ROW is widened from 60' to 62' (63' where 6' trail occurs instead of 5' sidewalk).</li> <li>• Design speed is reduced from 35 mph to 25 mph.</li> <li>• Landscaped parkways are widened from 5' to 6'.</li> <li>• A 6' trail replaces the standard 5' sidewalk where shown on the plan.</li> <li>• The maximum grade increased from 10% to 12%.</li> <li>• Lighted sag vertical curves.</li> </ul>
13	Village Street Type 1	Local Street	<ul style="list-style-type: none"> <li>• The overall ROW is widened from 56' to 80'.</li> <li>• Improvements within the ROW include the addition of a 20' raised median and an increased curb-to-curb dimension (from 36' to 60').</li> <li>• Travel lane plus parking dimension is increased from 18' to 20'.</li> <li>• Landscaped parkways are eliminated.</li> <li>• Sidewalks are widened from 5' to 10' and tree wells added.</li> <li>• Lighted sag vertical curves.</li> <li>• Traffic calming measures include intersection pop-outs and a raised median.</li> </ul>
14	Village Street Type II	Local Street	<ul style="list-style-type: none"> <li>• The overall ROW is widened from 56' to 70'.</li> <li>• Improvements within the ROW include an increased curb-to-curb dimension (from 36' to 50').</li> <li>• Diagonal parking is added to one side.</li> <li>• Landscaped parkways are eliminated.</li> <li>• Sidewalks are widened from 5' to 10'.</li> <li>• Lighted sag vertical curves.</li> <li>• Traffic calming measures include intersection pop-outs and diagonal parking.</li> </ul>

ID	Fanita Ranch Specific Plan Street	City of Santee Street Standard	Modifications
15	Village Street Type III	Local Street	<ul style="list-style-type: none"> <li>• Landscaped parkways are eliminated.</li> <li>• Sidewalks are widened from 5' to 10' and tree wells added.</li> <li>• Lighted sag vertical curves.</li> <li>• Intersection pop-outs are utilized for traffic calming.</li> </ul>
16	Residential Street	Local Street	<ul style="list-style-type: none"> <li>• The overall ROW is widened from 56' to 57'; 58' where 6' trail occurs instead of 5' sidewalk and 62' at school drop-off.</li> <li>• Centerline to curb dimension is increased from 18' to 23' at school drop-off.</li> <li>• Sidewalk width is increased from 5' to 10' where shown on plan as school drop-off.</li> <li>• Parkway width increased from 5' to 5.5'.</li> <li>• The maximum grade is increased from 12% to 15%.</li> <li>• Lighted sag vertical curves.</li> <li>• Intersection pop-outs are utilized for traffic calming.</li> </ul>
17	Split Residential Street, One-Way	Local Street	<ul style="list-style-type: none"> <li>• Additional 3' of paved road width was added to provide for vehicle back-out distance due to one-way configuration. ROW width varies due to each unique median or park configuration.</li> </ul>
18	Carlton Hills Boulevard, Private Street	No City standards for Private Street conditions	<ul style="list-style-type: none"> <li>• The overall ROW is narrowed from 56' to 42' (consisting of a 5' sidewalk, 4' x 8' BMP area and parking on the west side and two 12' travel lanes) by eliminating sidewalk and parking on the east side. Existing ROW easement is 70' and is unchanged.</li> </ul>
19	Private Residential Street	No City standards for Private Residential Street conditions	
20	Private Residential Driveway	No City standards for Private Residential Driveway conditions	

## Street Design Criteria

PROPOSED SECTION – FANITA SPECIFIC PLAN NO.	NAME	FOR FUTURE (Santee Mobility Element Equivalent)	Estimated ADT	DESIGN SPEED MPH	TRAVEL LANES	BIKE LANE	PARKING	MEDIAN WIDTH (FT)	CURB TO CURB (FT)	ROW (FT)	MAX GRADE % (f)	MAX GRADE % THROUGH INTERSECTION	MAX CENL INTERSECTION ANGLE (DEG)	MIN. CENL (g) RADIUS (FT) STD. GROWN/ FULL SUPER	MIN. TRAFFIC INDEX	STOPPING SIGHT DISTANCE
1	FANITA PARKWAY 4 LANE PARKWAY	15,000-40,000 4-Lane Parkway/ Major Arterial City Std. Optn. 2	15,460	50 <sup>(d)</sup>	4-12'	CLASS I & II	EMERGENCY, BOTH SIDES	14 <sup>(h)</sup> RAISED	68', 76'	89', 97'	7	5	10	1400/850	8.5	430'
1a	FANITA PARKWAY 3 LANE PARKWAY	15,000-40,000 4-Lane Parkway/ Major Arterial City Std. Optn. 2	15,130	50 <sup>(d)</sup>	2-12'+ 1-12'	CLASS I & II	EMERGENCY, BOTH SIDES	14 <sup>(h)</sup> RAISED	57', 65'	89'-97'	7	5	10	1400/850	8.5	430'
2	Offsite	15,000-40,000 4-Lane Major Arterial	18,630	50	4-12'	CLASS II	EMERGENCY, BOTH SIDES	14' RAISED	82'	102'	7	5	10	1400/850	8.5	430'
3	On & Offsite	5,000-15,000 2-Lane Parkway w/ TWLTL	13,920	40 <sup>(d)</sup>	2-12'	CLASS II	EMERGENCY, BOTH SIDES	10 <sup>(h)</sup> RAISED	52', 56'	70', 74'	12	5	10	800/550	8.0	300'
4	FANITA PARKWAY 2 LANE PARKWAY TYPE II	5,000-10,000 2-Lane Parkway w/ TWLTL	12,350	40 <sup>(d)</sup>	2-12'	CLASS I & II	EMERGENCY, BOTH SIDES	14 <sup>(h)</sup> RAISED	48', 56'	69', 77'	12	5	10	800/550	8.0	300'
5	FANITA PARKWAY 2 LANE PARKWAY TYPE III	5,000-15,000 2-Lane Parkway w/ TWLTL	9,730	40 <sup>(d)</sup>	2-12'	CLASS I & II	YES ONE SIDE, EMERGENCY ONE SIDE	10' RAISED	57'	83'	10	5	10	800/550	8.0	300'
6	RESIDENTIAL COLLECTOR TYPE I	4,000-10,000 Residential Collector/ 2-Lane Parkway	7,400	35 <sup>(d)</sup>	2-12'	CLASS II	YES ONE SIDE	10' PAINTED	53'	59', 69'	13	5	10	610/400	7.5	250'
7	RESIDENTIAL COLLECTOR TYPE II	4,000-10,000 Residential Collector/ 2-Lane Parkway	6,480	35 <sup>(d)</sup>	2-12'	CLASS II	EMERGENCY, BOTH SIDES	6' RAISED	48'	62'	15	5	10	610/400	7.5	250'
8	RESIDENTIAL COLLECTOR TYPE III	4,000-10,000 Residential Collector/ 2-Lane Parkway	6,480	35 <sup>(d)</sup>	2-12'	CLASS II	EMERGENCY, BOTH SIDES	14' RAISED	56'	78', 88'	12 <sup>(h)</sup>	5	10	610/400	7.5	250'
9	Offsite	4,000-10,000 MAGNOLIA AVENUE Collector/ 2-Lane Parkway	6,310	35 <sup>(d)(h)</sup>	2-13'	CLASS II	YES, BOTH SIDES	12' PAINTED	52'	67'	12	5	10	610/400	7.5	250'
10	RESIDENTIAL COLLECTOR TYPE V	4,000-10,000 Residential Collector/ 2-Lane Parkway	6,180	35 <sup>(d)(h)</sup>	2-12'	CLASS II	EMERGENCY, BOTH SIDES	10' RAISED	52'	75'	15 <sup>(h)</sup>	5	10	610/400	7.5	250'
11	VILLAGE COLLECTOR	4,000-10,000 Residential Collector/ 2-Lane Parkway	6,180	35 <sup>(d)</sup>	2-12.5'	N/A	YES, BOTH SIDES <sup>(i)</sup>	N/A	64'	88'	10	5	10	610/400	7.5	250'
12	RESIDENTIAL COLLECTOR TYPE VII	4,000-10,000 Residential Collector/ 2-Lane Parkway	4,300	25 <sup>(d)</sup>	2-12'	N/A	YES, BOTH SIDES	N/A	40'	62', 63'	12 <sup>(h)</sup>	5	10	200	7.5	160'
13	VILLAGE STREET TYPE I	2,200 (LOCAL)		25	2-12'	N/A	YES, BOTH SIDES	20' RAISED	60'	80'	12	5	10	200	5.0	160'
14	VILLAGE STREET TYPE II	2,200 (LOCAL)		25	1-12.5'+ 1-10'	N/A	YES, BOTH SIDES	N/A	50'	70'	12	5	10	200	5.0	160'
15	VILLAGE STREET TYPE III	2,200 (LOCAL)		25	2-10'	N/A	YES, BOTH SIDES	N/A	36'	56'	12	5	10	200	5.0	160'
16	RESIDENTIAL STREET	2,200 (LOCAL)		25	2-10'	N/A	YES, BOTH SIDES <sup>(i)</sup>	N/A	36'	57', 58', 62'	15 <sup>(h)</sup>	5	10	200	5.0	160'
17	RESIDENTIAL STREET	2,200 (LOCAL)		25	2-10'	N/A	YES, BOTH SIDES <sup>(i)</sup>	N/A	42'	VARIABLES PER PLAN	15 <sup>(h)</sup>	5	10	200	5.0	160'
18	PRIVATE RESIDENTIAL STREET	2,200 (LOCAL)		25	2-12'	N/A	YES, ONE SIDE	N/A	32'	70 <sup>(i)</sup>	12	5	10	200	5.0	160'
19	PRIVATE RESIDENTIAL STREET	1,100 (PRIVATE)		15	2	N/A	SEE PLAN	N/A	VARIABLES PER PLAN	VARIABLES PER PLAN	12	5	10	35	5.0	100'
20	PRIVATE RESIDENTIAL DRIVEWAY	1,100 (PRIVATE)		15	2	N/A	N/A	N/A	VARIABLES PER PLAN	VARIABLES PER PLAN	12	5	10	35	5.0	100'

### NOTES:

- A. THE STREETS WITH A GRADIENT EXCEEDING 12% SHALL BE PCC IN ACCORDANCE WITH PUBLIC WORKS STANDARDS, CITY OF SANTEE.
- B. MEDIAN WIDTH MAY BE REDUCED TO 6' IN THE VICINITY OF WETLAND AND/OR BIOLOGICAL IMPACTS PROVIDED THE REQUIRED TURN POCKETS FUNCTION PROPERLY. PARKWAY AND MEDIAN MAY HAVE UP TO A 4:1 SLOPE WHERE SHOWN ON PLANS.
- C. PARKING MAY BE ELIMINATED ON ONE SIDE WHERE SHOWN ON PLANS.
- D. ENTRY DESIGN SPEED OF A ROUNDABOUT SHALL BE 20 MPH.
- E. CURVE RADII SHOWN ARE PER CALTRANS TABLE 202.2 ASSUMING STANDARD CROWN SECTION. MINIMUM CENTERLINE RADIUS ON SUPER ELEVATED STREETS SHALL BE PER CITY OF SANTEE PUBLIC WORKS STANDARDS TABLE A.
- F. LIGHTED SAG VERTICAL CURVES CALCULATED AS  $L=0.0215AV^2$  MAY BE USED ON ANY STREET PROVIDED THAT STREET LIGHTS ARE INSTALLED TO THE SATISFACTION OF THE DIRECTOR OF DEVELOPMENT SERVICES.
- G. PARKWAY – PARKWAY IS DEFINED BY THE CITY OF SANTEE MOBILITY ELEMENT AS “ROADWAYS REQUIRING UNIQUE DESIGN APPLICATIONS WHERE STANDARD DESIGNS CANNOT BE UTILIZED BECAUSE OF STEEP TERRAIN, RIGHT-OF-WAY CONSTRAINTS, SPECIAL DEVELOPMENT NEEDS AND/OR OTHER SPECIAL CONDITIONS. DUE TO SIGNIFICANT VARIATION ALONG PARKWAY CROSS-SECTIONS, A TYPICAL CROSS-SECTION IS NOT PROVIDED.”
- H. THE FANITA RANCH SPECIFIC PLAN USES CALTRANS STANDARDS FOR HORIZONTAL AND VERTICAL DESIGN GEOMETRY BASED ON THE ASSIGNED DESIGN SPEED FOR EACH ROADWAY TYPE. UNLESS OTHERWISE NOTED STREET DESIGN SHALL CONFORM TO CITY OF SANTEE STANDARDS.
  - I. EXISTING 70' ROADWAY EASEMENT.
- J. THE DESIGN SPEED OF MAGNOLIA AVENUE BETWEEN PRINCESS JOANN ROAD AND CUYAMACA STREET IS 40 MPH; HOWEVER, THE VERTICAL GRADE DOES NOT MEET THE 40 MPH DESIGN SPEED DUE TO CONDITIONS (TERRAIN CONSTRAINTS) FOR WHICH A DESIGN VARIANCE IS PROVIDED ON THE VESTING TENTATIVE MAP.



*Intentionally Blank*